

CABLINE®-VS II

Fully-shielded with mechanical lock, Suitable for high-data-rate transfer (20 Gbps/lane), 5 mm pitch, Horizontal mating type micro-coaxial connector

Product Specifications:

Mating type	Horizontal	
Board Pitch (mm)	0.5	
Wiping Length (mm)	0.54	
Mated size (mm)	Height	1.2 max. with cover
	Width	Formula: 6.85 + (0.5*?p)
	Depth	6.70
Pin Counts	Range	Up to 55
	Available	20, 30, 40

Applicable Cable Size:

Maximum O.D. (mm)	0.5
Micro-Coaxial for Signal (AWG)	45 ohm: #36 or smaller
	50 ohm: #38 or smaller
Twinax (AWG)	#40
Discrete (AWG)	#32 or smaller

Applicable Standards (Reference Only):

USB4 Gen3/Thunderbolt 4 (20 Gbps/lane), PCIe Gen 4 (16 GT/s), USB 3.1 Gen 2 (10 Gbps), eDP HBR 3 (8.1 Gbps)

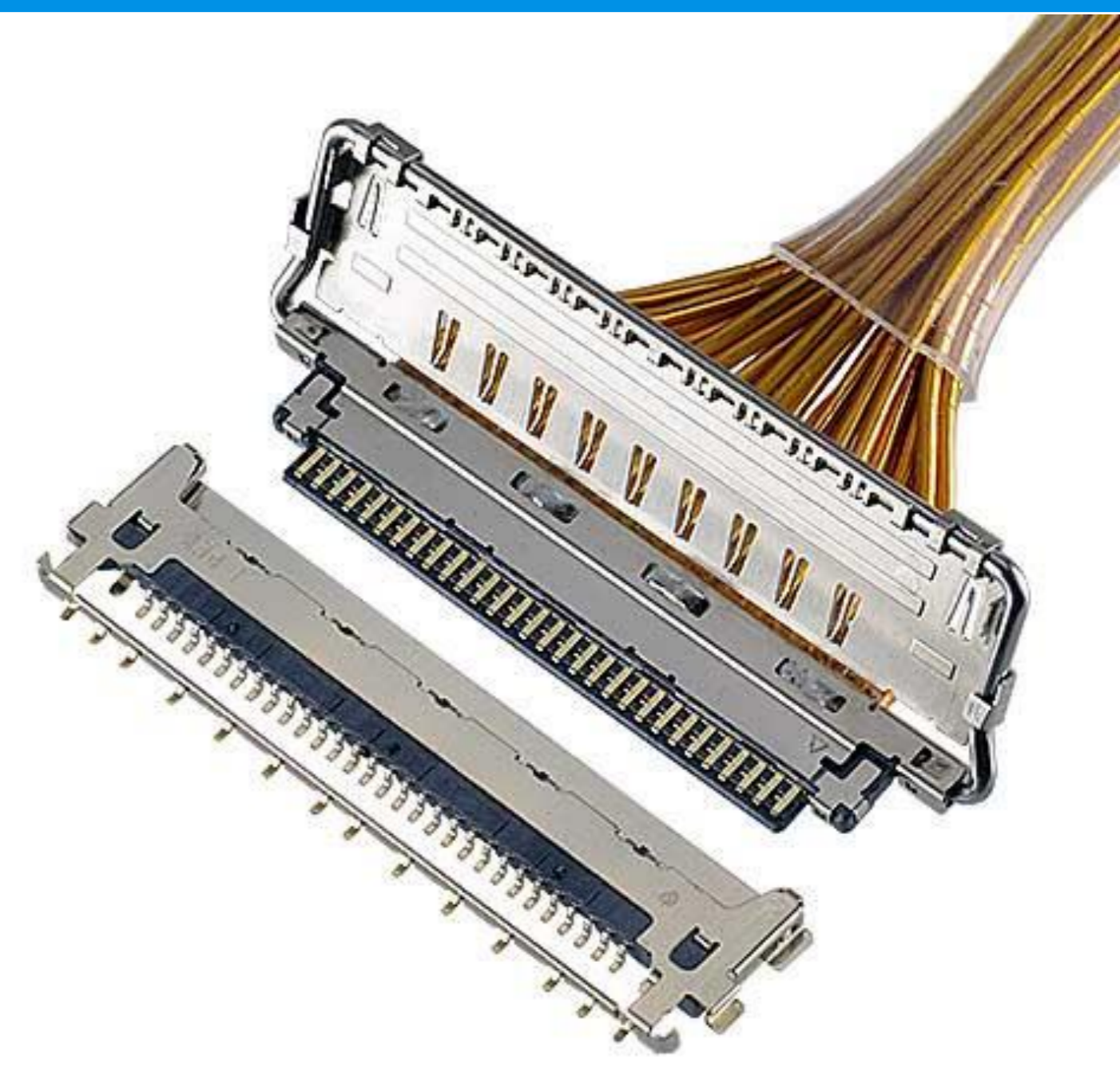

* Please inquire for pin counts not listed or outside of the pin count range.

ZenShield® fully-shielded with multi-point grounds to prevent EMI leakage

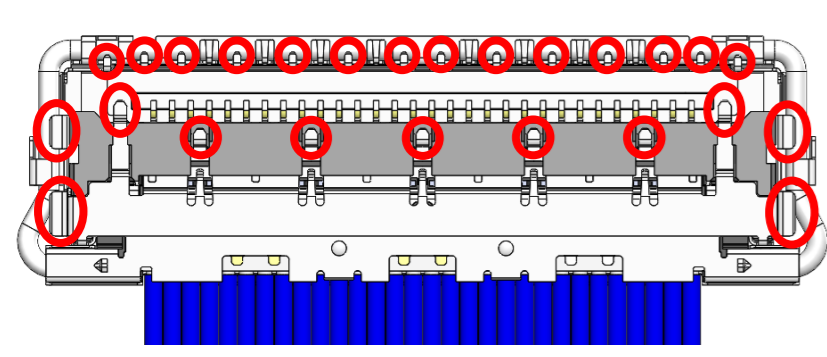

View From Back

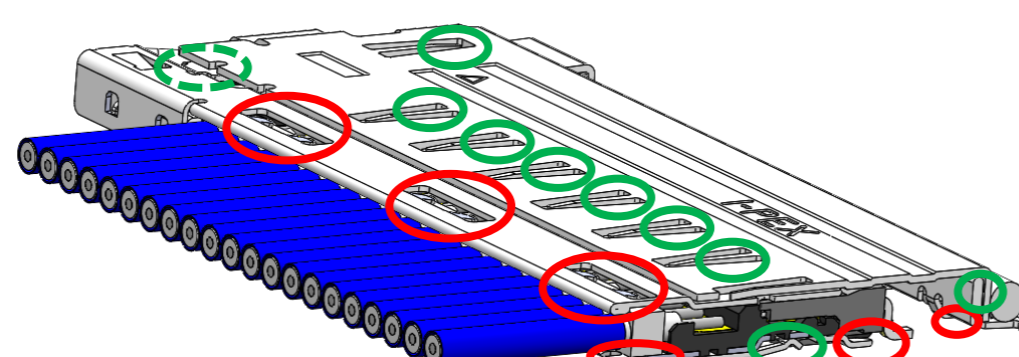

- Soldered contacts
- Mechanical contacts

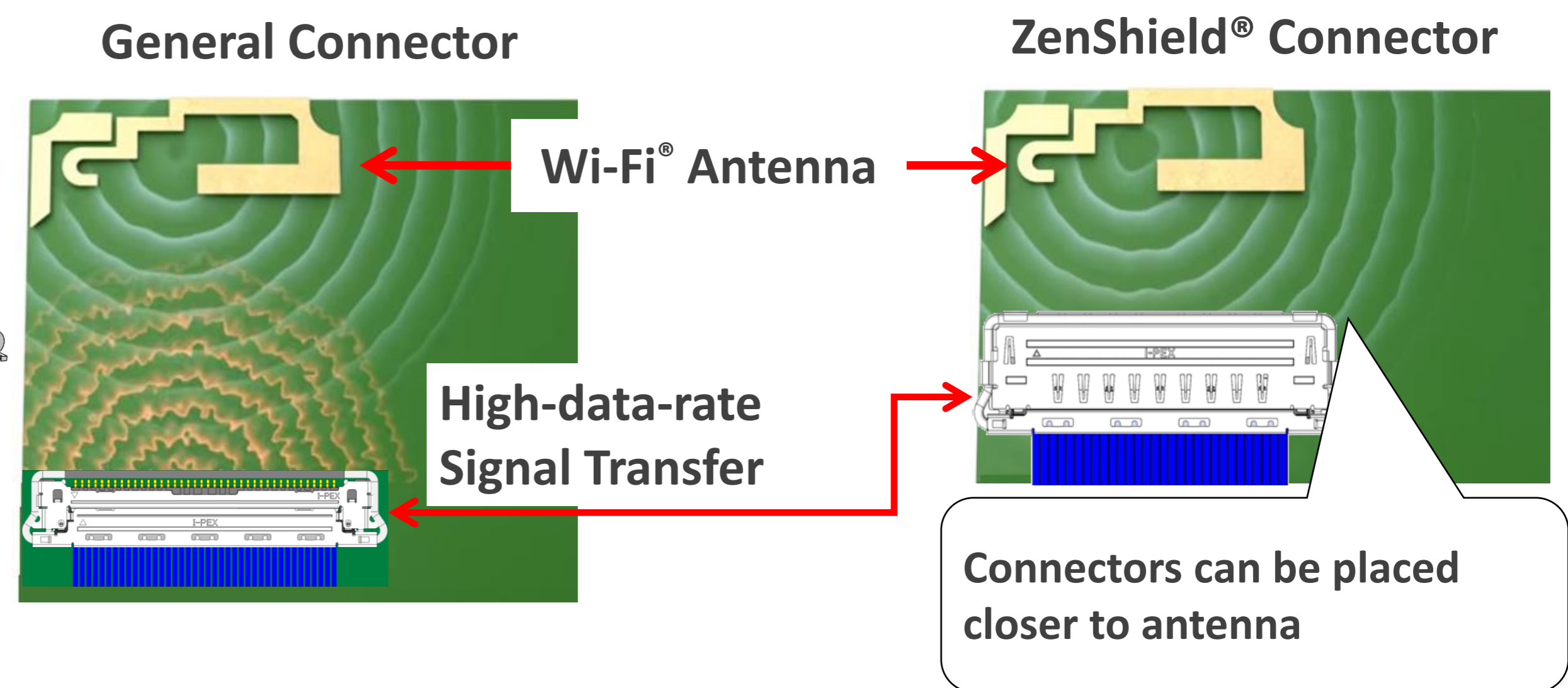

Mechanical locking cover prevents incomplete mating and back-out/unmating

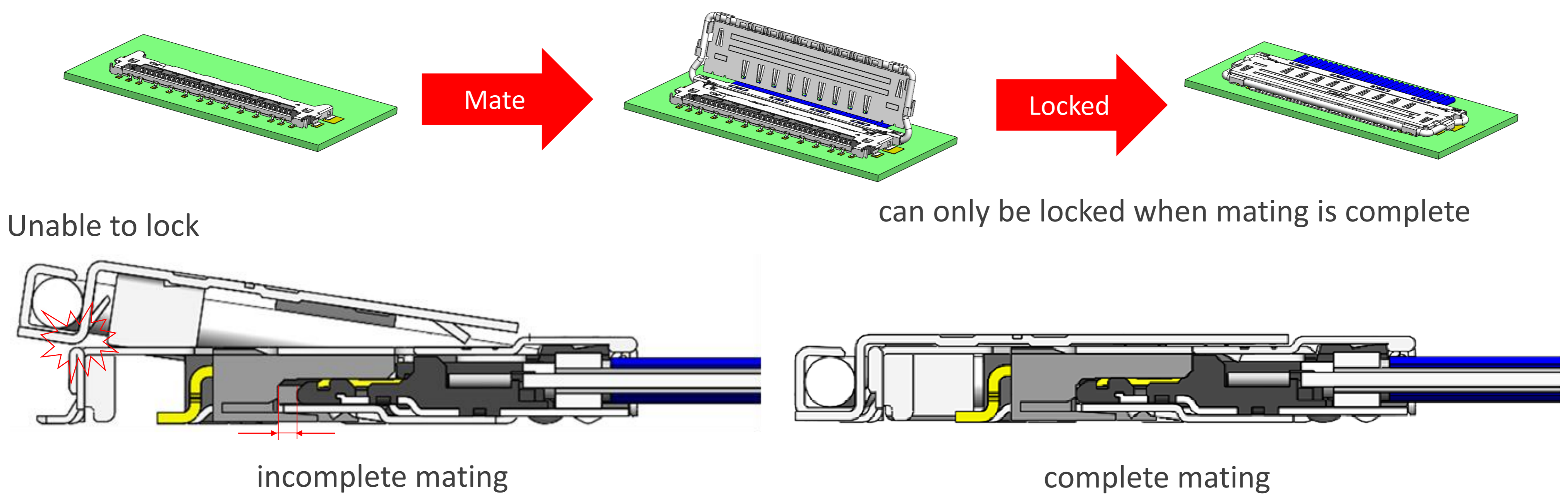

High-data-rate transfer, ideal for USB4 Gen3/Thunderbolt 4 (20 Gbps/lane) applications

USB4 Gen3/Thunderbolt 4 (20 Gbps/lane)

- Eye pattern (Differential)
- Bit rate : 20 Gbps
- Rise time : 30 ps (10-90 %)
- Input voltage : 800 mVp-p

*Please contact I-PEX for more test details.

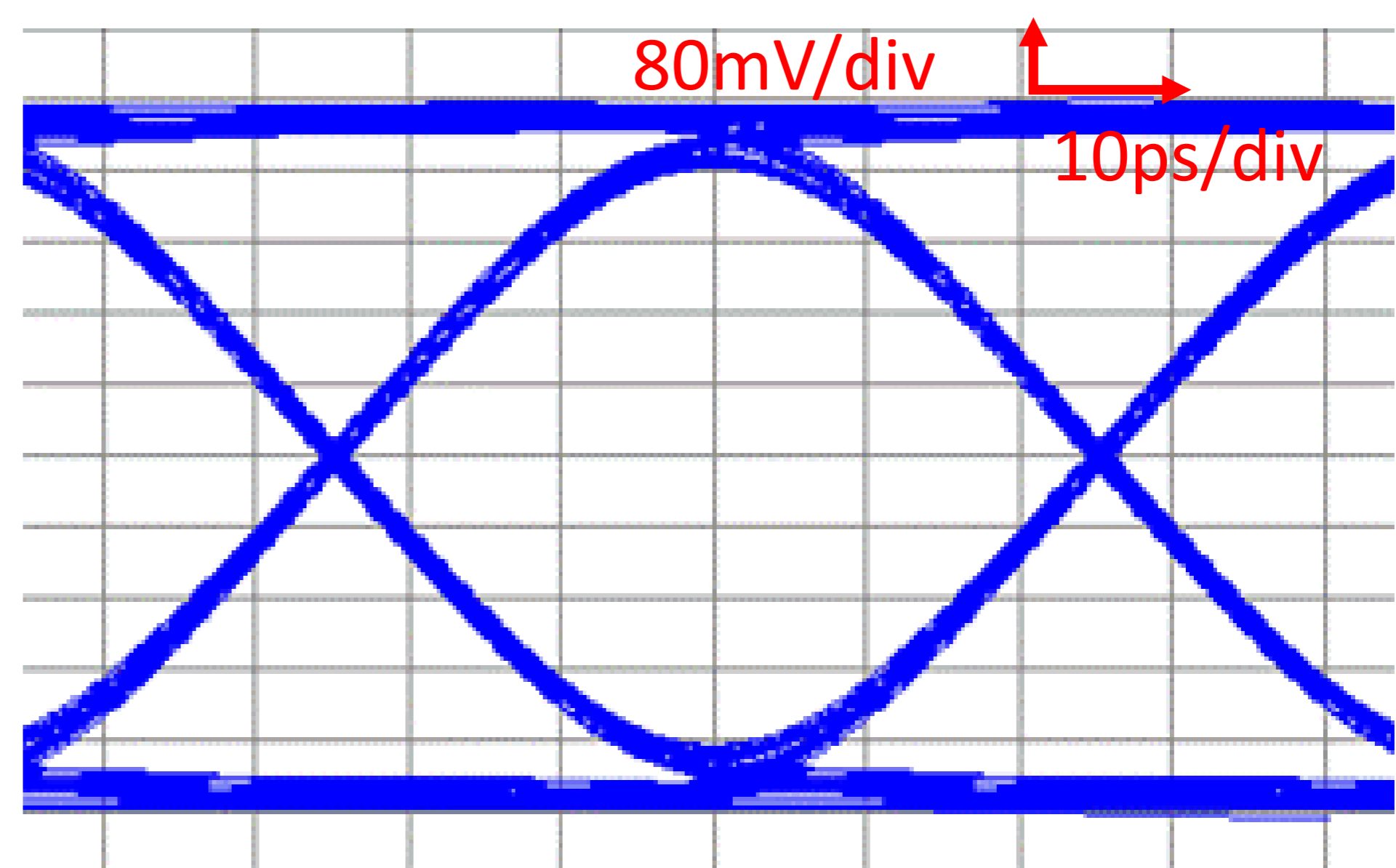

Component Parts Details

Component Parts

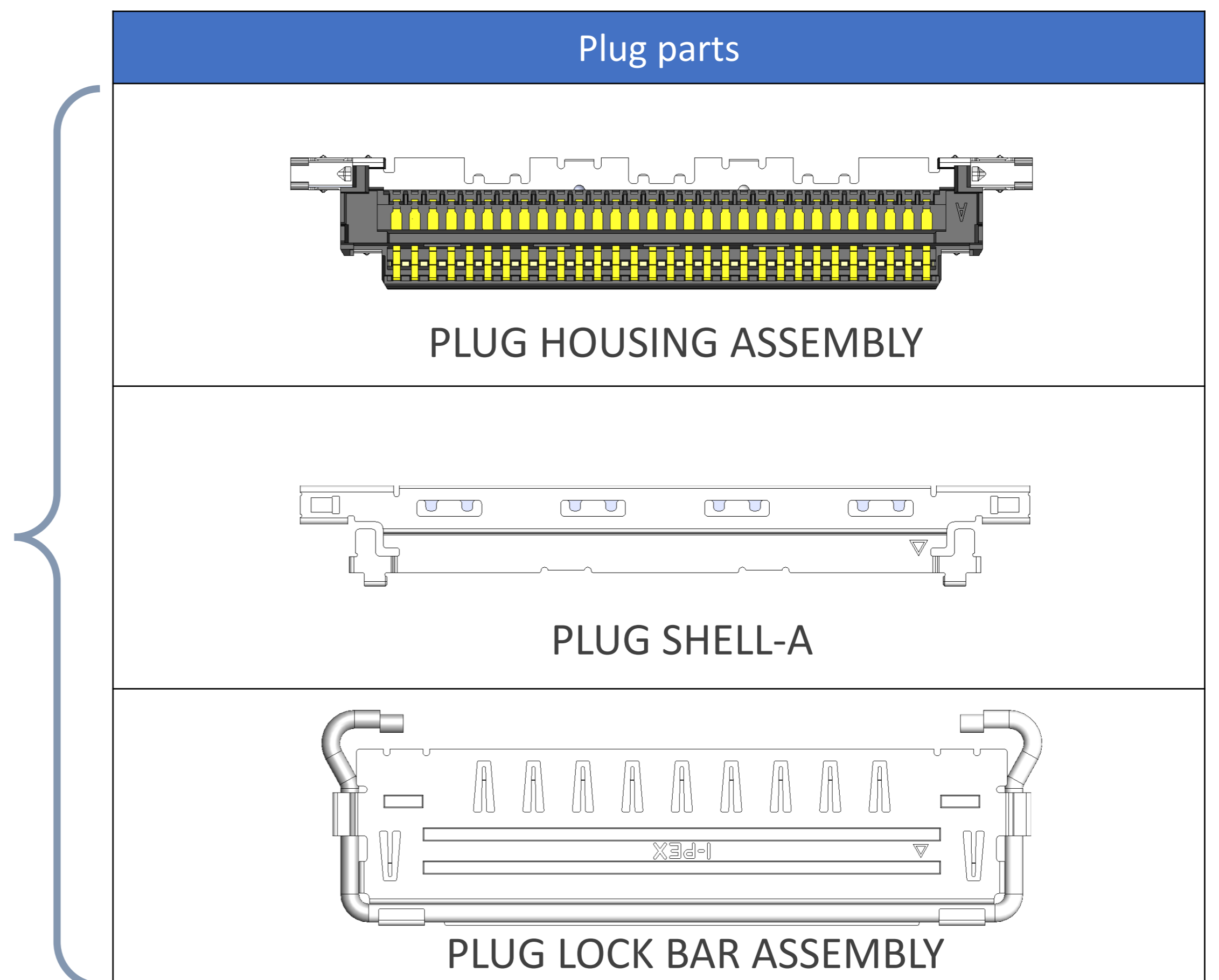
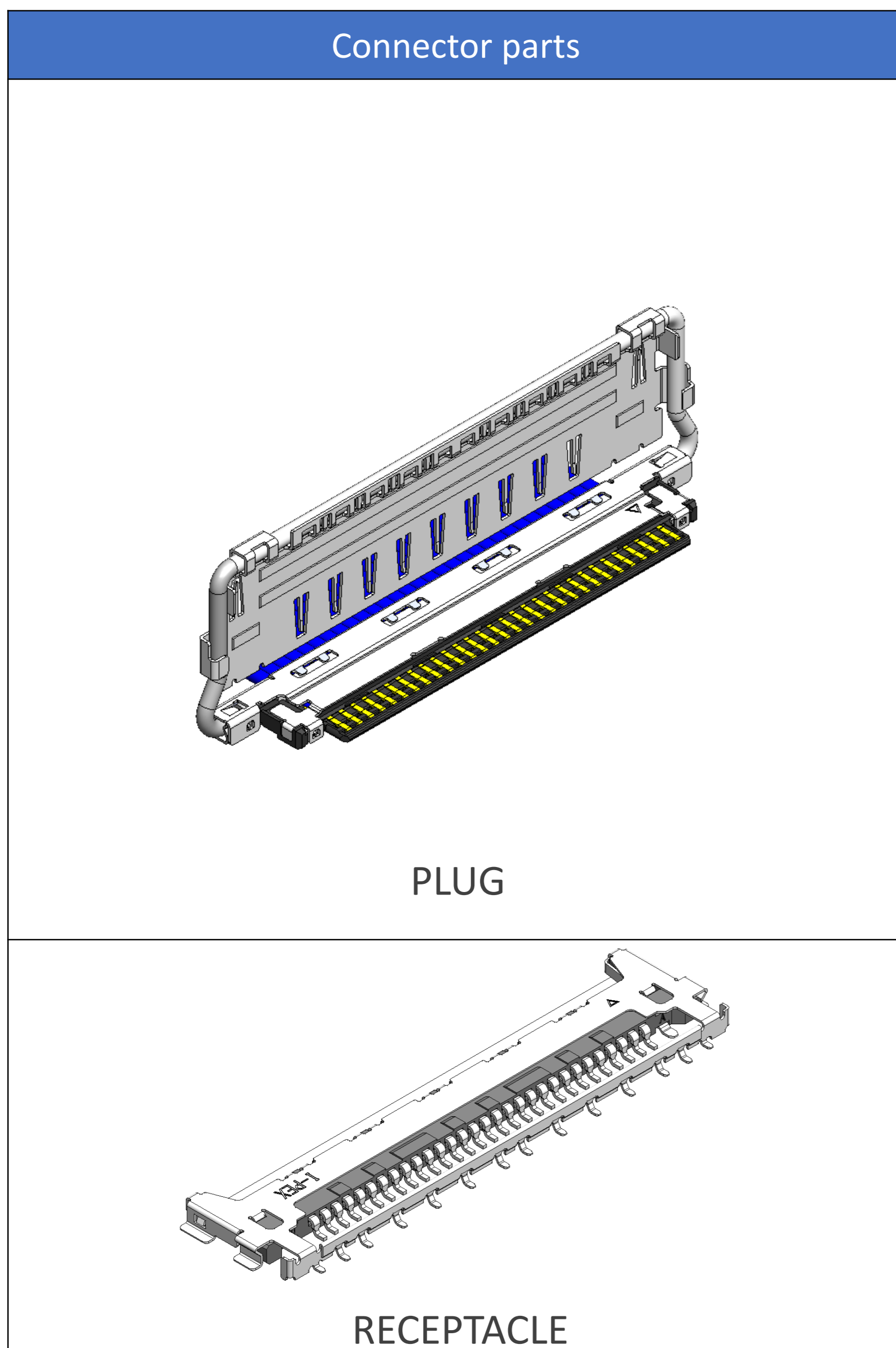

Plug for Cable Assembly

Recommended P/N		20846-0**T-01				
PART NO.	Pos.	A	B	C	D	E
20846-020T-0#	20	15.30	9.50	10.30	12.56	16.85
20846-030T-0#	30	20.30	14.50	15.30	17.56	21.85
20846-040T-0#	40	25.40	19.50	20.30	22.56	26.85

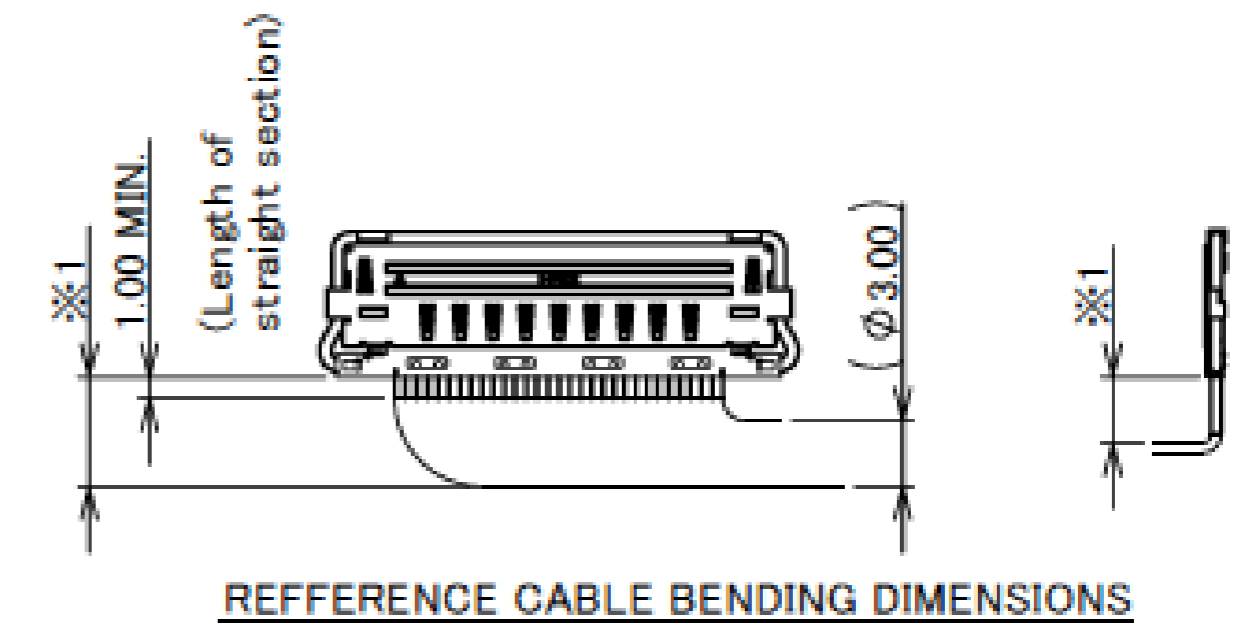
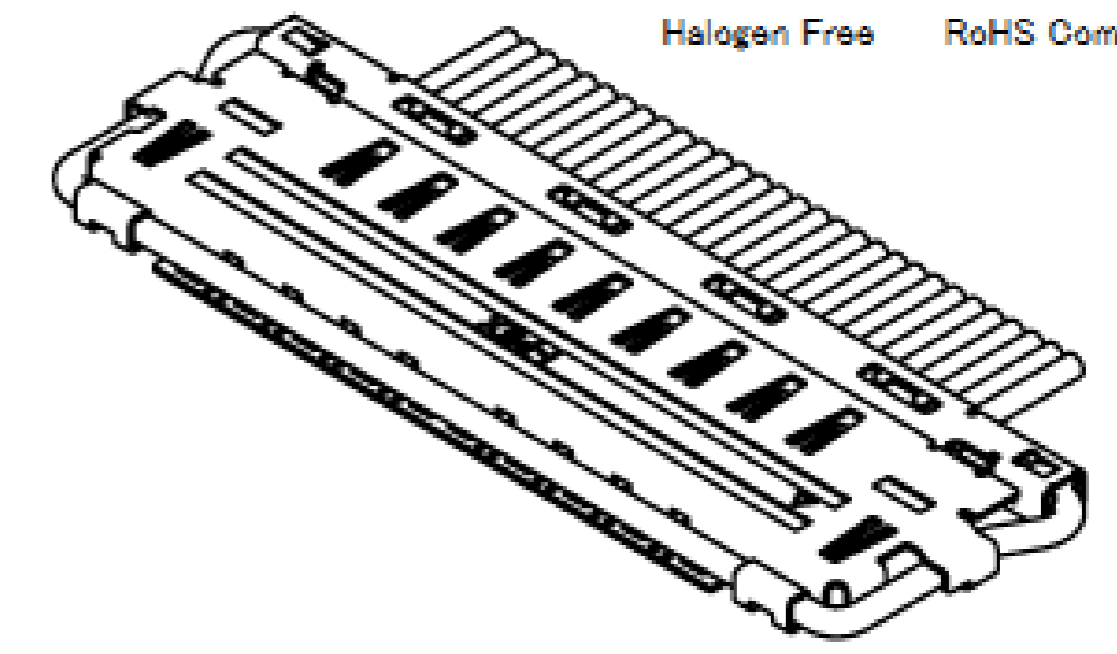
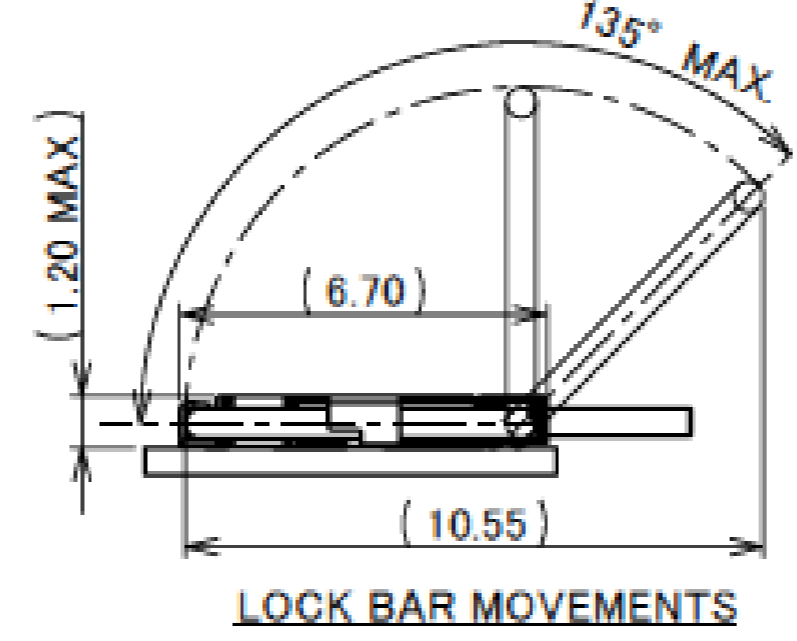
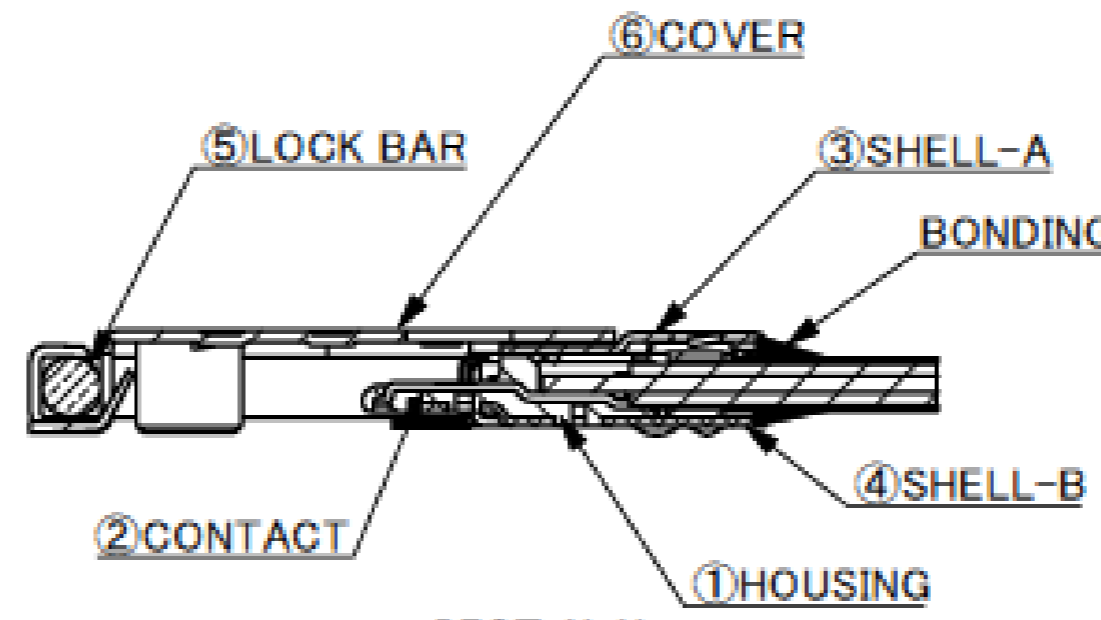
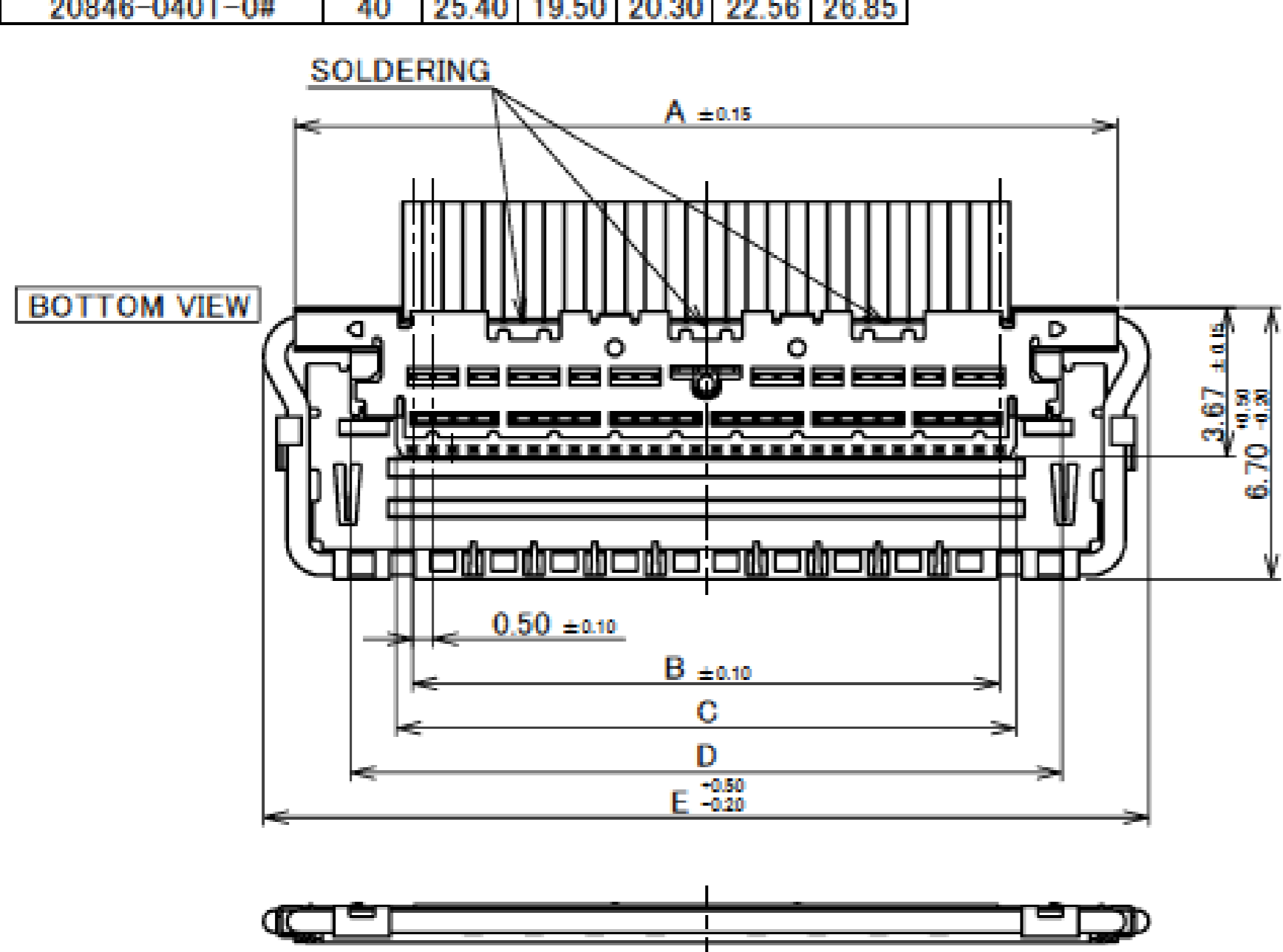

※1: THE BEND DIMENSIONS MAY VARY BASED ON THE SIZE AND QUANTITY OF CABLES. PLEASE CONFIRM THE MINIMUM BENDING RADIUS WITH I-PEX OR THE HARNESS MANUFACTURER.

TABLE 1

PART NO.	CONTACT FINISH
20846-0**T-01	CONTACT & SOLDERING AREA : Au 0.03 μm MIN. OVER Ni 1.00 μm MIN.
20846-0**T-02	CONTACT AREA : Au 0.38 μm MIN. OVER Ni 1.27 μm MIN. SOLDERING AREA : Au 0.03 μm MIN. OVER Ni 1.00 μm MIN.

NO	DISCRIPTION	MATERIAL	FINISH, REMARKS
6	COVER	PHOSPHOR BRONZE	ALL OVER Ni 1.00 μm MIN.
5	LOCK BAR	SUS	-
4	SHELL-B	PHOSPHOR BRONZE	PARTIAL Au 0.003 μm MIN. OVER Ni 1.00 μm MIN.
3	SHELL-A	PHOSPHOR BRONZE	PARTIAL Au 0.003 μm MIN. OVER Ni 1.00 μm MIN.
2	CONTACT	PHOSPHOR BRONZE	SEE TABLE 1
1	HOUSING	LCP	UL94V-0, BLACK

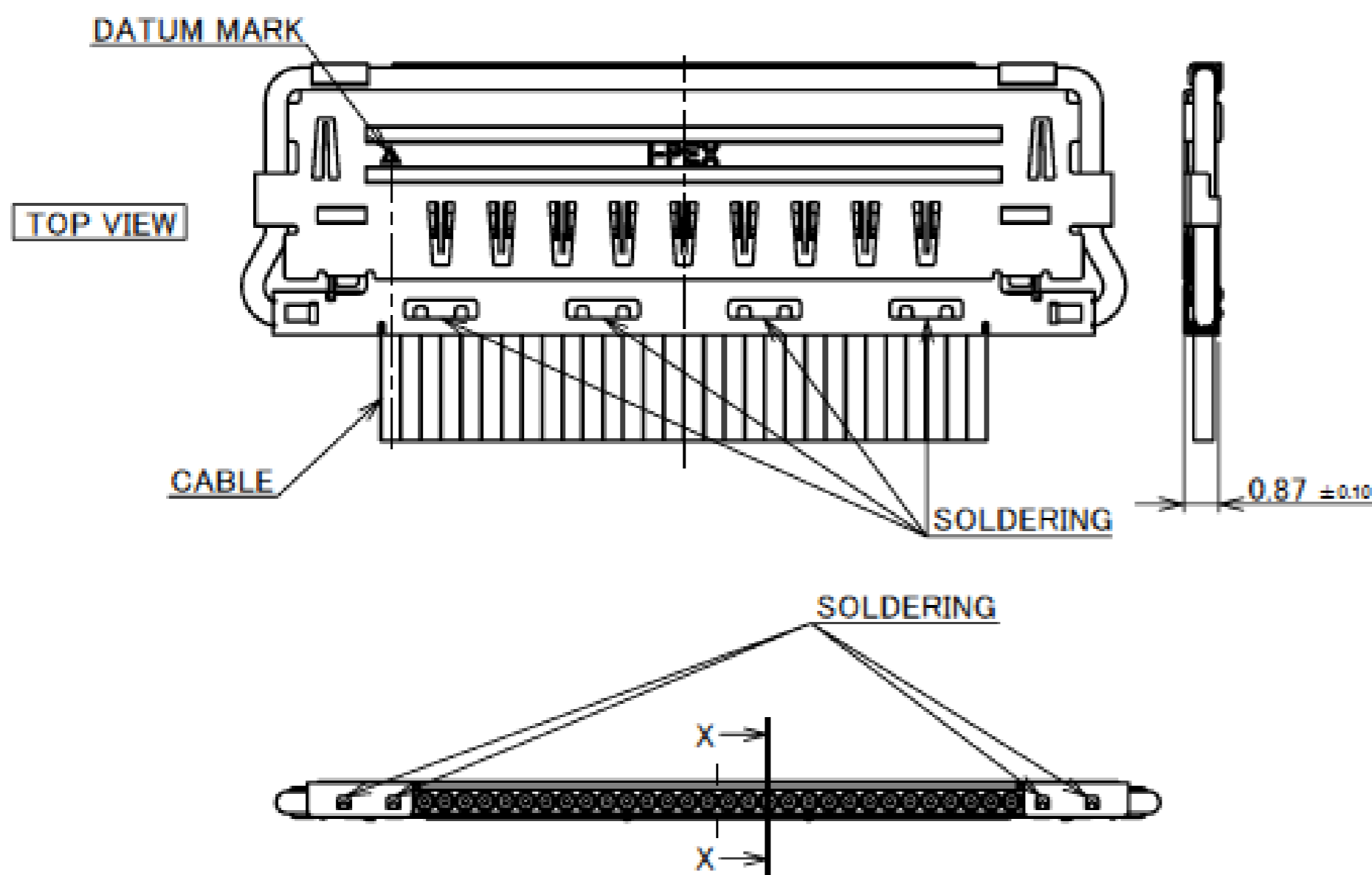

Rev.12

PART NO.	Pos.	B	G
20846-020T-0#	20	9.50	10.70
20846-030T-0#	30	14.50	15.70
20846-040T-0#	40	19.50	20.70

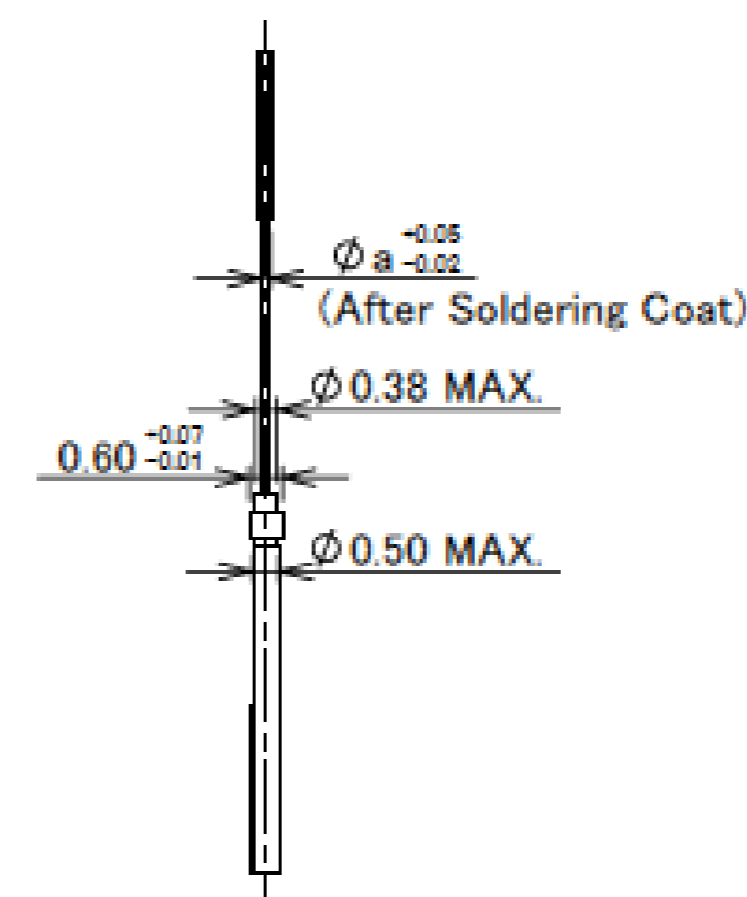
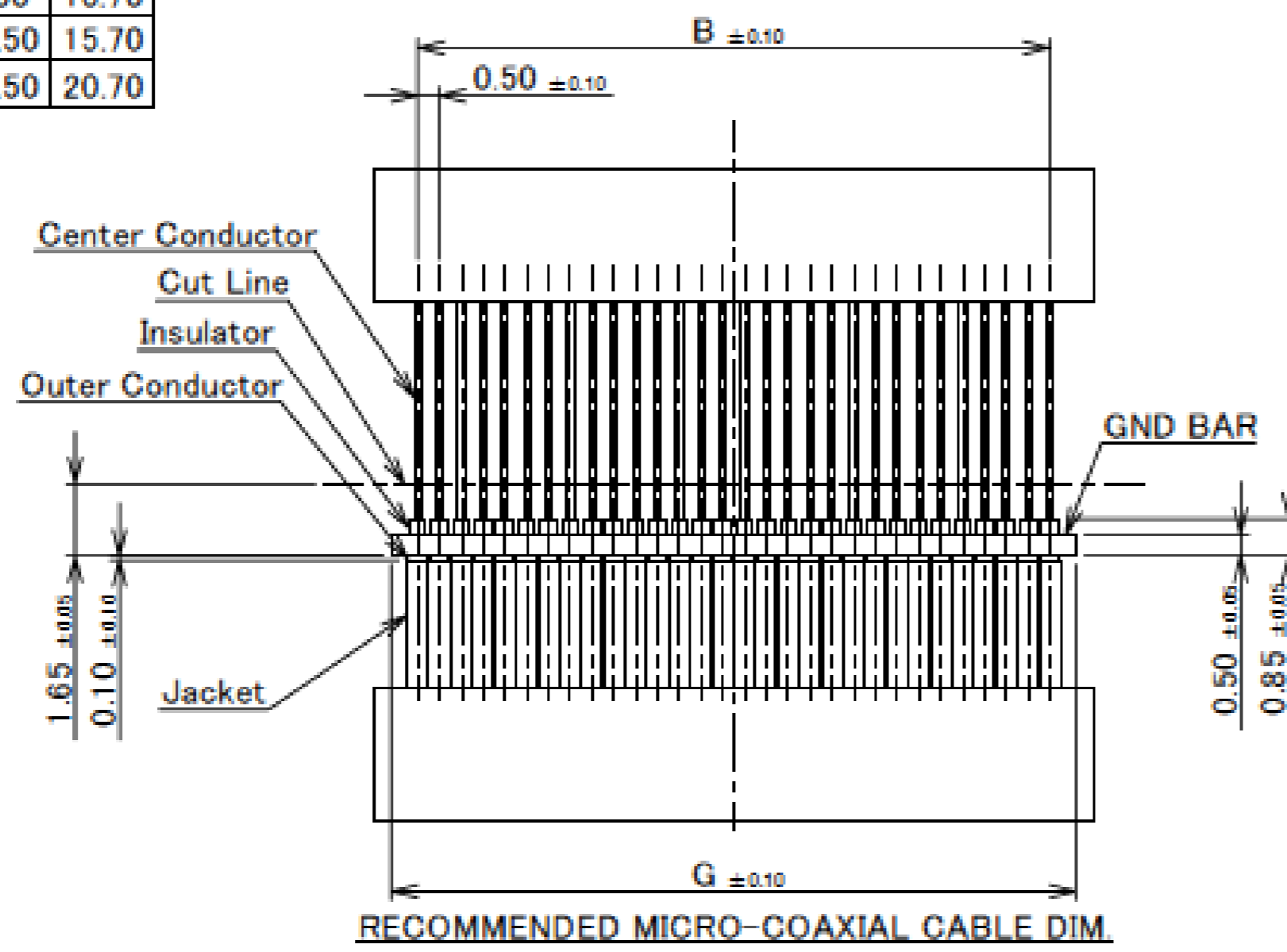

MICRO-COAXIAL CABLE DIMENSION

AWG#	a
#36	0.15
#38	0.12
#40	0.09
#42	0.075
#44	0.063

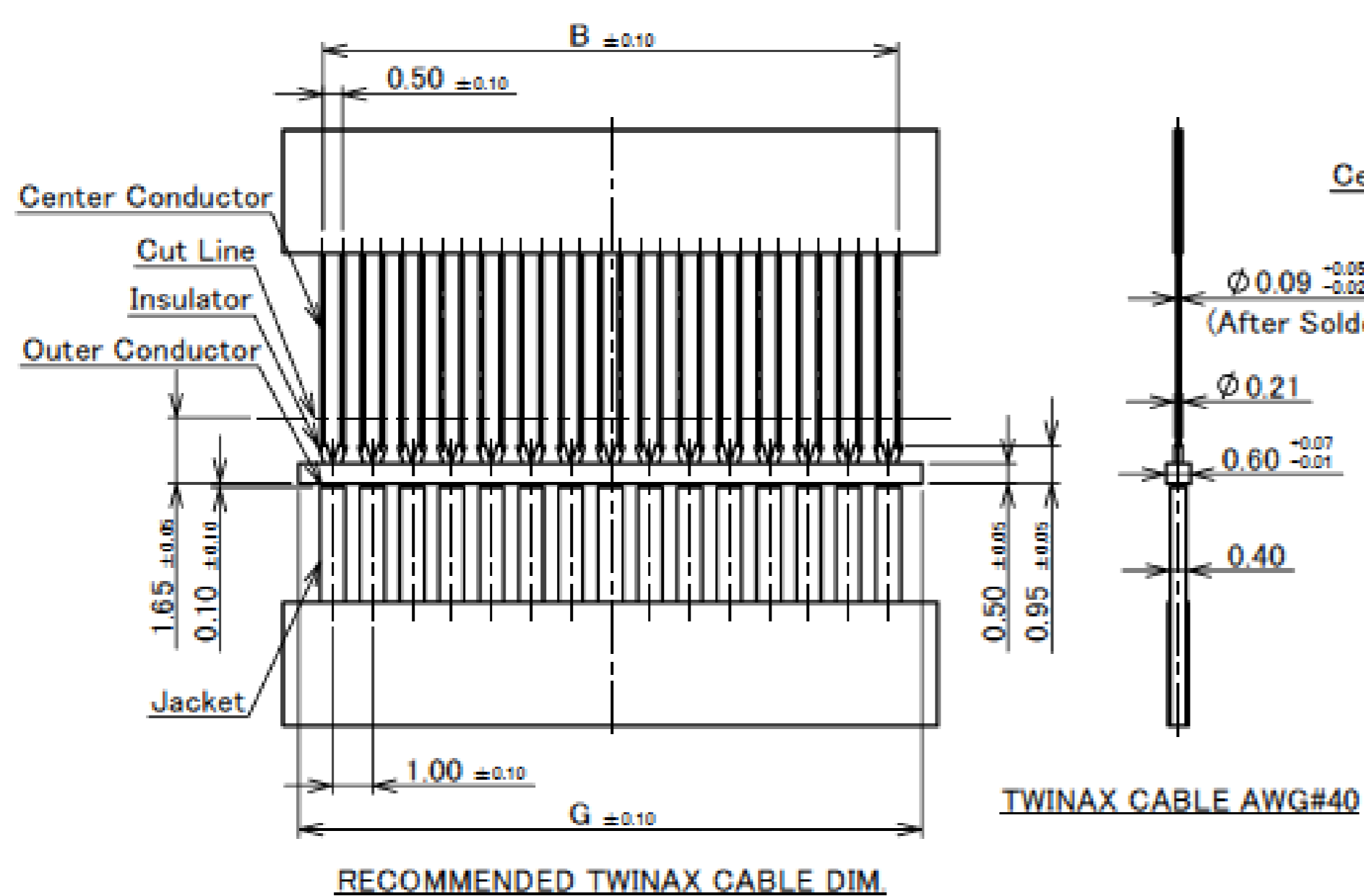

TWINAX CABLE AWG#40

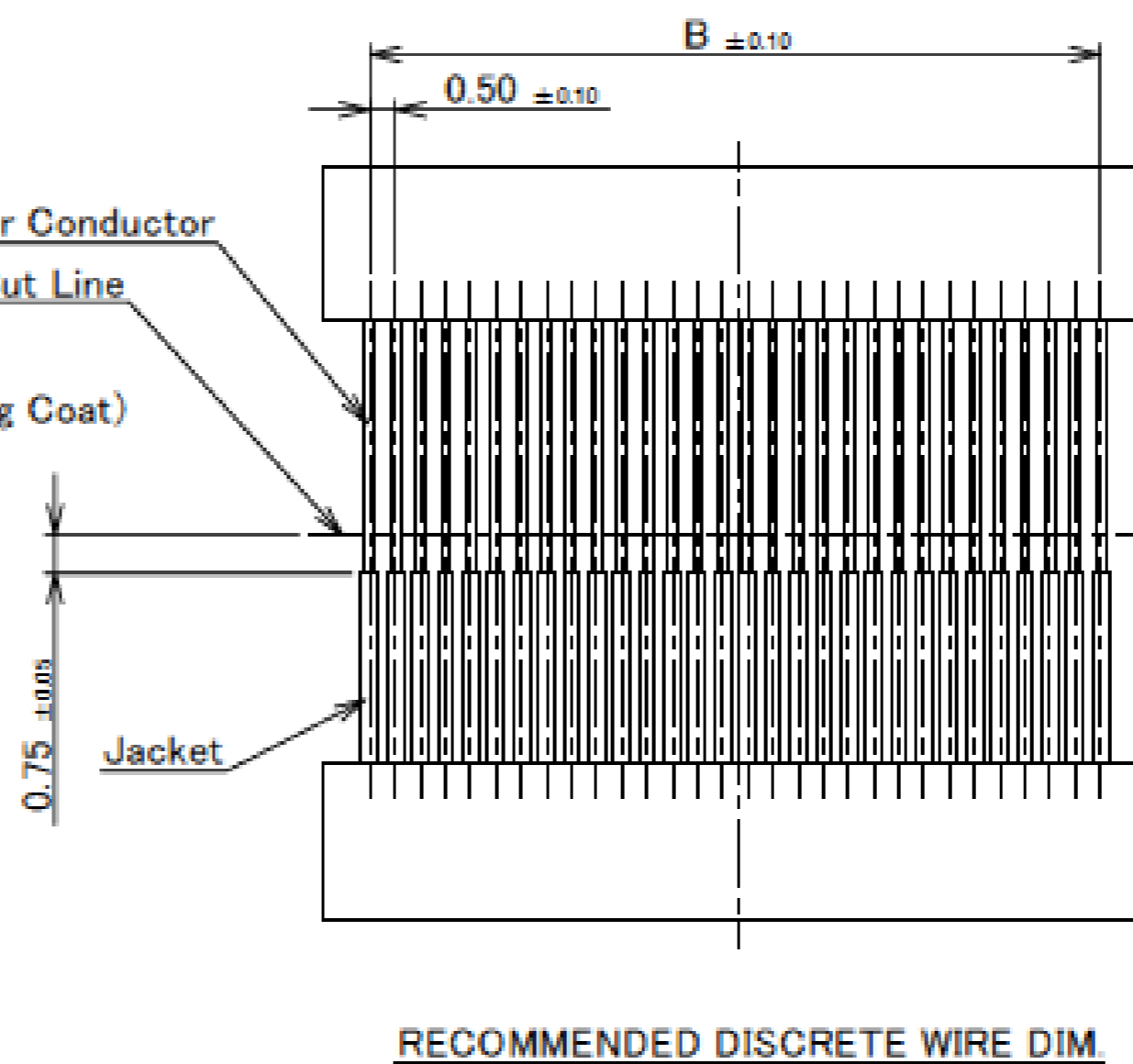

RECOMMENDED DISCRETE WIRE DIM

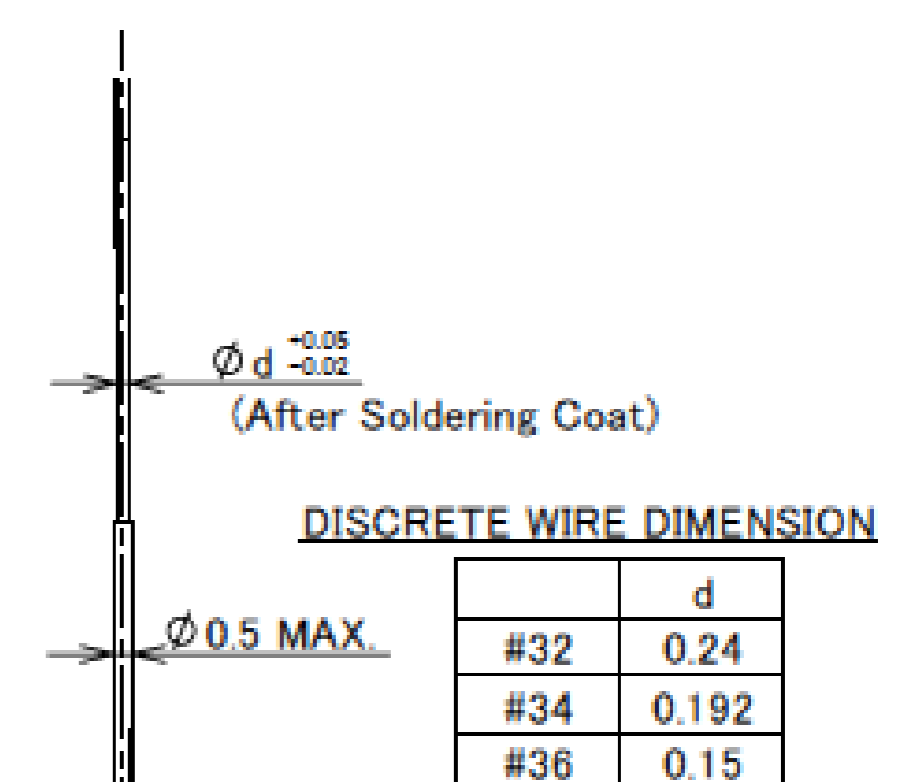

AWG#	d
#32	0.24
#34	0.192
#36	0.15

Rev.12

Plug Housing Assembly

Recommended P/N 20847-0**T-01

PART NO.	Pos.	A	B	C	D	E	F	G	H	J	K
20847-020T-0#	20	-	-	5.00	15.30	11.00	10.55	10.20	9.50	10.30	12.56
20847-030T-0#	30	4.50	4.50	9.00	20.30	16.00	15.55	15.20	14.50	15.30	17.56
20847-040T-0#	40	9.00	4.50	13.50	25.40	21.00	20.55	20.20	19.50	20.30	22.56

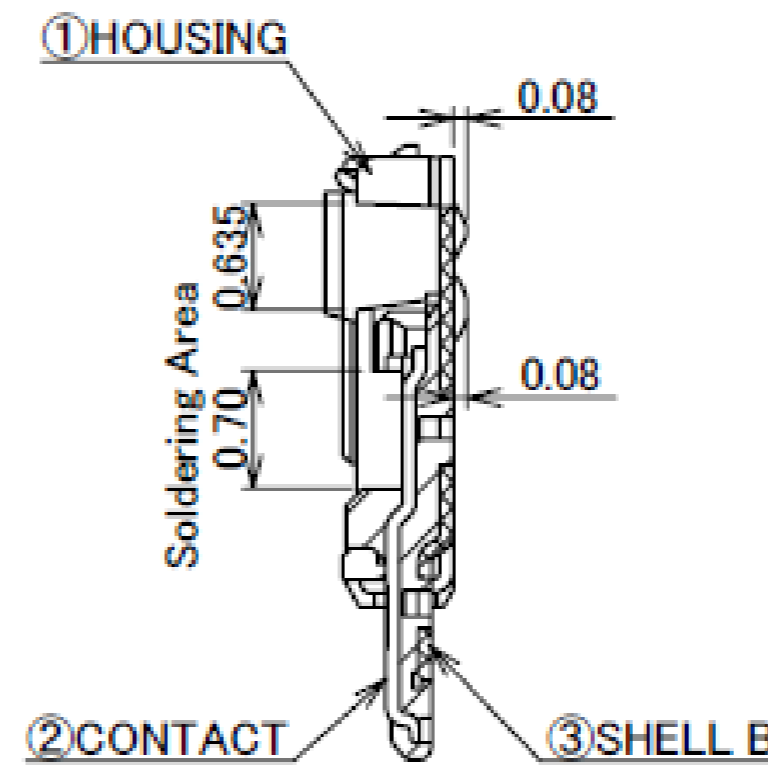
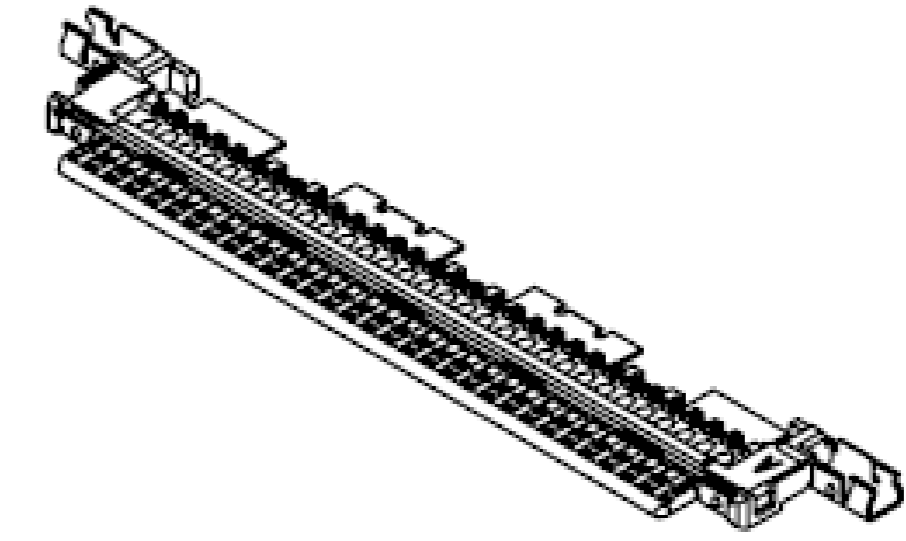
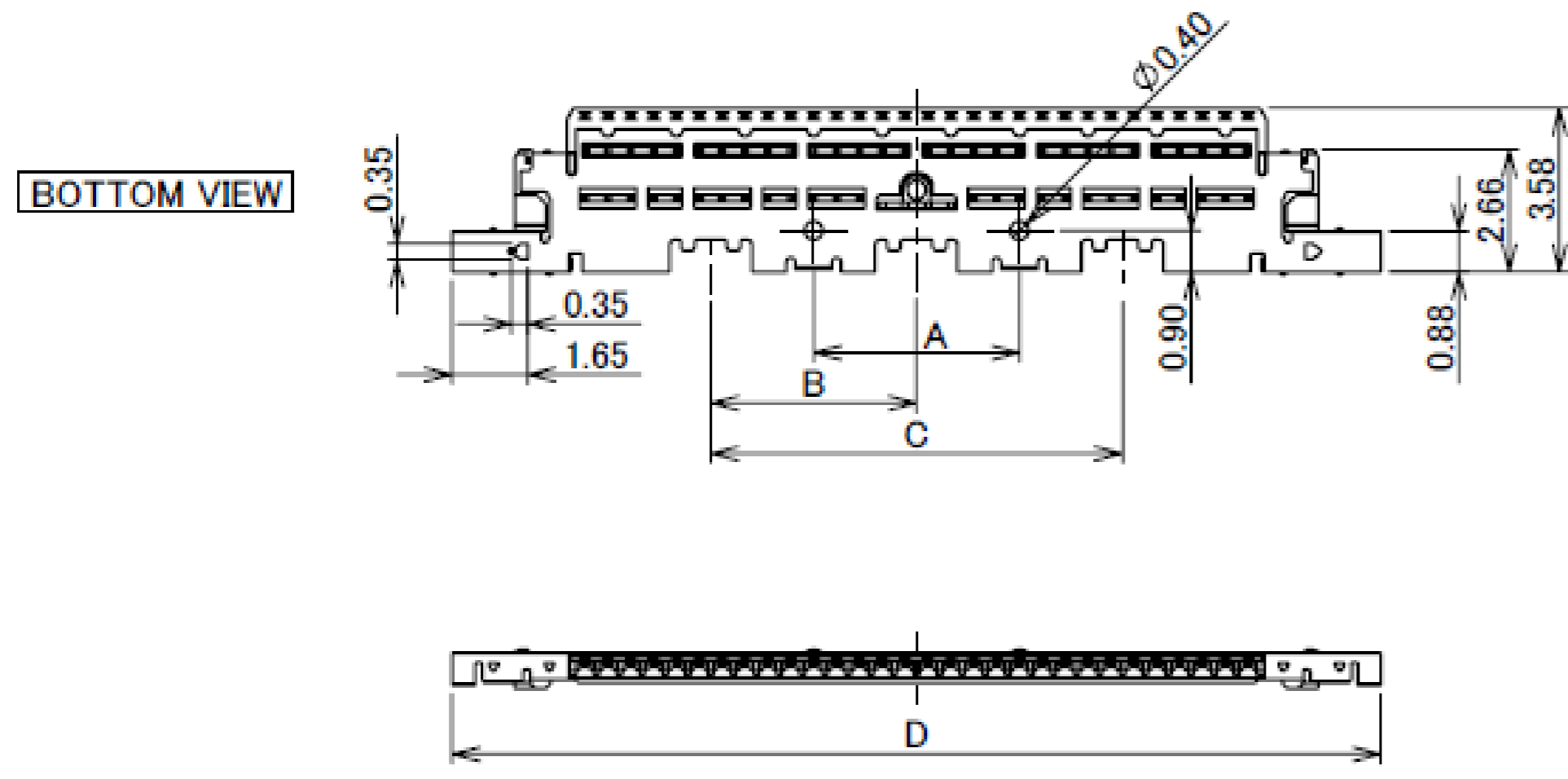
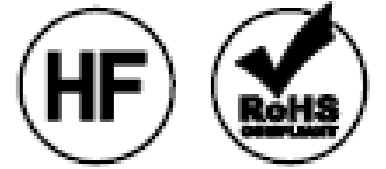

SECT. X-X
(S=15/1)

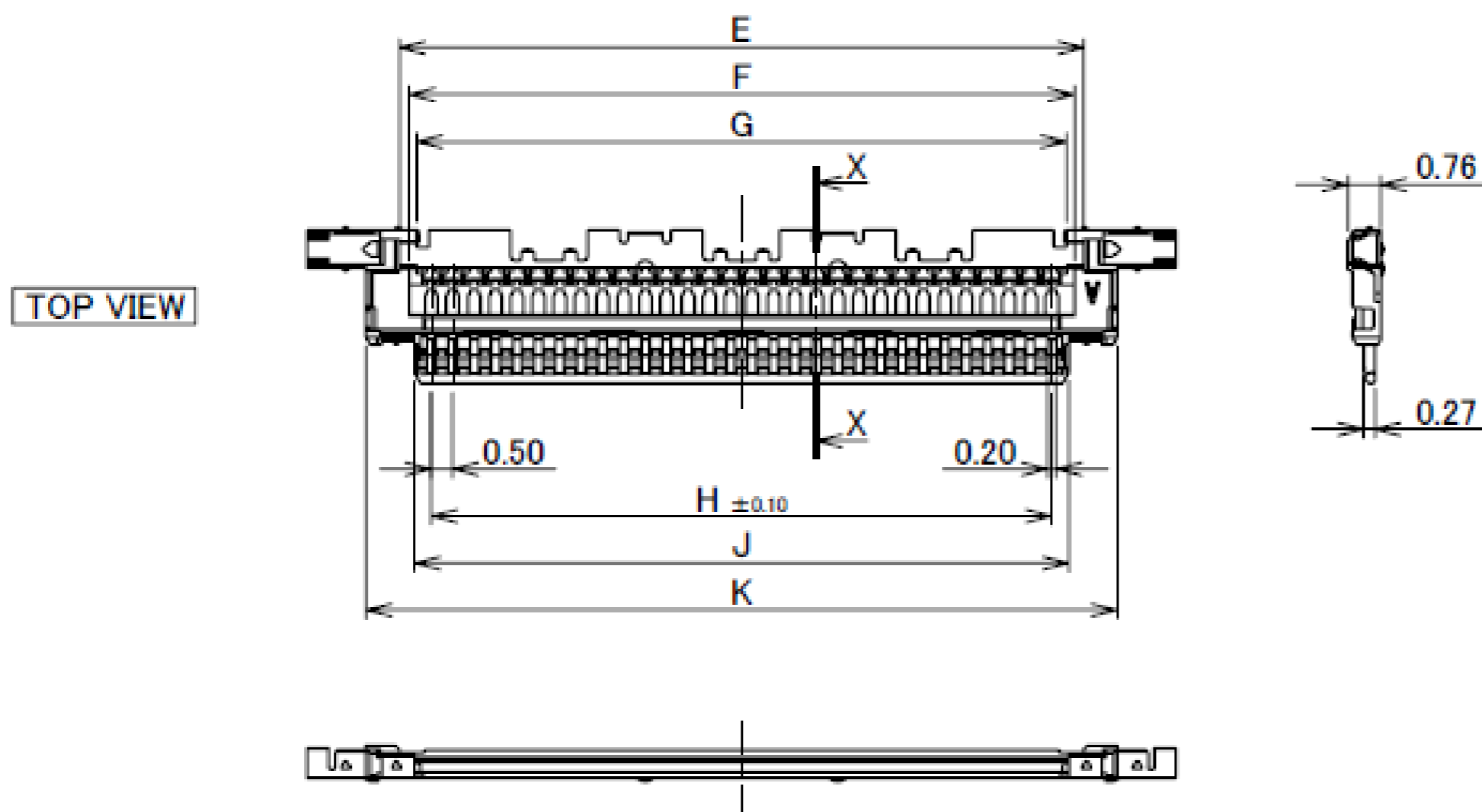

NOTES.

- THIS PART IS ASSEMBLED WITH SHELL A(P/N 3427-0**1) AND LOCK BAR ASSY(P/N 20848-0**T-01) AFTER SOLDERING THE CABLE, AND SHALL BE ASSIGNED AS P/N 20846-0**T-0#

TABLE 1

PART NO.	CONTACT FINISH
20847-0**T-01	CONTACT & SOLDERING AREA : Au 0.03 μm MIN. OVER Ni 1.00 μm MIN.
20847-0**T-02	CONTACT AREA : Au 0.38 μm MIN. OVER Ni 1.27 μm MIN. SOLDERING AREA : Au 0.03 μm MIN. OVER Ni 1.00 μm MIN.

Rev.6

Plug Shell-A

Recommended P/N 3427-0**1

PART No.	Pos.	A	B	C	D	E
3427-0201	20	15.30	9.78	12.56	3.00	6.00
3427-0301	30	20.30	14.78	17.56	4.00	12.00
3427-0401	40	25.40	19.88	22.56	4.00	16.00

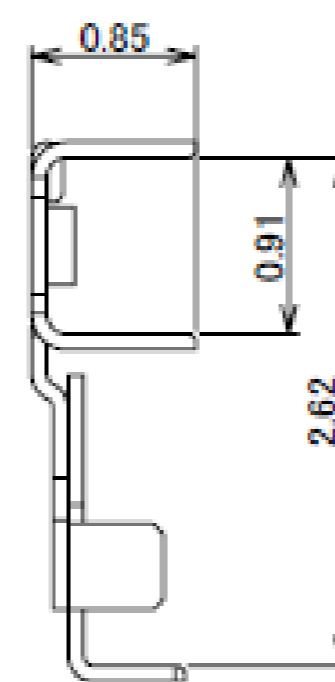
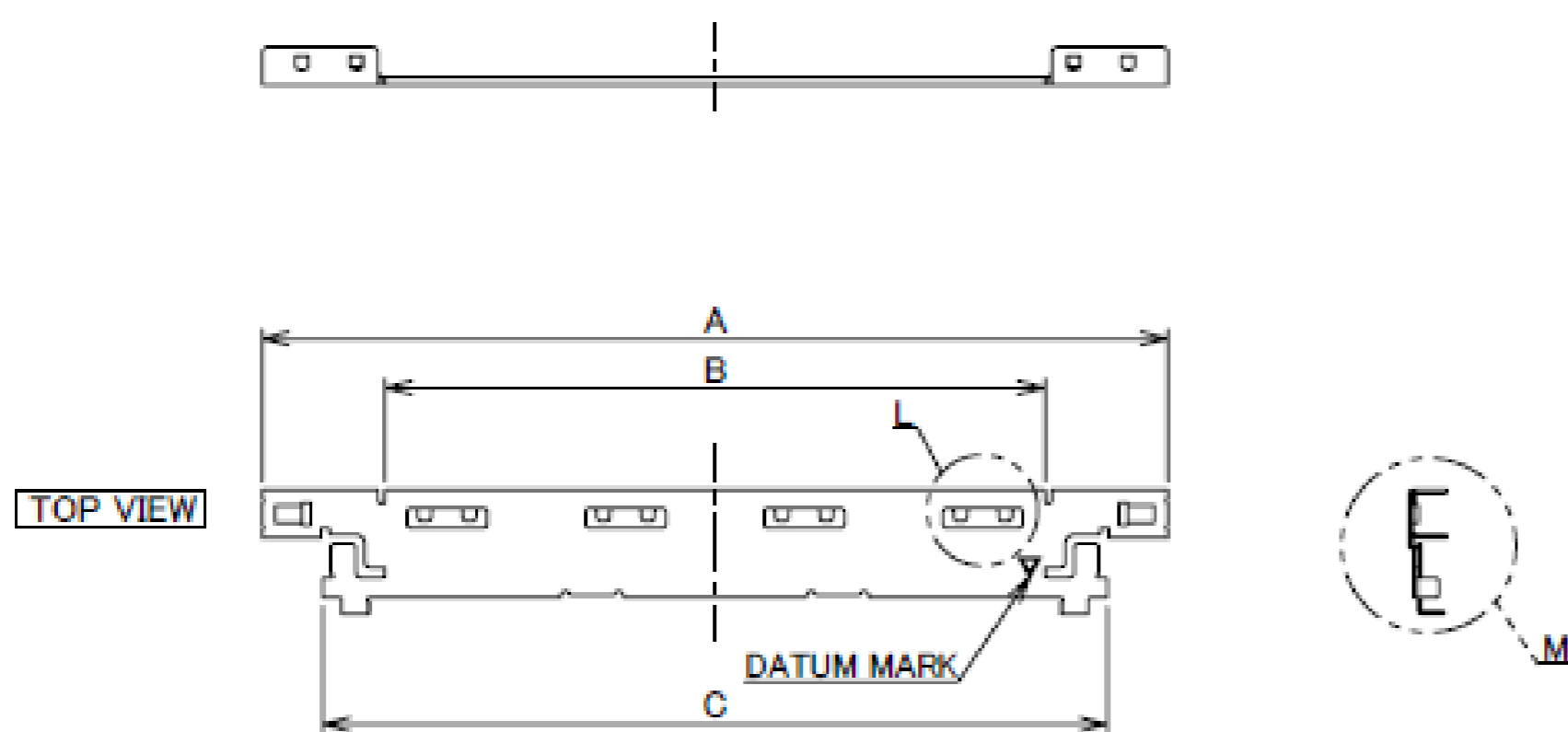
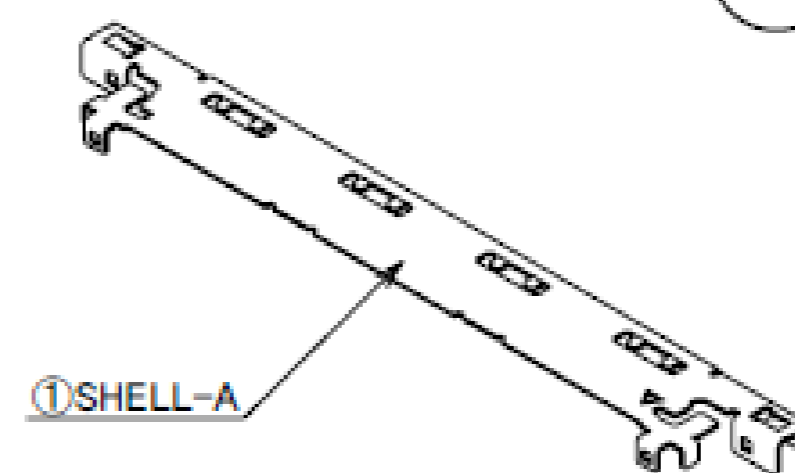

VIEW M
(S=20/1)

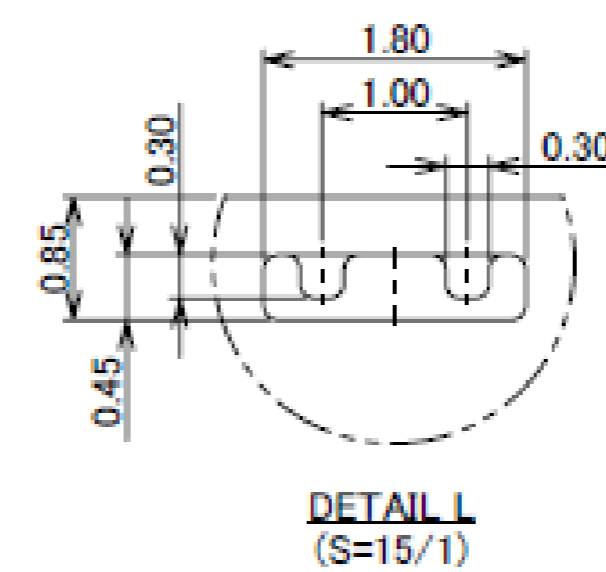
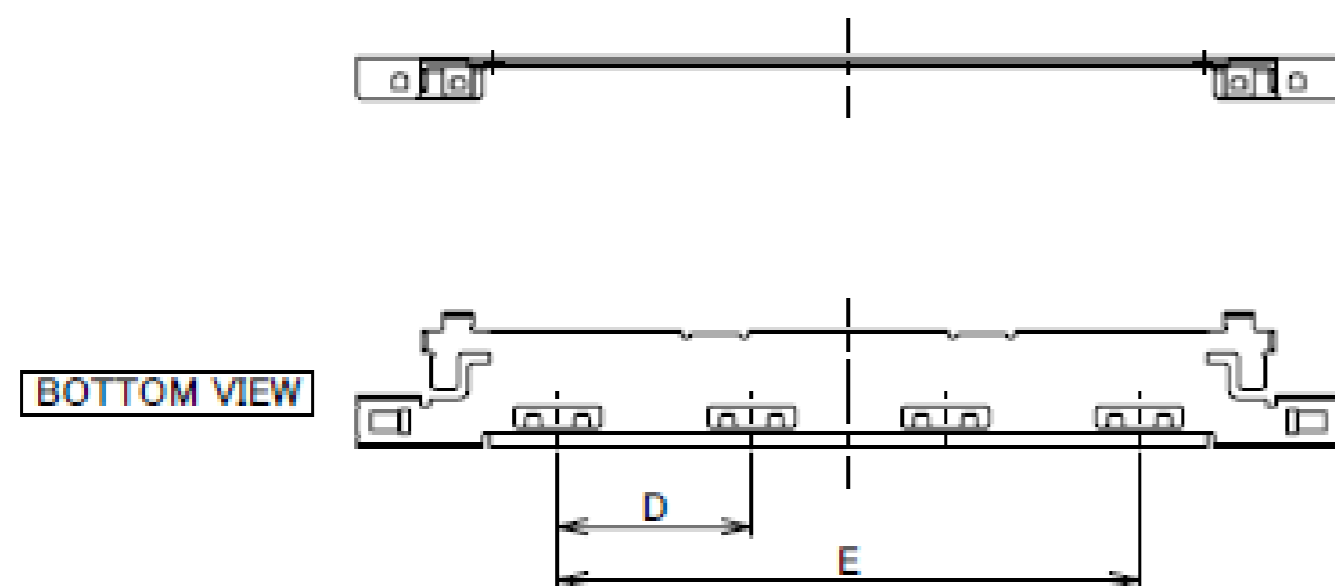

DETAIL L
(S=15/1)

NO.	DISCRIPTION	MATERIAL	FINISH , REMARKS
1	SHELL-A	PHOSPHOR BRONZE	PARTIAL Au 0.003 μm MIN. OVER Ni 1.00 μm MIN.

Rev.3

Plug Lock Bar Assembly

Recommended P/N		20848-0**T-01				
PART NO.	Pos.	A	B	C	D	E
20848-020T-01	20	14.59	12.70	7.50	15.75	7.00
20848-030T-01	30	19.59	17.70	12.00	20.75	12.00
20848-040T-01	40	24.59	22.70	18.00	25.75	17.00

20848-0**T-01
POS.

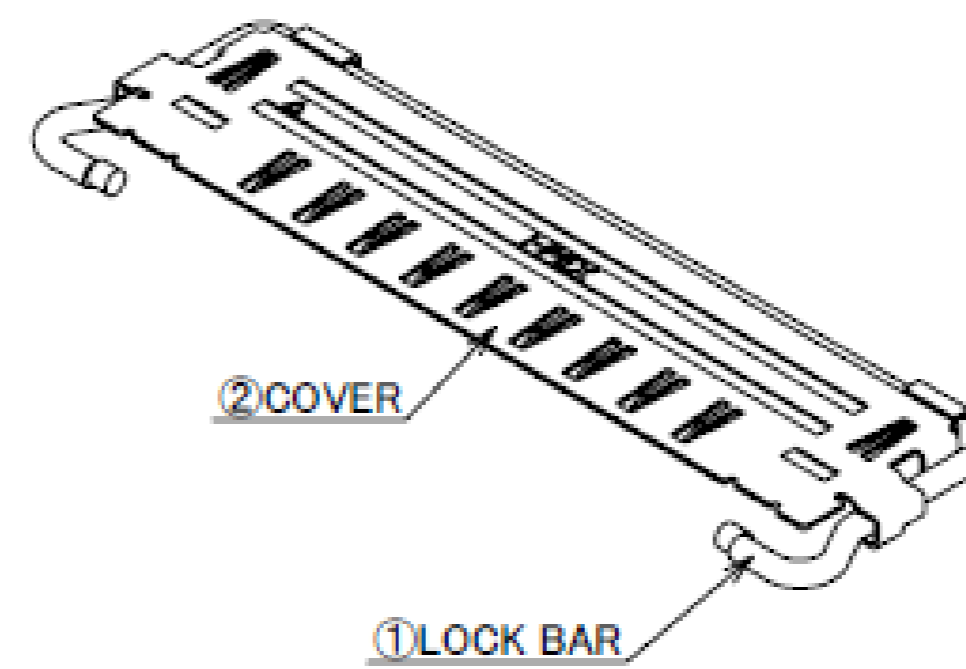
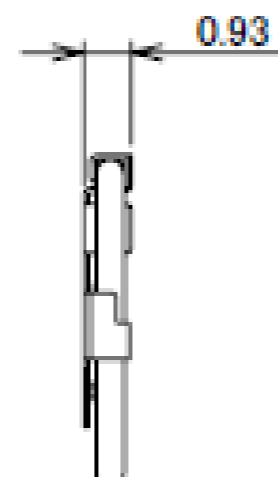
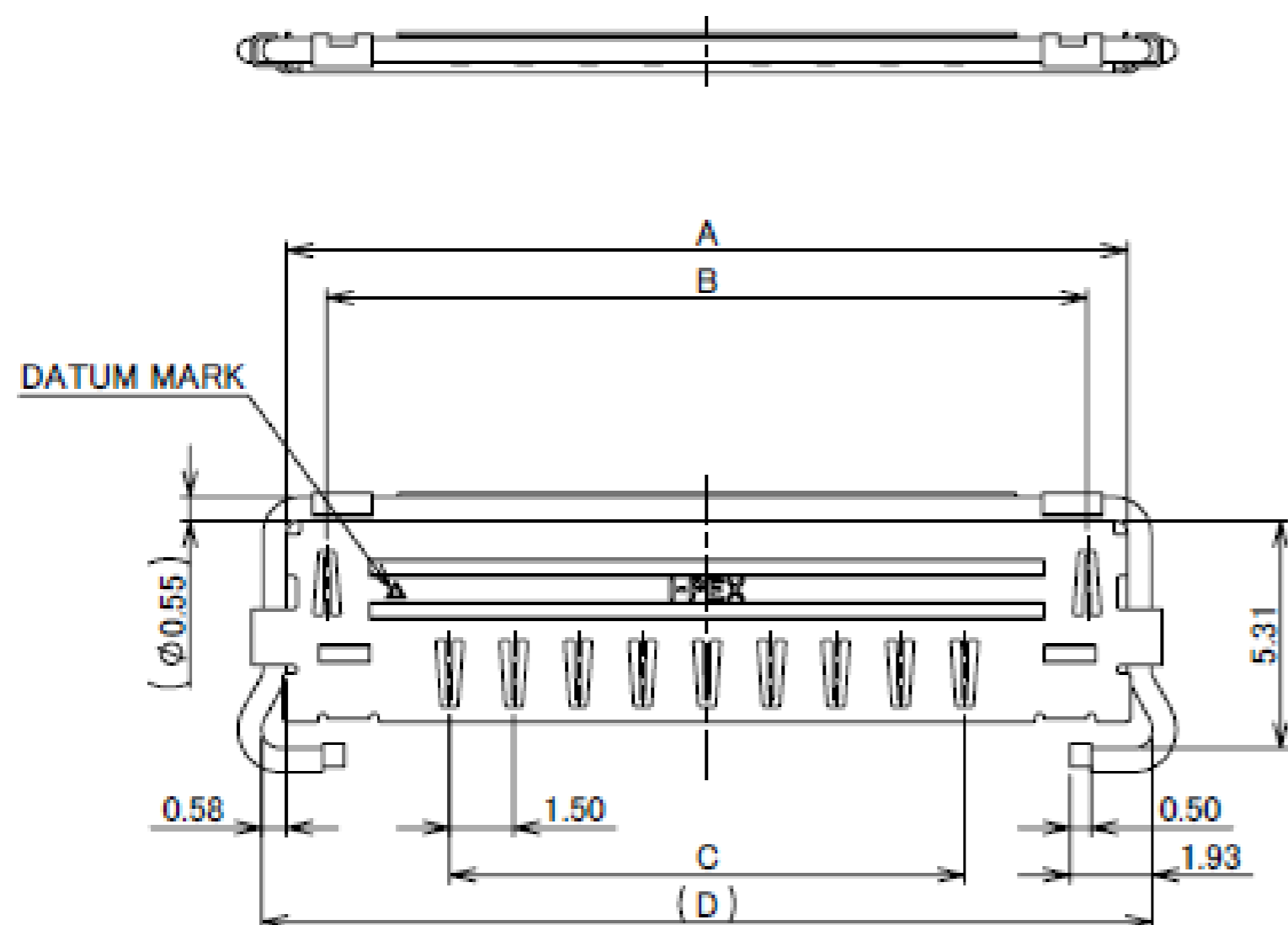

NO.	DISCRIPTION	MATERIAL	FINISH , REMARKS
2	COVER	PHOSPHOR BRONZE	ALL OVER Ni 1.00 μm MIN.
1	LOCK BAR	SUS φ0.55	-

Rev.6

Receptacle Assembly

Recommended P/N		20849-0**E-01				
PART NO.	Pos.	A	B	C	D	E
20849-020E-0#	20	11.30	9.50	14.33	15.10	11.91
20849-030E-0#	30	16.30	14.50	19.33	20.10	16.91
20849-040E-0#	40	21.30	19.50	24.33	25.10	21.91

P/N : 20849- 0** E- 0#
SEE TABLE 1
POS.

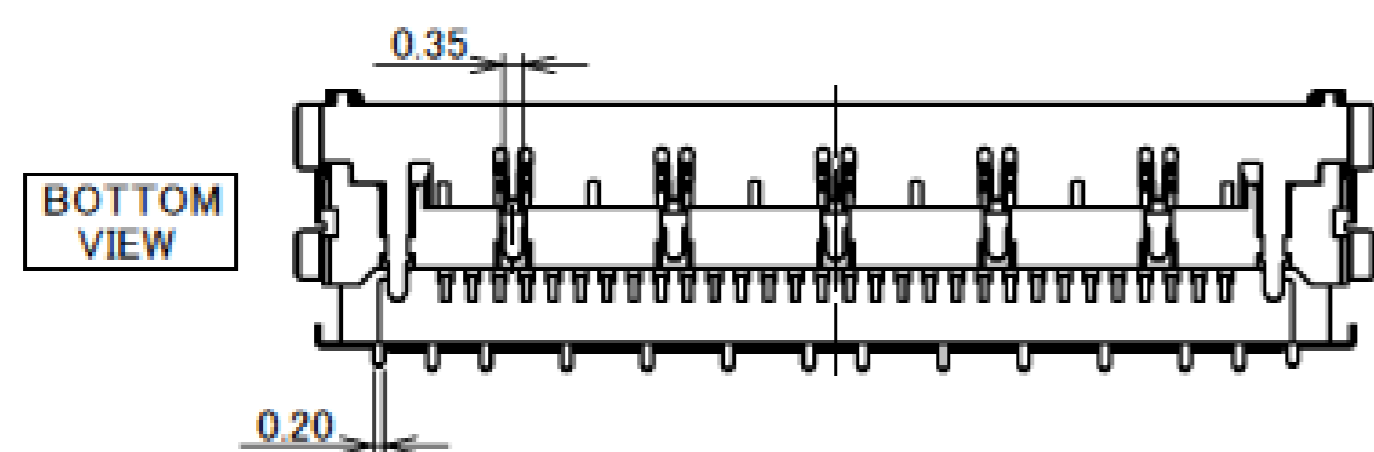
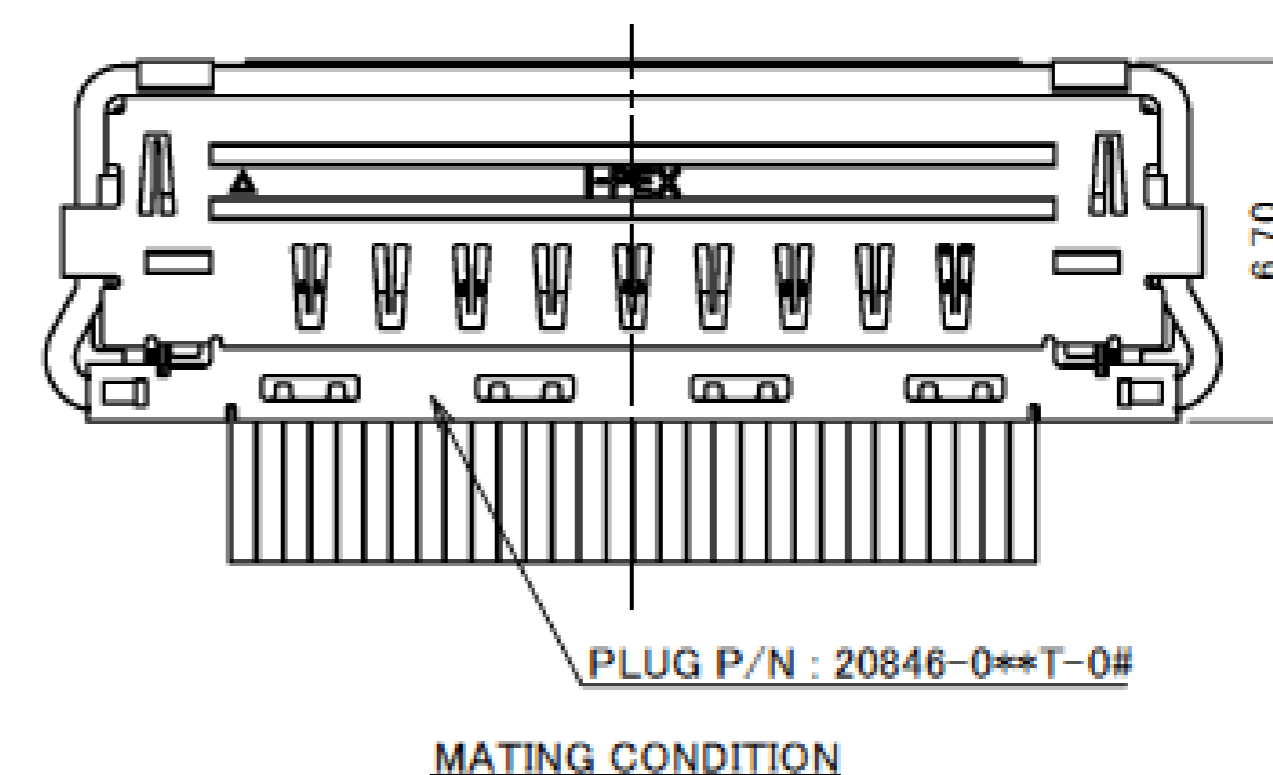
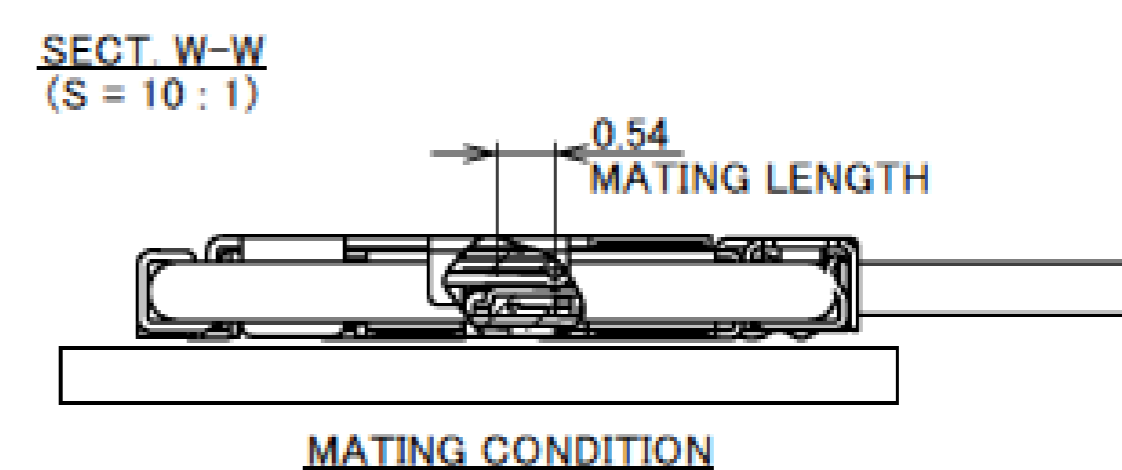
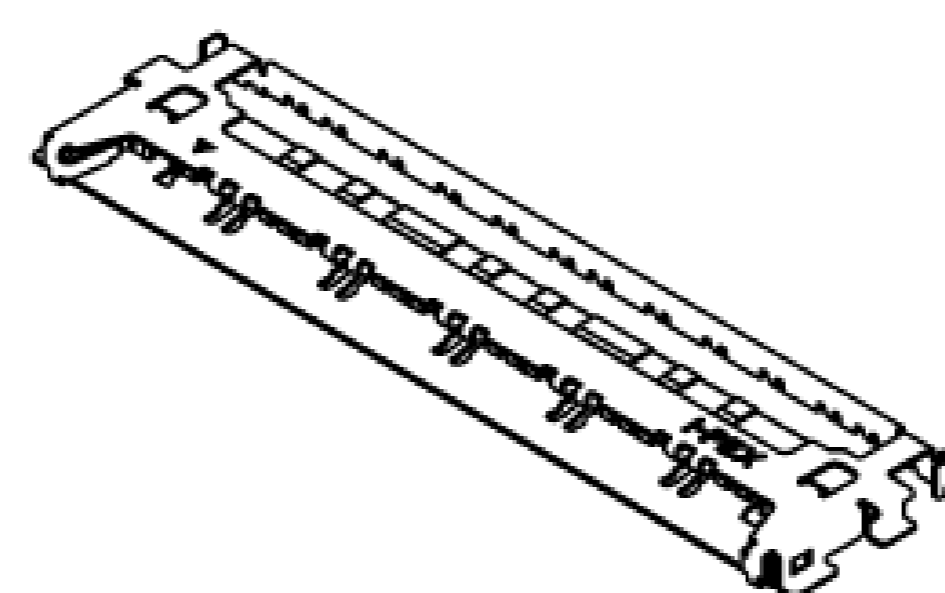
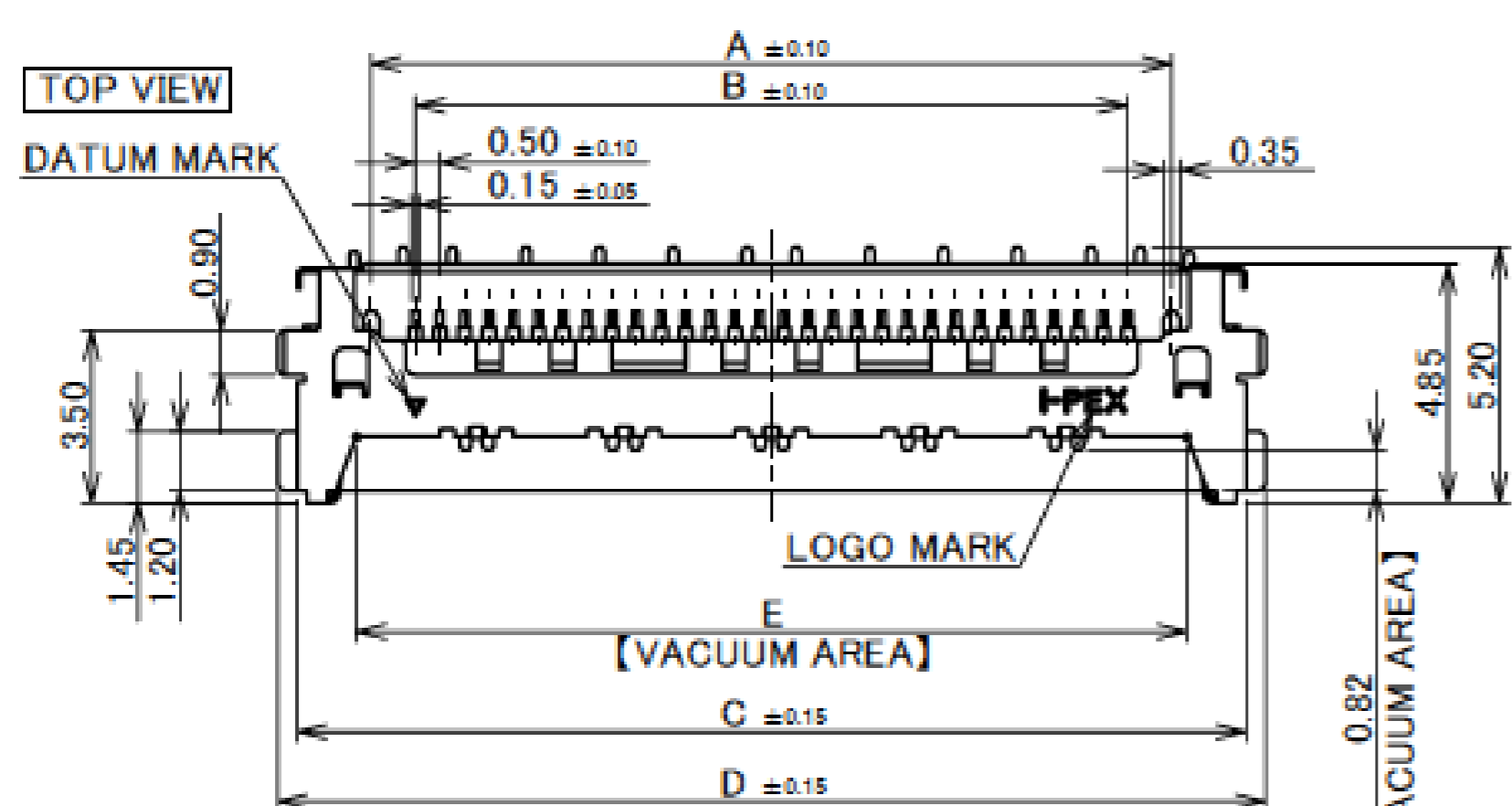
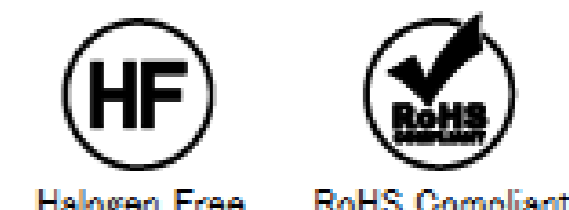
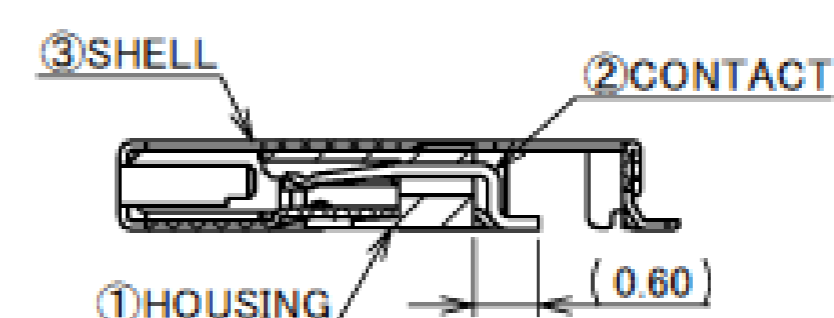

TABLE.1

PART NO.	CONTACT FINISH	SHELL FINISH
20849-0**E-01	CONTACT & SOLDERING AREA : Au 0.03 μm MIN. OVER Ni 1.00 μm MIN.	ALL OVER Ni 1.00 μm MIN.
20849-0**E-02	CONTACT AREA : Au 0.38 μm MIN. OVER Ni 1.27 μm MIN. SOLDERING AREA : Au 0.03 μm MIN. OVER Ni 1.00 μm MIN.	SOLDERING AREA : Au 0.02 μm MIN.

NO.	DISCRIPTION	MATERIAL	FINISH , REMARKS
3	SHELL	PHOSPHOR BRONZE	SEE TABLE 1
2	CONTACT	PHOSPHOR BRONZE	SEE TABLE 1
1	HOUSING	LCP	UL94V-0. BLACK

Rev.11

Receptacle Assembly

PART NO.	Pos.
20849-020E-0#	20
20849-030E-0#	30
20849-040E-0#	40

BOTTOM VIEW

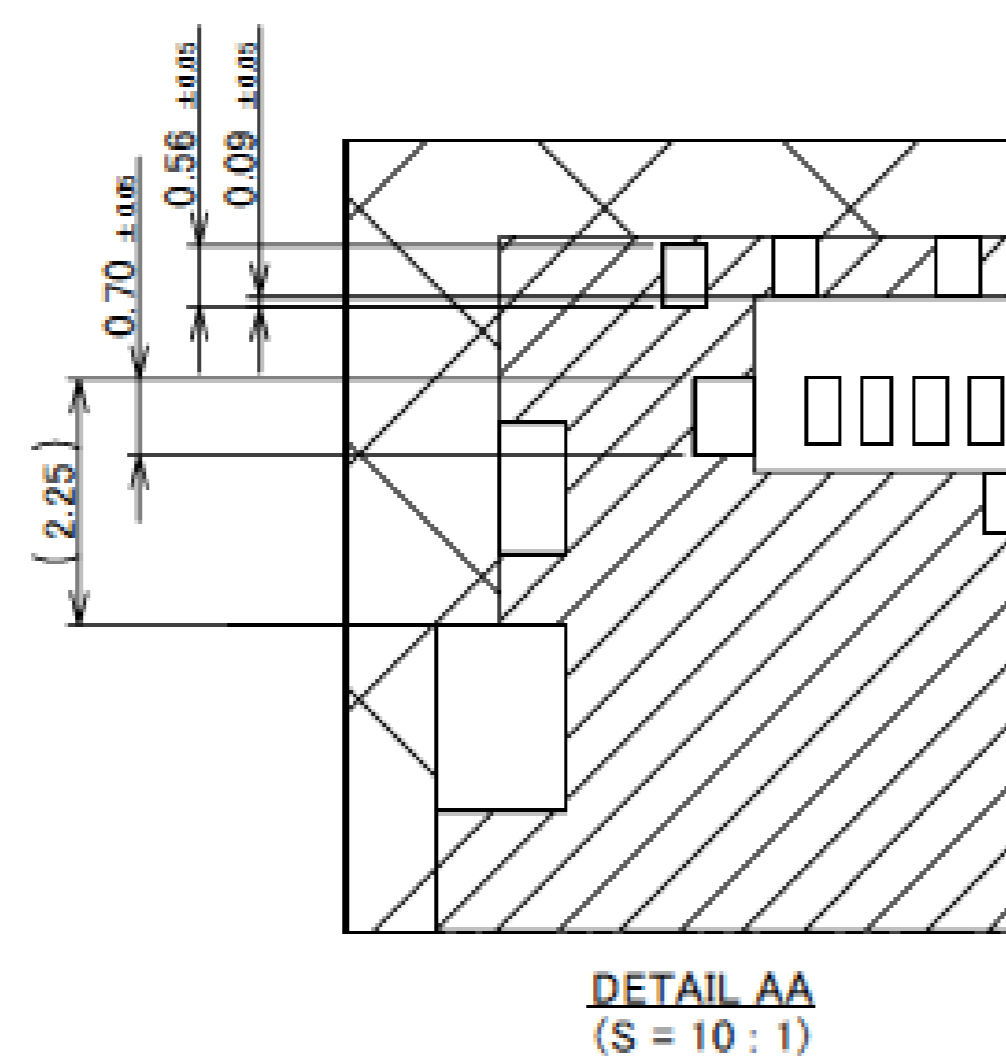
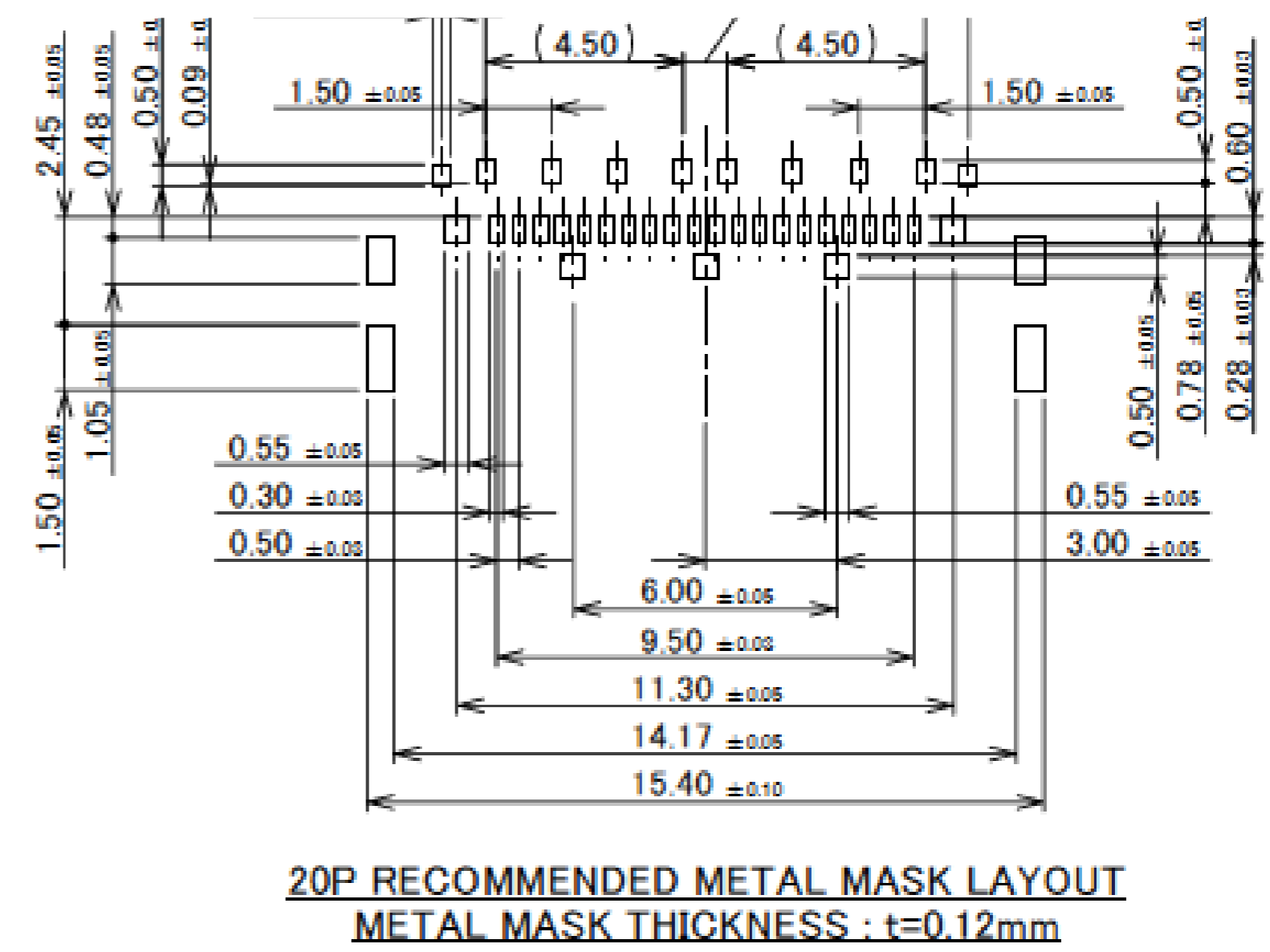
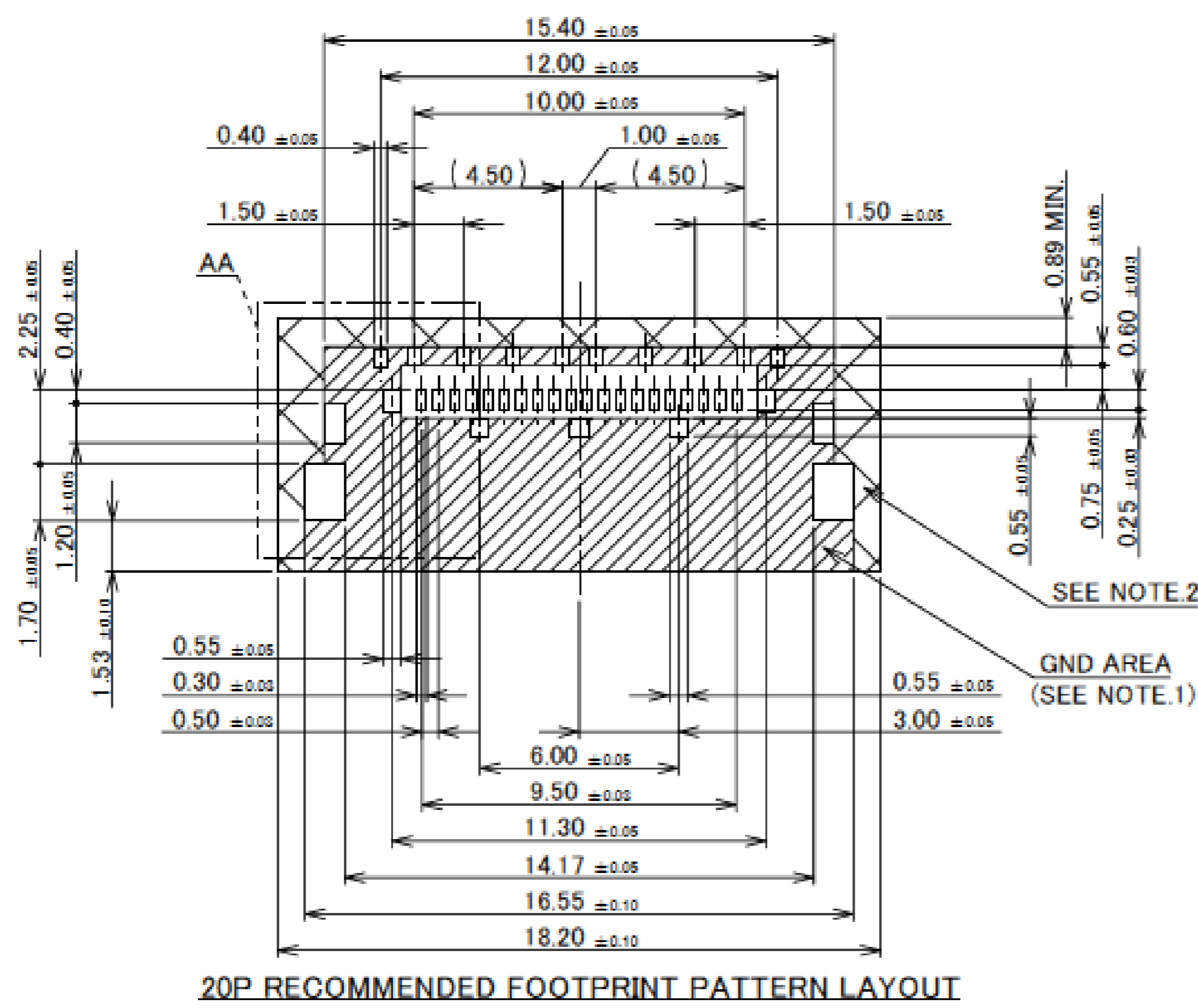
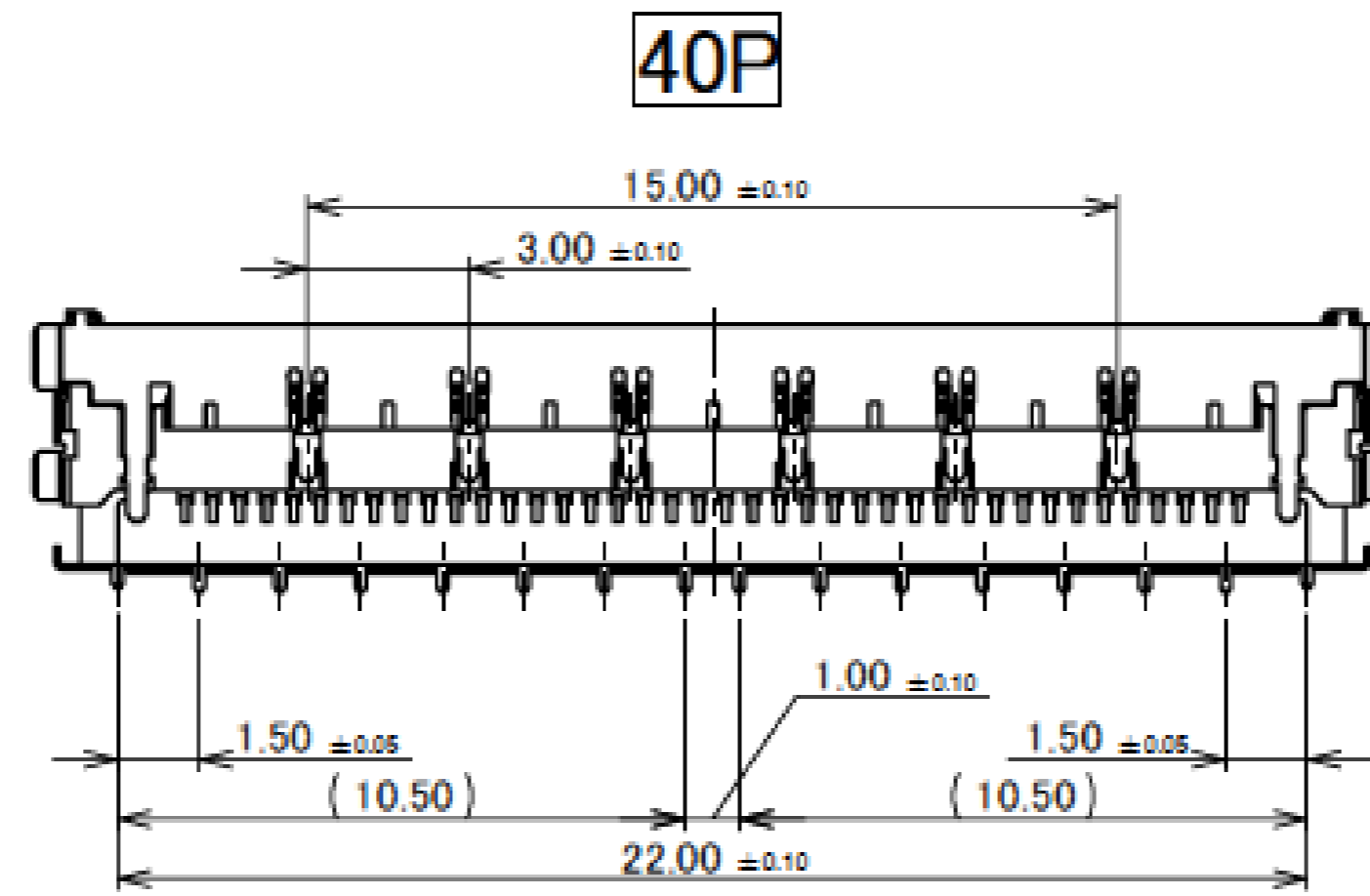
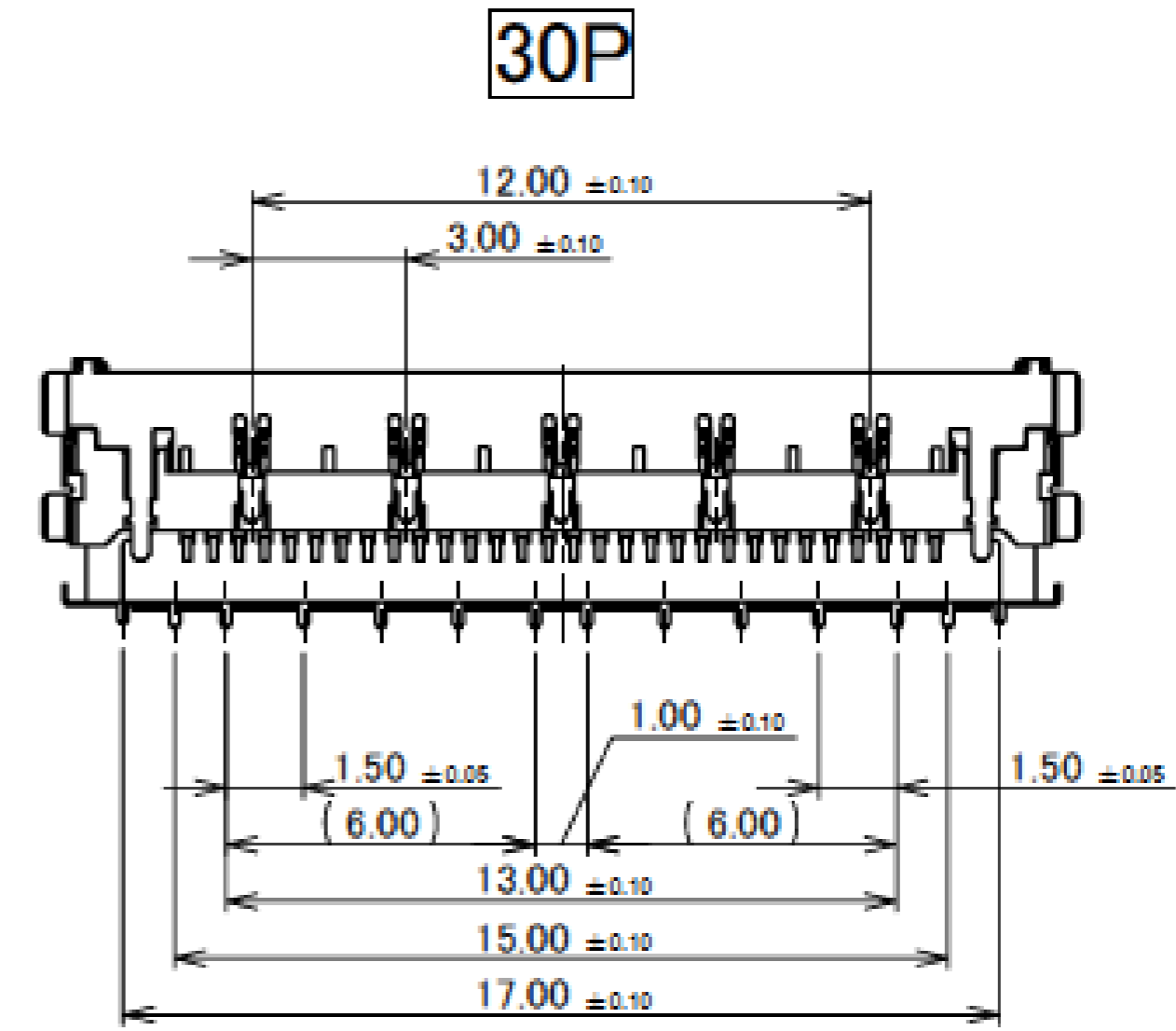
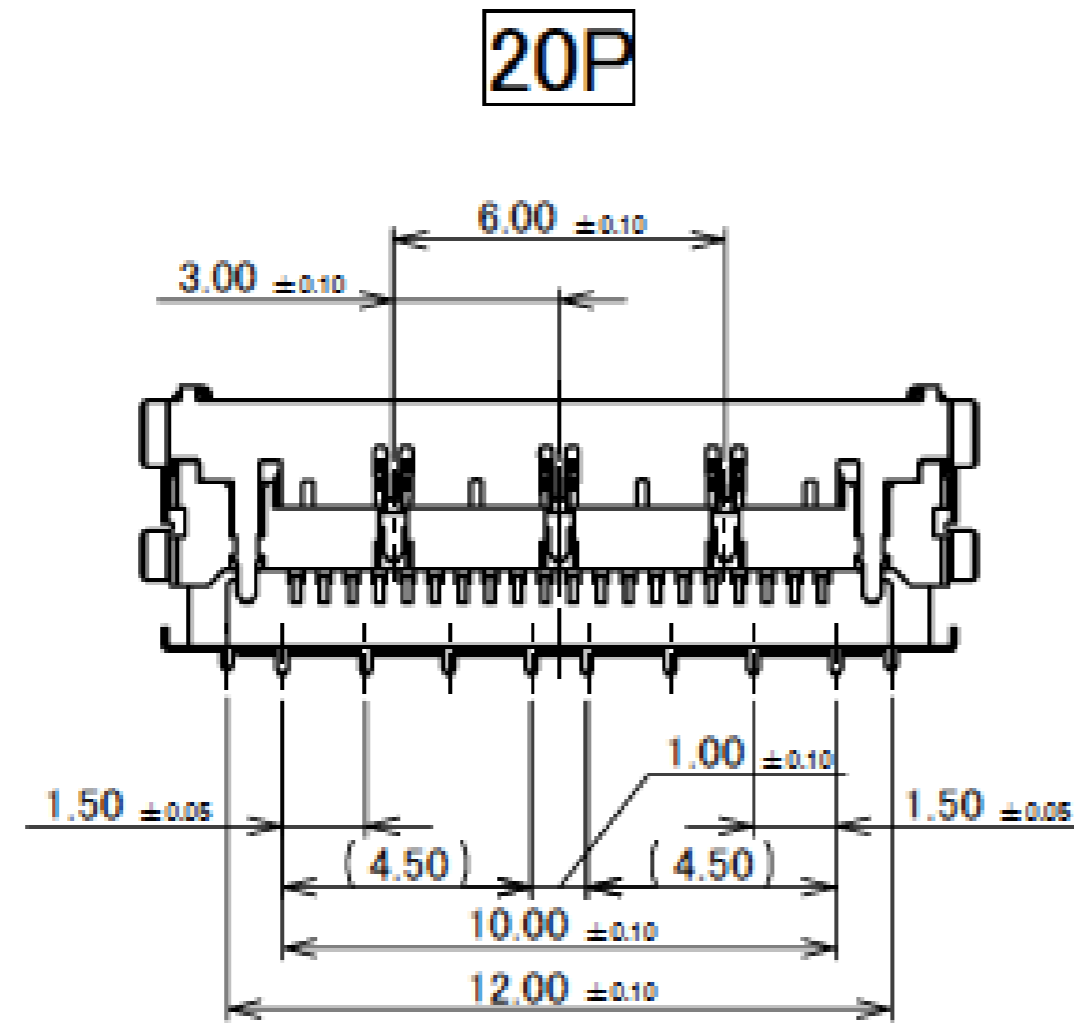

- NOTES.
1. SOLDER RESIST MUST BE APPLIED TO THIS AREA.
2. DO NOT MOUNT ANOTHER COMPONENT IN THIS AREA.

Rev.11

Rev.11

Receptacle Assembly

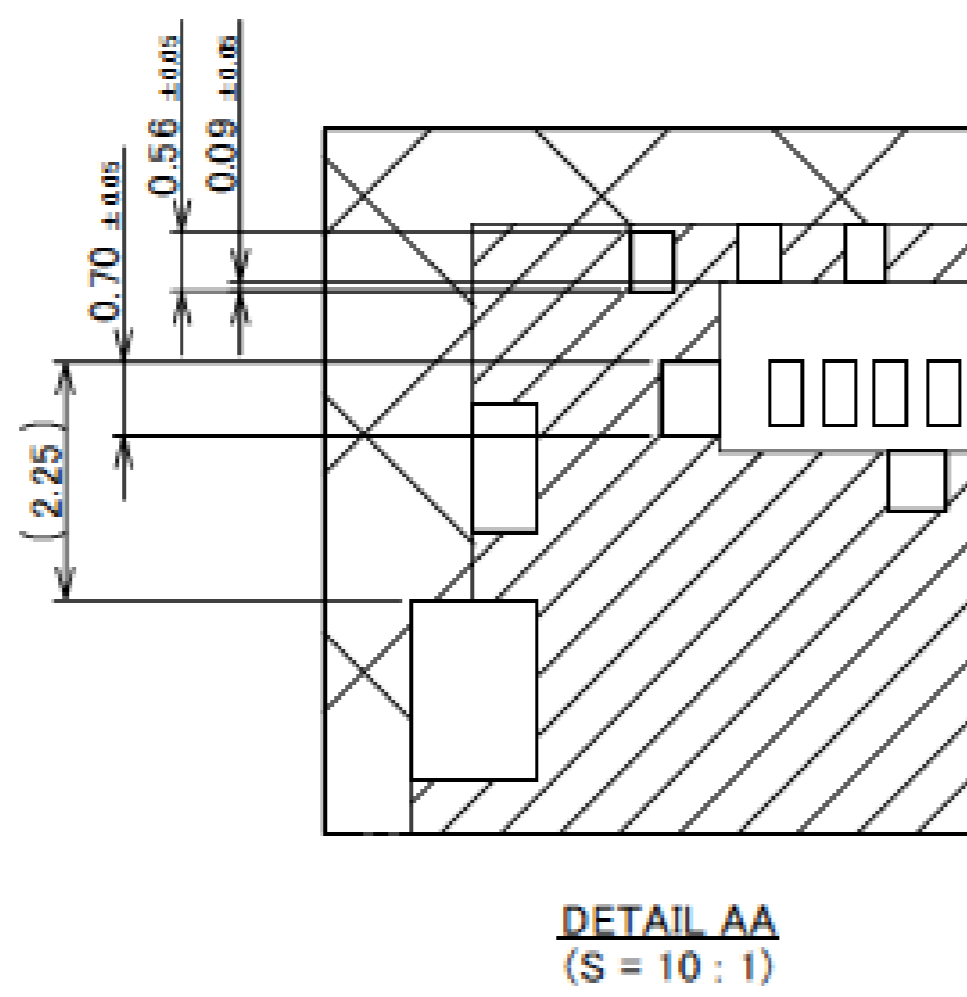
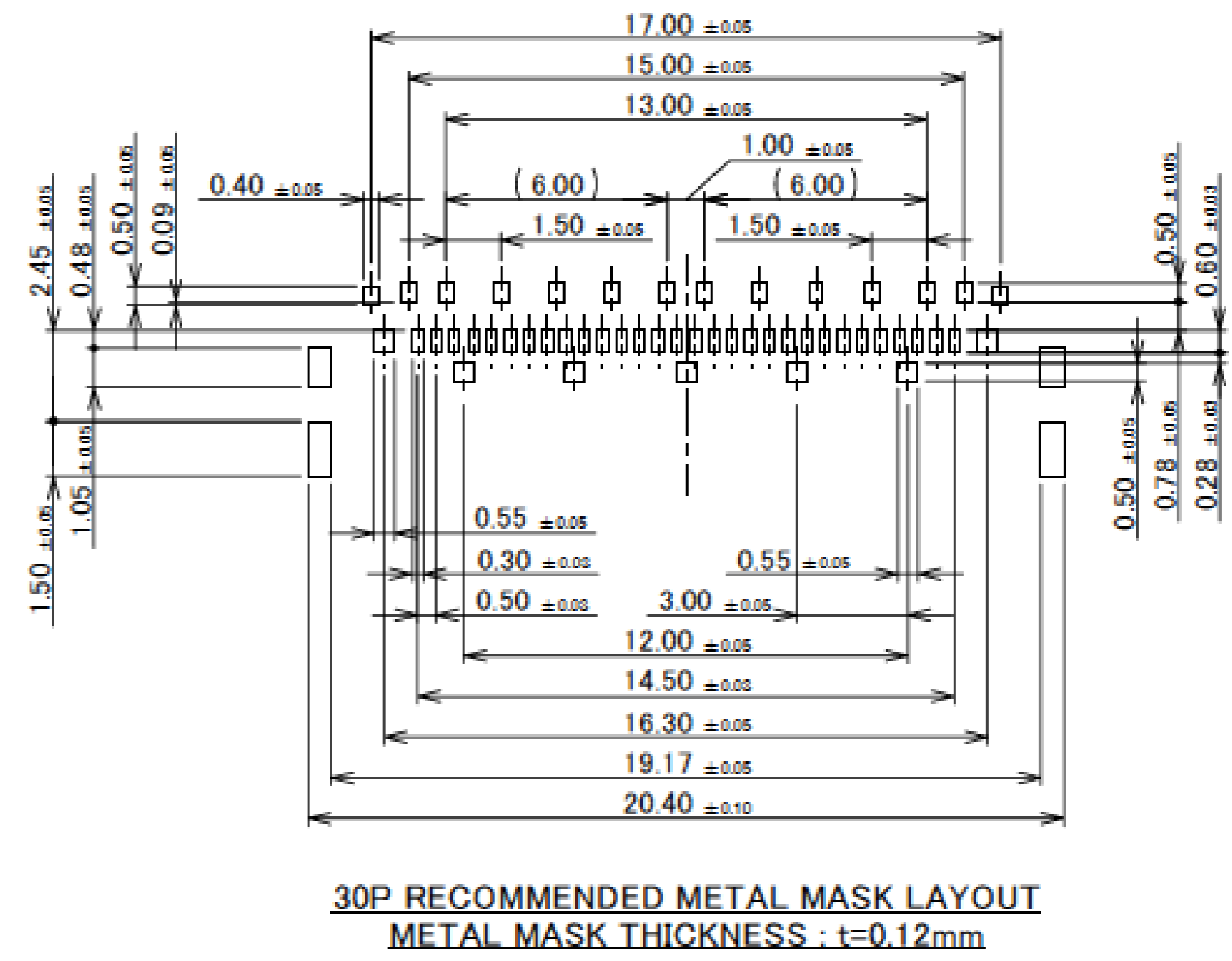
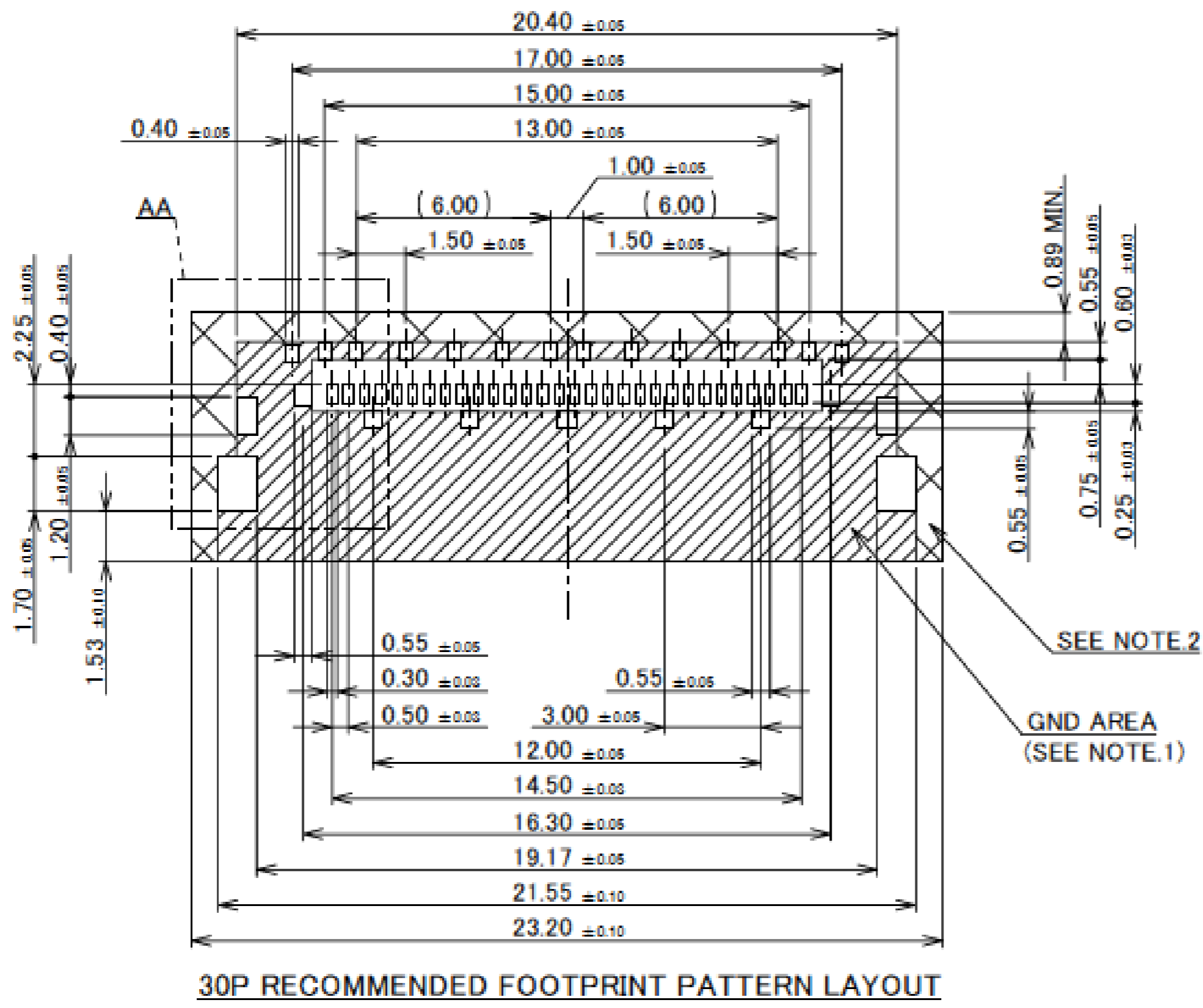

- NOTES.
1. SOLDER RESIST MUST BE APPLIED TO THIS AREA.
2. DO NOT MOUNT ANOTHER COMPONENT IN THIS AREA.

Rev.11

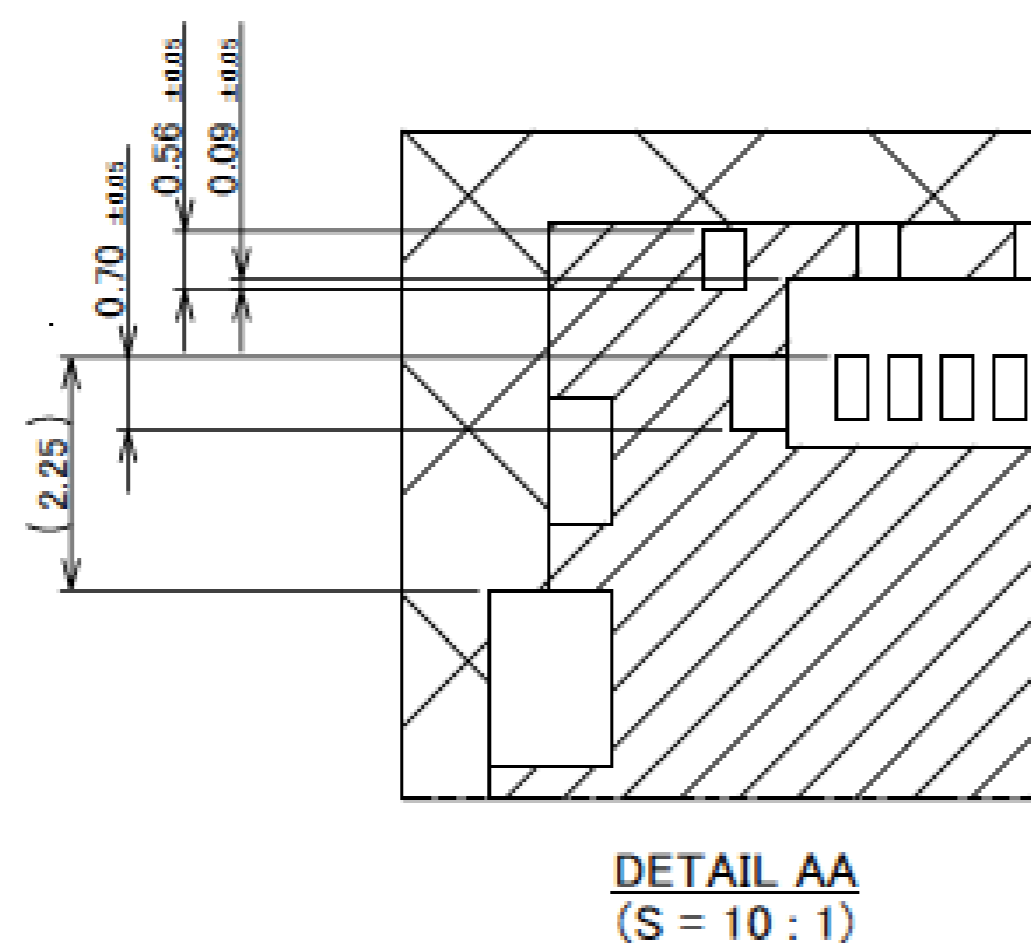
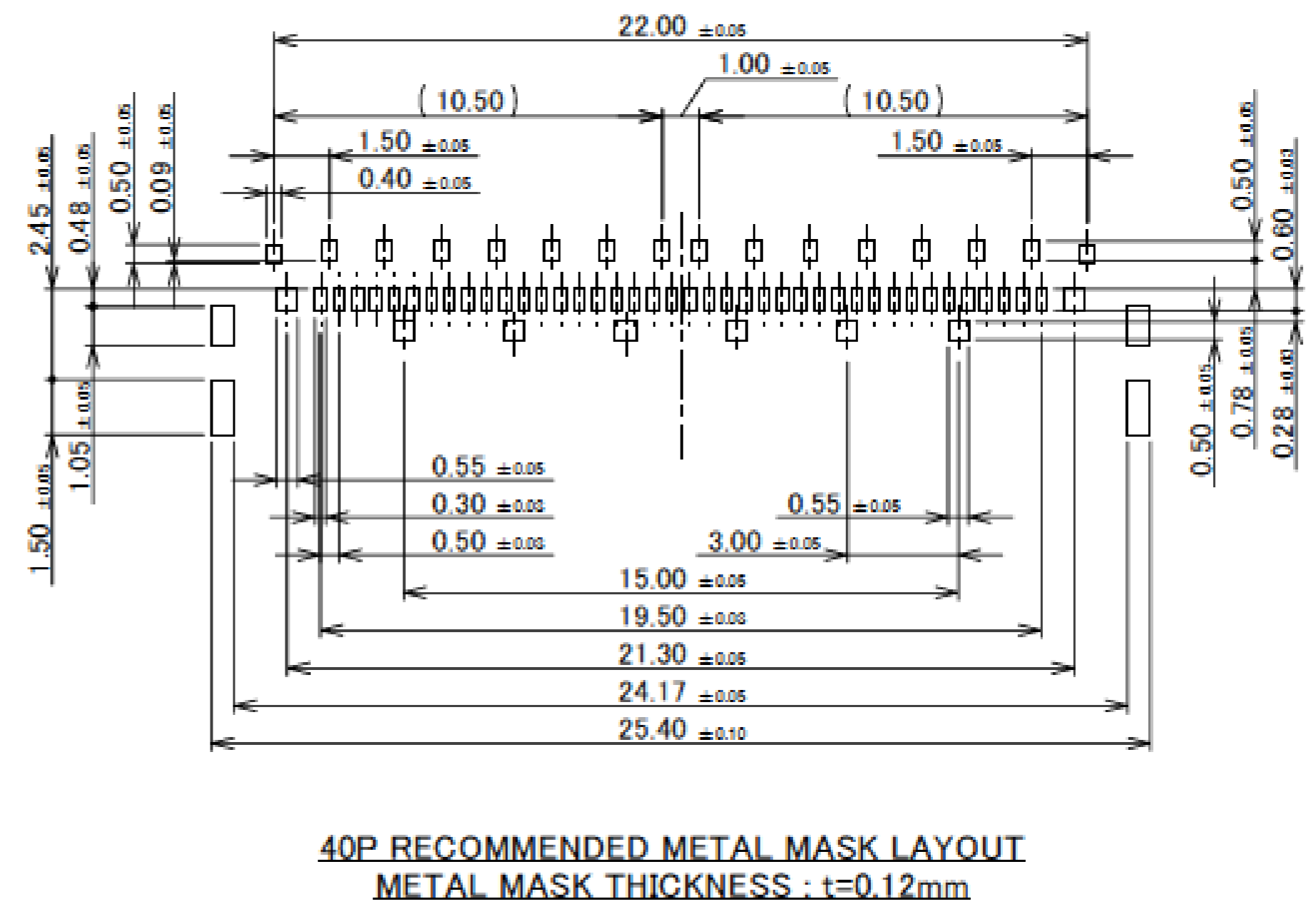
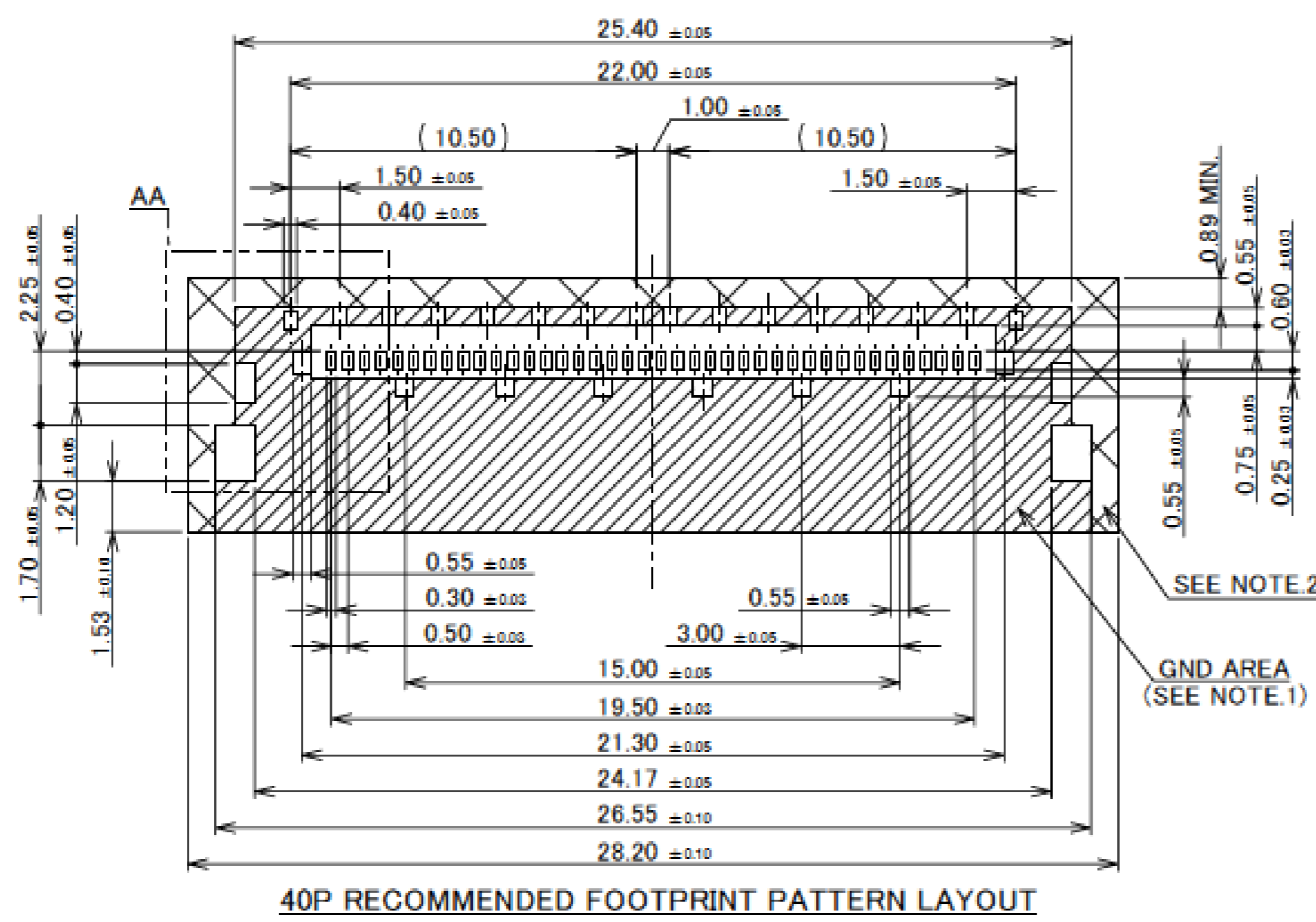

- NOTES.
1. SOLDER RESIST MUST BE APPLIED TO THIS AREA.
2. DO NOT MOUNT ANOTHER COMPONENT IN THIS AREA.

Rev.11

Receptacle Assembly

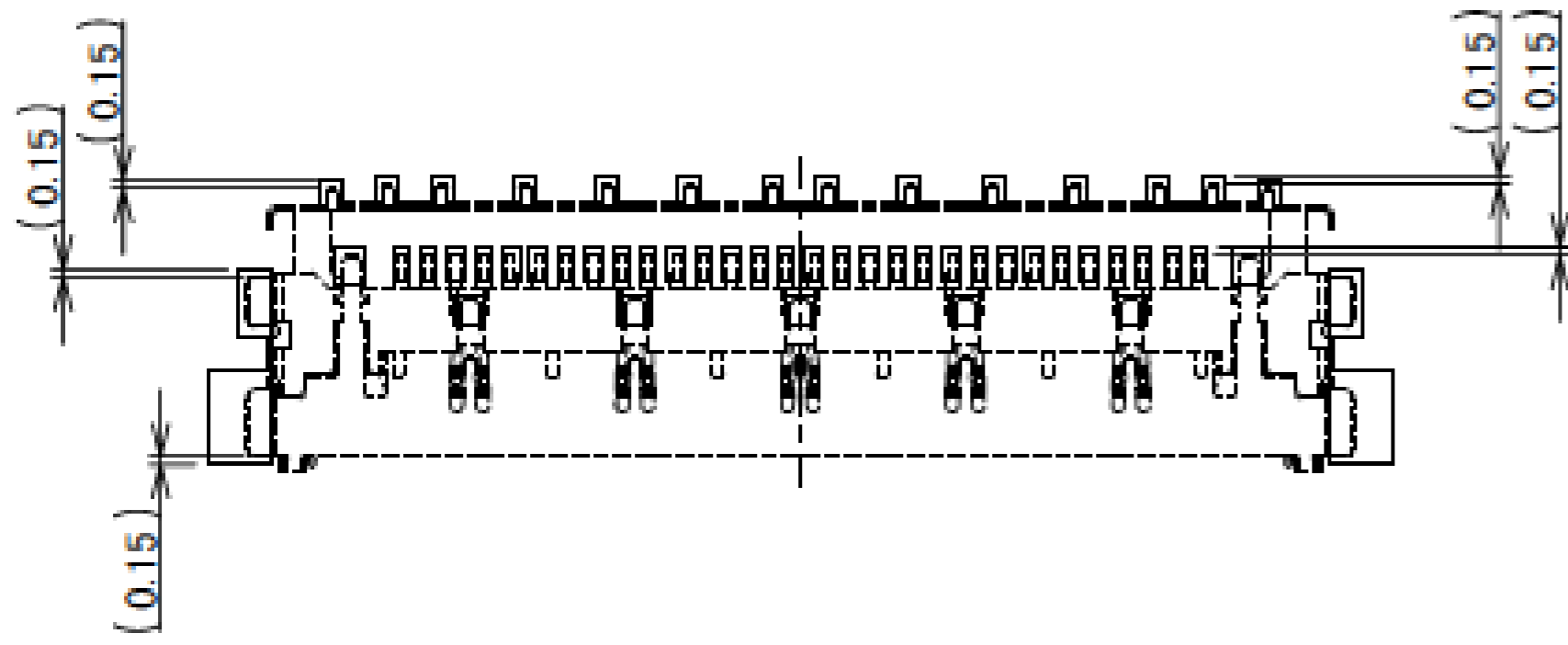

CONNECTOR ON RECOMMENDED FOOTPRINT PATTERN

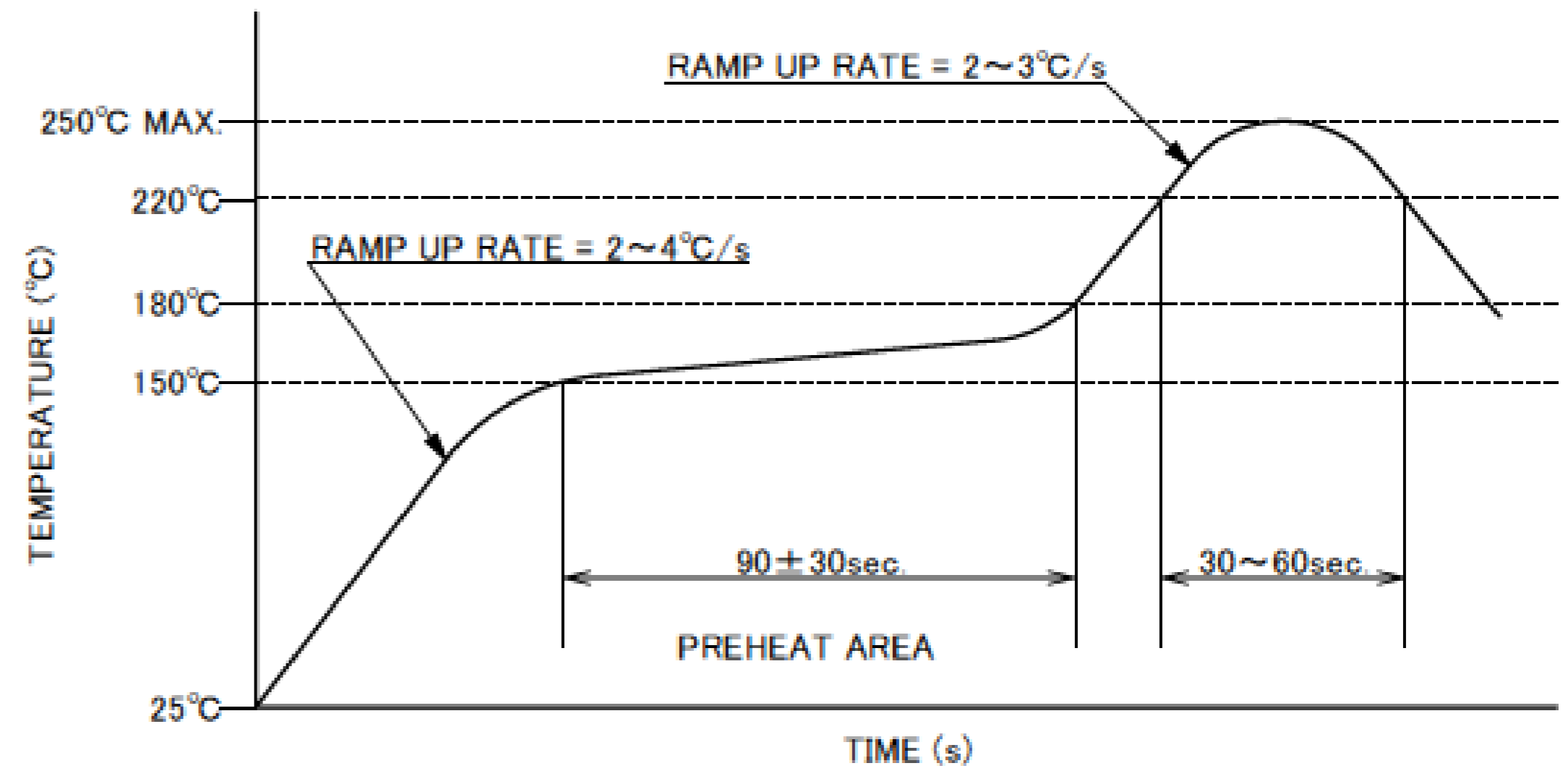

REFLOW TEMPERATURE PROFILE
SENJU METAL INDUSTRY CO., LTD. : M705-SHF(Sn96.5 Ag3.0 Cu0.5)

Rev.11

ITEMS	SPECIFICATION
APPLICABLE CABLE	MICRO-COAXIAL CABLE : AWG# 44 , 42 , 40 , 38 , 36 DISCRETE WIRE : AWG# 36 , 34 , 32 TWINAX CABLE : AWG# 40
RATING VOLTAGE	100V AC (PER CONTACT PIN) ※THIS IS THE RATED VOLTAGE OF THE CONNECTOR. PLEASE NOTE THAT THE RATED VOLTAGE MAY VARY IN THE HARNESS DEPENDING ON THE CABLES USED.
RATING AMPERAGE (FOR CONTACT)	0.1A AC/DC [AWG#44] PER CONTACT PIN/UP TO 40 CONTACTS 0.24A AC/DC [AWG#42] PER CONTACT PIN/UP TO 40 CONTACTS 0.3A AC/DC [AWG#40] PER CONTACT PIN/UP TO 40 CONTACTS 0.5A AC/DC [AWG#38] PER CONTACT PIN/UP TO 23 CONTACTS 0.8A AC/DC [AWG#36] PER CONTACT PIN/UP TO 10 CONTACTS 1.0A AC/DC [AWG#34] FOR POWER PER CONTACT/UP TO 9 CONTACTS 1.0A AC/DC [AWG#32] FOR POWER PER CONTACT/UP TO 9 CONTACTS ※TESTING BY A REAL MACHINE IS RECOMMENDED BECAUSE TEMPERATURE RISE MAY AFFECTED BY ACTUAL SITUATION
OPERATING TEMPERATURE	233~378K(-40°C~+105°C)
OPERATING HUMIDITY	85% MAX.
CONTACT RESISTANCE	INITIAL : 140mohm MAX.(AWG#32) / AFTER TEST : \triangleleft40mohm MAX. 180mohm MAX.(AWG#34) 275mohm MAX.(AWG#36) 360mohm MAX.(AWG#38) 600mohm MAX.(AWG#40) 700mohm MAX.(AWG#42) 1080mohm MAX.(AWG#44)
GROUND SHELL RESISTANCE	INITIAL : 50mohm MAX. / AFTER TEST : \triangleleft40mohm MAX.
INSULATION RESISTANCE	INITIAL : 1000Mohm MIN. / AFTER TEST : 500Mohm MIN.
DIELECTRIC WITHSTANDING VOLTAGE	AC250V 1min
DURABILITY	30 CYCLES
MATING FORCE (INITIAL / AFTER 30 CYCLES)	20P : 9.70N MAX. 30P : 14.55N MAX. 40P : 19.40N MAX.
UNMATING FORCE (INITIAL / AFTER 30 CYCLES)	20P : 2.00N MIN. 30P : 3.00N MIN. 40P : 4.00N MIN.
CABLE RETENTION FORCE	20P : 9.80N MIN. 30P : 14.70N MIN. 40P : 19.60N MIN.
PRODUCT SPECIFICATION	PRS-2398
TEST REPORT	TR-17060 (20846-0**T-01) / TR-18048 (20846-0**T-02)
INSTRUCTION MANUAL	HIM-17015
ASSEMBLY MANUAL	ASM-17005
APPEARANCE CRITERIA No.	QLS-A***

Rev.12

Custom Connectors Available

 RF Connector

MHF® series



 CABLINE® series
Micro-coaxial/Twinax/
Discrete Wire Connector

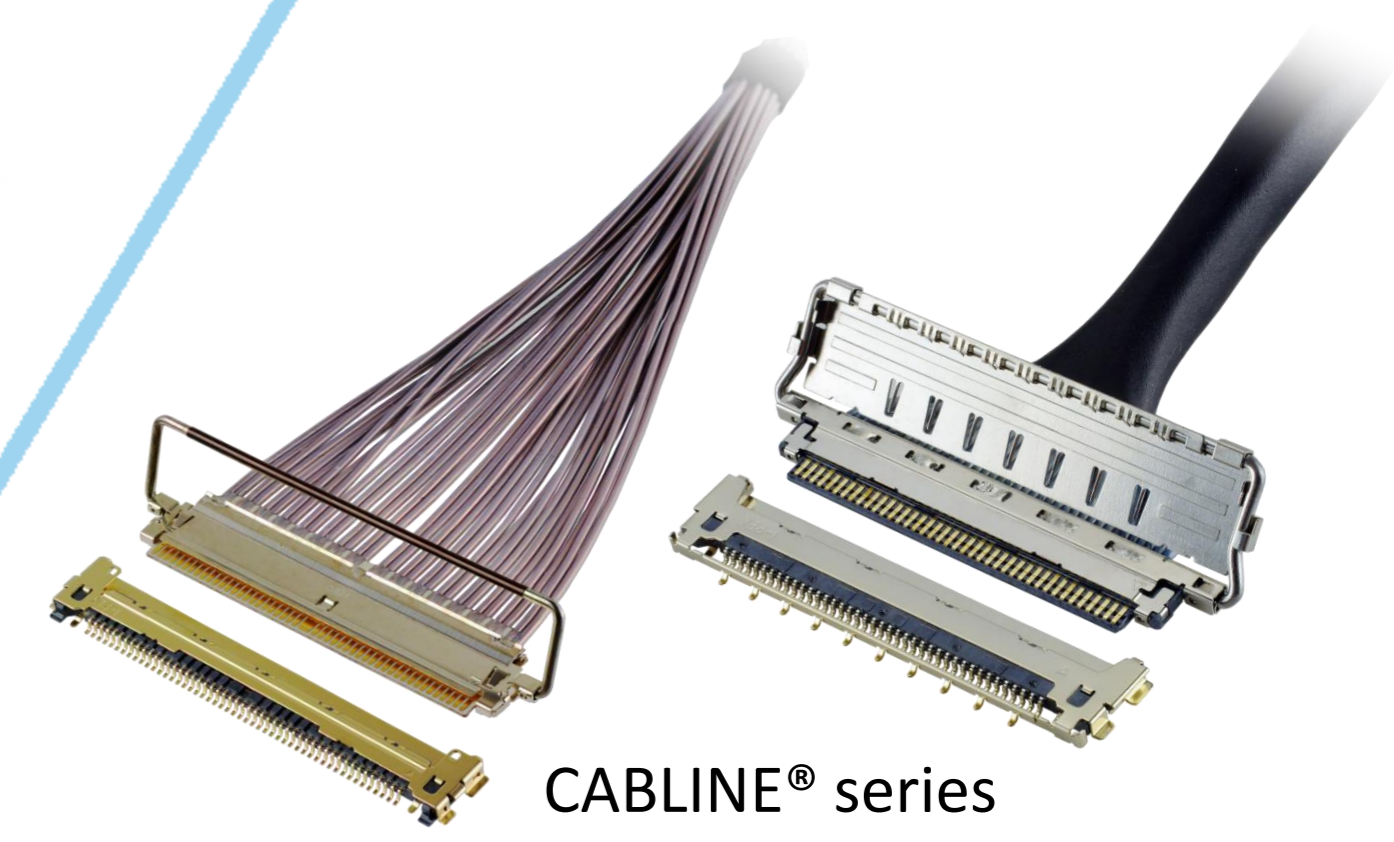

 Optical Module

LIGHTPASS® series



NOVASTACK® series

 Board-to-Board Connector

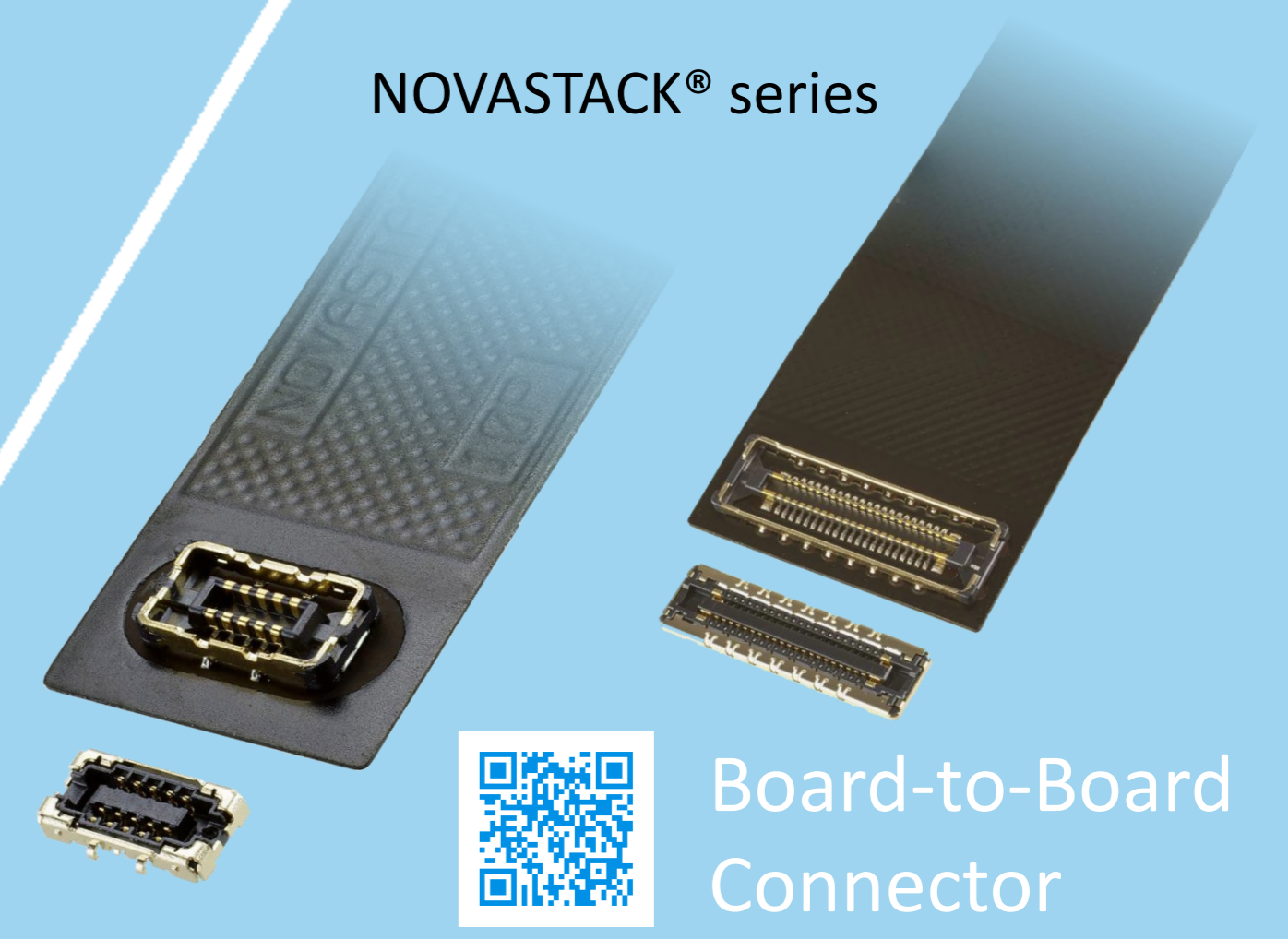

 Power Connector/
Terminal

AP series

ISH® series



MINIFLEX® series

EVAFLEX® series

 FPC FFC Connector



Inquiry



MINIDOCK® series

 I/O Connector

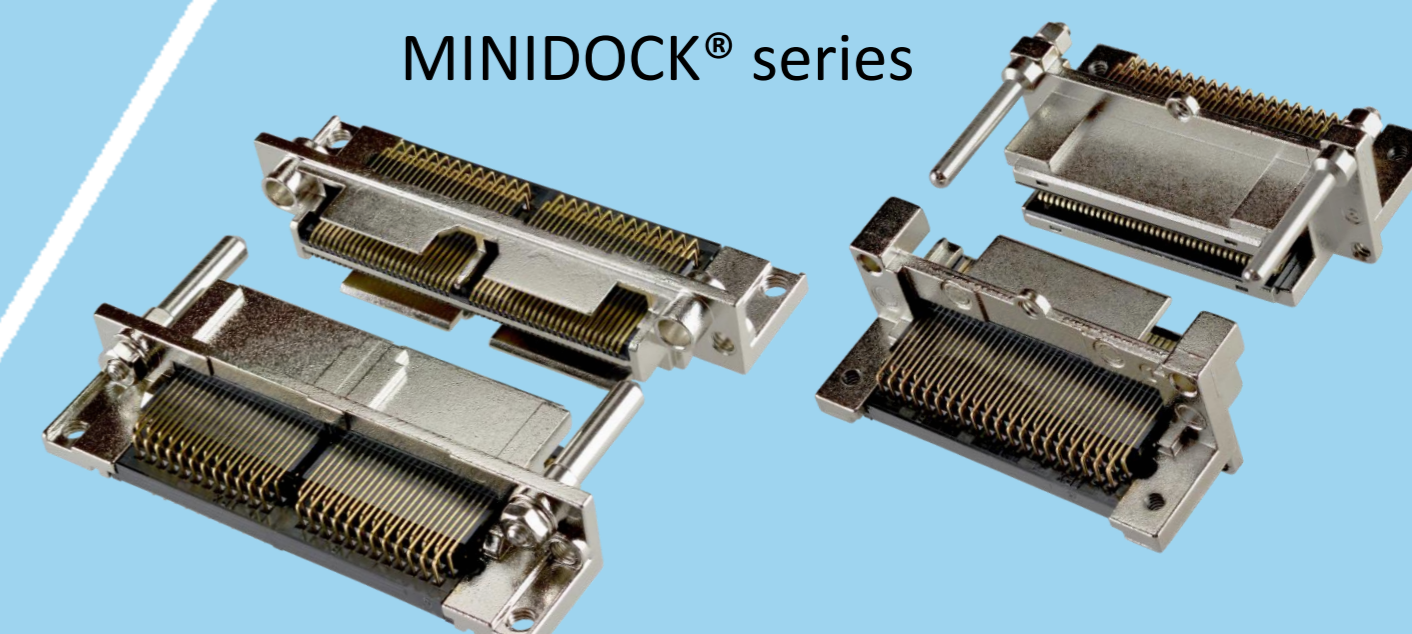

I-PEX, MHF, CABLINE, LIGHTPASS, NOVASTACK, ISH, IARPB, MINIFLEX, EVAFLEX, MINIDOCKS and ZenShield are registered trademarks of I-PEX Inc. Please note that the contents in the catalog might be changed without prior notification. I-PEX Inc. assumes no responsibility for any inaccuracies or obligation to update information on these documents. Please be sure to read and understand the latest "Precautions for Use" and "Instruction Manual" before you use our products. We shall not be responsible for any defects, damages or troubles in case you use our products without following the precautions for use. Please feel free to contact our sales representatives when you use our products for any applications that require very high reliability and safety, or that relate to human life (ex. nuclear power control, aerospace, transportation, medical equipment, safety equipment etc.).

Contact your sales representative or more detailed information.

www.i-pex.com

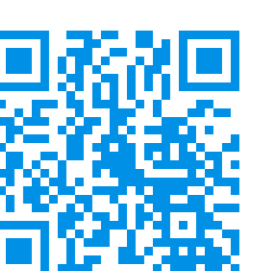

I-PEX

© I-PEX Inc. 2024
All rights reserved