

# K30L and K50L Intrinsically Safe Indicators

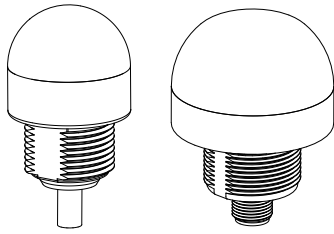

## Datasheet



- For use in hazardous areas with suitable zener barriers or galvanic isolators
- ATEX, CSA c/us, UKCA, and IECEx
- Fully sealed and rated to IP67/IP69K per DIN 40050-9
- 1-, 2-, or 3-color models available with 5 available colors

## Models

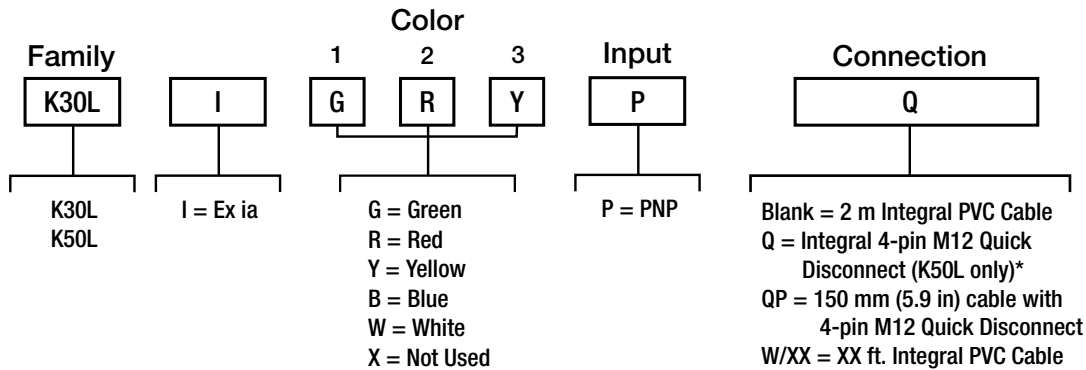

\*Models with a quick disconnect require a mating cordset

### K30L Models

Model	LED Function
K30LIGXXPQP	1 Color: Green
K30LIYXXPQP	1 Color: Yellow
K30LIRXXPQP	1 Color: Red
K30LIBXXPQP	1 Color: Blue
K30LIWXXPQP	1 Color: White
K30LIGRXPQP	2 Color: Green, Red
K30LIGYXPQP	2 Color: Green, Yellow
K30LIGYXPQP	2 Color: Red, Yellow
K30LIGRYPQP	3 Color: Green, Red, Yellow

### K50L Models

Model <sup>1</sup>	LED Function
K50LIGXXPQ	1 Color: Green
K50LIYXXPQ	1 Color: Yellow
K50LIRXXPQ	1 Color: Red
K50LIBXXPQ	1 Color: Blue
K50LIWXXPQ	1 Color: White
K50LIGRXPQ	2 Color: Green, Red
K50LIGYXPQ	2 Color: Green, Yellow
K50LIGRXPQ	2 Color: Red, Yellow
K50LIGRYPQ	3 Color: Green, Red, Yellow

<sup>1</sup> To order the 150 mm (6 in) PVC cable model with a 4-pin M12 quick disconnect, replace the suffix "Q" with "QP" in the model number. For example, K50LIGXXPQP. Models with a quick disconnect require a mating cordset.



## Installation Instructions

### Ex/HazLoc Applications

**WARNING:**

- **Explosive Atmospheres/Hazardous Locations**
- It is the user's responsibility to ensure that all local, state, and national laws, rules, codes, or regulations relating to the installation and use of this device in any particular application are satisfied. This device must be installed by a Qualified Person<sup>2</sup>, in accordance with this document and applicable regulations.

**WARNING:**

- **Explosion Hazard**
- Do not disconnect equipment unless the power has been switched off or the area is known to be non-hazardous.

**CAUTION:**

- **Electrostatic Discharge (ESD) Special Conditions for Safe Use**
- Parts of the enclosure are non-conducting and can generate an ignition-capable level of ESD.
- Clean the equipment with only a damp cloth.

### General Notes and Conditions for Use

- See Specifications and Wiring Diagrams for important information concerning entity parameters, permissible locations, electrical connections and certifications.
- In addition to the warning above concerning user responsibility, the installation must comply with the following:
  - All installations must comply with all manufacturer's instructions.
  - U.S. Installations: The relevant requirements of the National Electrical Code® (ANSI/NFPA-70 (NEC®) and when appropriate ANSI/ISA-RP12.06.01 Installation of Intrinsically Safe Systems for Hazardous (Classified) Locations.
  - Canadian Installations: The relevant requirements of the Canadian Electrical Code (CSA C22.1).
  - ATEX and IECEx Installations: The relevant requirements of EN IEC 60079-14 and applicable National regulations.
  - For quick disconnect (QD) models only: Use Banner **MQDC-4###** cordsets (see [Cordsets](#) on page 6), or suitable M12 quick disconnect cordsets with threaded retaining nut (see [Specifications](#) on page 5). The cordset must be securely fastened using the M12×1 quick disconnect retaining nut to prevent disconnection. Maximum connector torque: 6 ft·lbs.
- Do not attempt any repairs to this device; it contains no field-replaceable parts or components. Tampering and/or replacement with non-factory components may adversely affect the safe use of the system.
- Approved Apparatus entity parameters must meet the following requirements:
  - $V_{oc} \text{ or } V_t \leq V_{max}$
  - $C_a \geq C_i + C_{cable}$
  - $I_{sc} \text{ or } I_t \leq I_{max}$
  - $L_a \geq L_i + L_{cable}$
- Device and Cable Entity Parameters: See [Wiring Diagram](#) on page 3 and [Configuration](#) on page 3
- The ambient operating temperature range of the device:
  - EPL Ga & Ma:
    - Pi = 2.8W: Ta = -40 °C to +50 °C (-40 °F to +122 °F)
    - Pi = 3.4W: Ta = -40 °C to +40 °C (-40 °F to +104 °F)
  - EPL Da:
    - Pi = 2.2W: Ta = -40 °C to +50 °C (-40 °F to +122 °F)
    - Pi = 2.7W: Ta = -40 °C to +40 °C (-40 °F to +104 °F)
- For intrinsically safe installations, device must be used with certified intrinsically safe switching amplifiers and barriers (Approved Apparatus) with intrinsically safe circuits that limit supply voltage and current in the event of failures.
- Intrinsic safety ground, if required for the Associated Apparatus, shall be less than 1 ohm.
- The dust rating of enclosures/panels may be invalidated by the installation of the EZ-LIGHT(s). The installation of the EZ-LIGHT(s) in a particular enclosure/panel is subject to the evaluation/acceptance of the applicable approval agency.
- The nonconducting materials of this device may be susceptible to ignition-capable level of electrostatic charging and precautions must be taken to avoid this. The user/installer shall ensure that the equipment is not installed in a location where it may be subjected to external conditions (such as high-pressure steam) which are conducive to creating a build-up of electrostatic charges.
- Clean with a damp cloth only.
- If the equipment is likely to come into contact with aggressive substances<sup>3</sup>, then it is the responsibility of the user to take suitable precautions<sup>4</sup> that prevent it from being adversely affected, thus ensuring that the type of protection is not compromised.

<sup>2</sup> A Qualified Person is a person who, by possession of a recognized degree or certificate of professional training, or who, by extensive knowledge, training and experience, has successfully demonstrated the ability to solve problems relating to the subject matter and work.

<sup>3</sup> Aggressive substances—for example, acidic liquids or gases that may attack metals, or solvents that may affect polymeric materials.

- For indicators with multiple colors, only one color is intended to be on at a time.
- When more than one intrinsically safe supply (e.g. two or three barriers) is connected to an LED indicator (input) the combined electrical parameters of the supply must remain intrinsically safe.

## Wiring Diagram

The device is intrinsically safe ONLY when used with certified intrinsically safe switching amplifiers and barriers (Approved Apparatus) with intrinsically safe circuits.

Banner does not manufacture such devices; however, Banner applications engineers can refer you to suppliers of certified devices that will interface with the Banner device.

The user is responsible for proper installation and maintenance of this equipment, and must conform with the certification requirements relating to barriers and to maximum allowable capacitance and inductance of the field wiring. If in doubt about these requirements, Banner applications engineers can refer you to the appropriate authority.

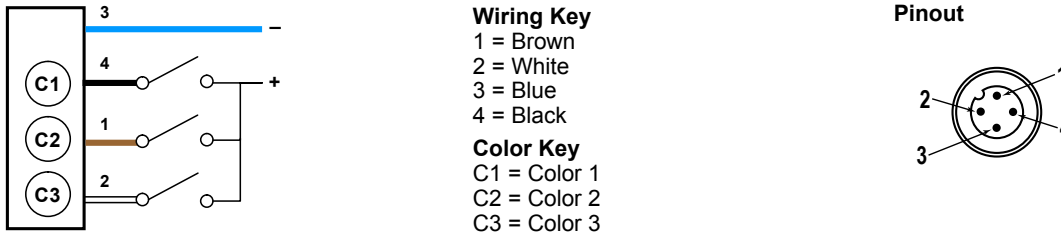

See [Configuration](#) on page 3 for hazardous area wiring and installation notes.

## Configuration

Figure 1. Control Drawing 1-Color Configuration

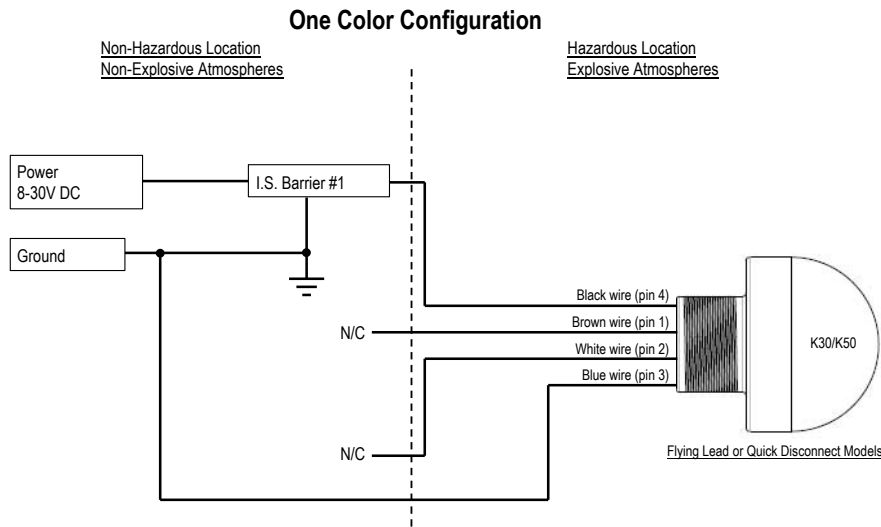

### I.S. Barrier Installation Notes

1. Safety parameters are as follows:  
 $U_i / V_{max} = 30V DC$   
 $I_i / I_{max} = 1A$   
 EPL Ga & Ma:  
 $P_i = 3.4W$  ( $T_a = -40^\circ C$  to  $+40^\circ C$ )  
 $P_i = 2.8W$  ( $T_a = -40^\circ C$  to  $+50^\circ C$ )  
 $C_i = 0$   
 $L_i = 0$   
 EPL Da:  
 $P_i = 2.7W$  ( $T_a = -40^\circ C$  to  $+40^\circ C$ )  
 $P_i = 2.2W$  ( $T_a = -40^\circ C$  to  $+50^\circ C$ )  
 $C_i = 0$   
 $L_i = 0$

2. Choose approved barriers such that the following conditions are met with all barriers combined  
 $U_i / V_{max} \geq U_o / V_{oc}$   
 $I_i / I_{max} \geq I_o / I_{sc}$   
 $P_i / P_{max} \geq P_o$   
 $C_o / C_a \geq C_i + C_{cable}$   
 $L_o / L_a \geq L_i + L_{cable}$

3. Install I.S. barriers in accordance with manufacturers instructions and local codes

4. Suggested I.S. barriers are as follows  
 MTL 7715+ (15V/100Ω)  
 MTL 7715P+ (15V/50 Ω)  
 Turck MZB15PX (15V/50 Ω)

	IIC	IIB	IIA
C <sub>cable</sub>	66nF	0.56μF	1.82μF
L <sub>cable</sub>	35μH	140μH	280μH

‡ Suitable precaution—for example, regular checks as part of routine inspections or establishing from the materials data sheet that it is resistant to specific chemicals.

Figure 2. Control Drawing 2-Color Configuration

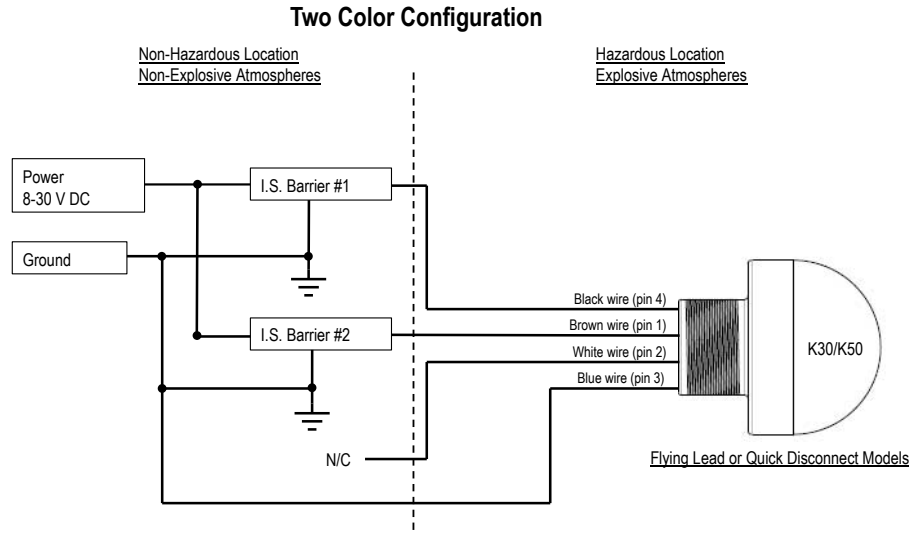

**I.S. Barrier Installation Notes**

1. Safety Parameters are as follows:  
 $U_i / V_{max} = 30V\ DC$   
 $I_i / I_{max} = 1A$   
 EPL Ga & Ma:  
 $P_i = 3.4W$  ( $T_a = -40^\circ C$  to  $+40^\circ C$ )  
 $P_i = 2.8W$  ( $T_a = -40^\circ C$  to  $+50^\circ C$ )  
 $C_i = 0$   
 $L_i = 0$   
 EPL Da:  
 $P_i = 2.7W$  ( $T_a = -40^\circ C$  to  $+40^\circ C$ )  
 $P_i = 2.2W$  ( $T_a = -40^\circ C$  to  $+50^\circ C$ )  
 $C_i = 0$   
 $L_i = 0$
2. Choose approved barriers such that the following conditions are met with all barriers combined  
 $U_i / V_{max} \geq U_o / V_{oc}$   
 $I_i / I_{max} \geq I_o / I_{sc}$   
 $P_i / P_{max} \geq P_o$   
 $C_o / C_a \geq C_i + C_{cable}$   
 $L_o / L_a \geq L_i + L_{cable}$
3. Install I.S. barriers in accordance with manufacturers instructions and local codes
4. Suggested I.S. barriers are as follows  
 MTL 7715+ (15V/100Ω)  
 MTL 7715P+ (15V/50 Ω)  
 Turck MZB15PX (15V/50 Ω)

	IIC	IIB	IIA
C <sub>cable</sub>	66nF	0.56μF	1.82μF
L <sub>cable</sub>	35μH	140μH	280μH

Figure 3. Control Drawing 3-Color Configuration

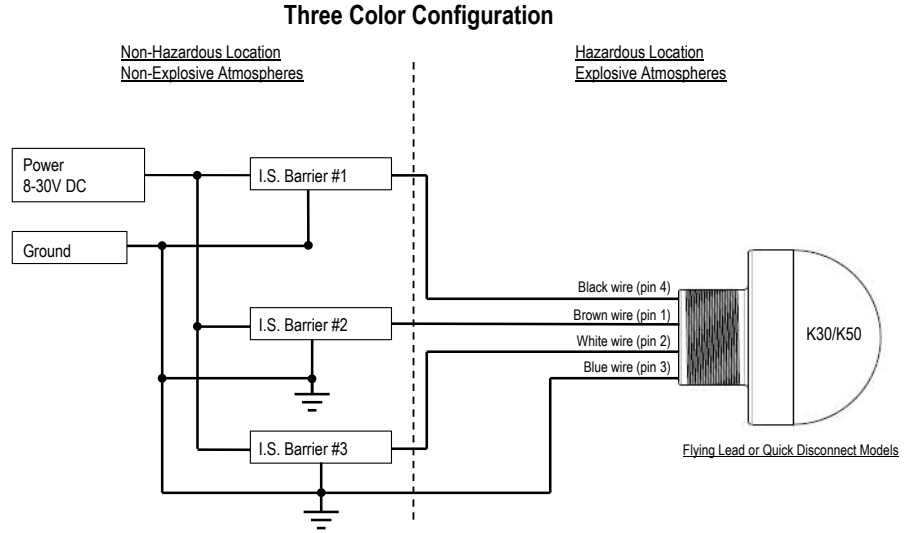

**I.S. Barrier Installation Notes**

1. Safety Parameters are as follows:  
 $U_i / V_{max} = 30V\ DC$   
 $I_i / I_{max} = 1A$   
 EPL Ga & Ma:  
 $P_i = 3.4W$  ( $T_a = -40^\circ C$  to  $+40^\circ C$ )  
 $P_i = 2.8W$  ( $T_a = -40^\circ C$  to  $+50^\circ C$ )  
 $C_i = 0$   
 $L_i = 0$   
 EPL Da:  
 $P_i = 2.7W$  ( $T_a = -40^\circ C$  to  $+40^\circ C$ )  
 $P_i = 2.2W$  ( $T_a = -40^\circ C$  to  $+50^\circ C$ )  
 $C_i = 0$   
 $L_i = 0$
2. Choose approved barriers such that the following conditions are met with all barriers combined  
 $U_i / V_{max} \geq U_o / V_{oc}$   
 $I_i / I_{max} \geq I_o / I_{sc}$   
 $P_i / P_{max} \geq P_o$   
 $C_o / C_a \geq C_i + C_{cable}$   
 $L_o / L_a \geq L_i + L_{cable}$
3. Install I.S. barriers in accordance with manufacturers instructions and local codes
4. Suggested I.S. barriers are as follows  
 MTL 7715+ (15V/100Ω)  
 MTL 7715P+ (15V/50 Ω)  
 Turck MZB15PX (15V/50 Ω)

	IIC	IIB	IIA
C <sub>cable</sub>	66nF	0.56μF	1.82μF
L <sub>cable</sub>	35μH	140μH	280μH

## Specifications

### Supply Voltage and Current

See Configuration for safety parameters

### Indicators

Entire translucent diffuser or dome provides indication. LEDs are independently selected: Green, Red, or Amber; 2 or 3 colors, depending on model. For other colors/combinations, contact Banner Engineering for availability.

### Environmental Rating

IEC IP67/IEC IP69K

### Approvals

#### CSA-c/us

Gas and Vapors: Class I Zone 0 AEx/Ex ia IIC T4 Ga / Class I Div 1 Groups ABCD  
 Dust: Class II Zone 20 AEx/Ex ia IIIC T130°C Da / Class II Div 1 Groups EFG, Class III Div 1  
 CSA 14.2679646

#### ATEX/IECEX/UKCA

Gas and Vapors: II 1 G Ex ia IIC T4 Ga (Group IIC Zone 0)  
 Dust: II 1 D Ex ia IIIC T200 130°C Da (Group IIIC Zone 20)  
 Mines: I M1 Ex ia I Ma (Methane)  
 Sira 13ATEX2058X  
 IECEX SIR 13.0020X  
 CSAE 21UKEX2681X  
 ATEX/UKCA: EN IEC 60079-0:2018 & EN 60079-11:2012  
 IECEX: IEC 60079-0:2017 Ed.7 & IEC 60079-11:2011 Ed.6

### Construction

Base: polycarbonate  
 Translucent dome: polycarbonate

### Connections

Maximum cable length 29 m per parameters list in [Figure 1](#) on page 3, [Figure 2](#) on page 4, and [Figure 3](#) on page 4.

Connecting 4-pin M12 QD Cordsets (see [Cordsets](#) on page 6):  
 Female single-ended Multiconductor cable (at minimum): UL Style 2517, 24 AWG wire, rated  $\geq 80$  °C; M12 quick disconnect connector: per IEC 61076-2-101, must have threaded M12  $\times$  1 retaining nut.

**K30:** 2 m (6.5 ft) PVC integral cable, or 150 mm (5.9 in) PVC cable with 4-pin M12 quick disconnect connector

**K50:** 4-pin M12 integral quick disconnect connector, 2 m (6.5 ft) PVC integral cable, or 150 mm (5.9 in) PVC cable with 4-pin M12 quick disconnect connector

### Operating Conditions

EPL Ga & Ma:

- Pi = 2.8W: Ta = -40 °C to +50 °C (-40 °F to +122 °F)
- Pi = 3.4W: Ta = -40 °C to +40 °C (-40 °F to +104 °F)

EPL Da:

- Pi = 2.2W: Ta = -40 °C to +50 °C (-40 °F to +122 °F)
- Pi = 2.7W: Ta = -40 °C to +40 °C (-40 °F to +104 °F)

See [Figure 1](#) on page 3, [Figure 2](#) on page 4, and [Figure 3](#) on page 4

### Certifications



**Banner Engineering Europe**  
 Park Lane, Culliganlaan 2F  
 bus 3, 1831 Diegem,  
 BELGIUM

**Turck Banner LTD**  
 Blenheim House, Blenheim  
 Court, Wickford, Essex  
 SS11 8YT, Great Britain

IEC IECEX SIR 13.0020X  
 ATEX Sira 13ATEX2058X  
 CSAE 21UKEX2681X  
 CSA CoC 2679646

Figure 4. K30L Product Label



Figure 5. K50L Product Label



## Dimensions

All measurements are listed in millimeters [inches], unless noted otherwise.

### K30L Cabled Models

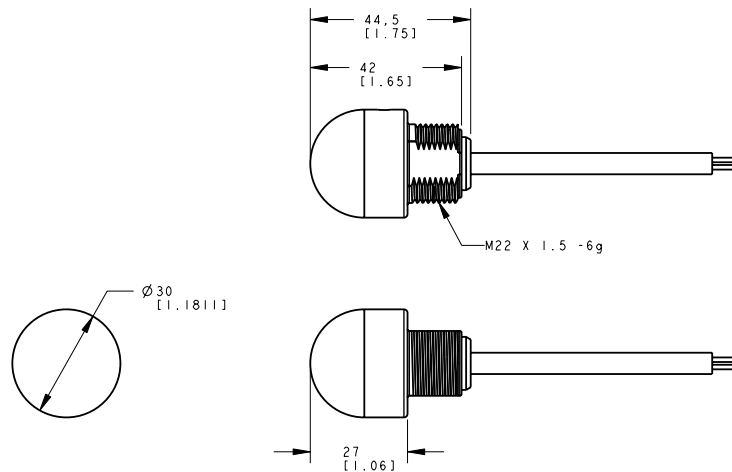

**K50L Quick Disconnect Models**

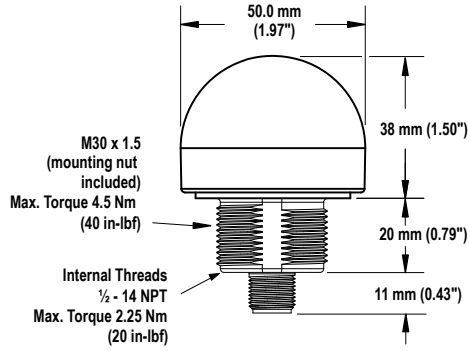

**K50L Cabled Models**

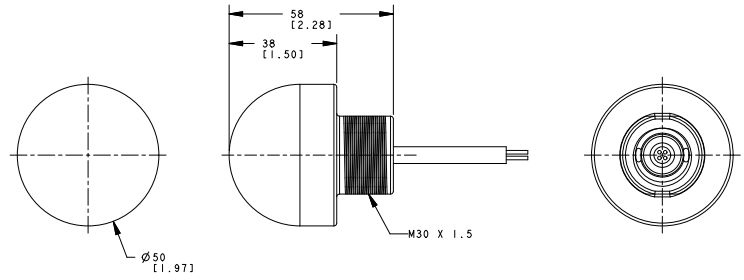

Accessories

Cordsets

4-Pin Threaded M12 Cordsets—Single Ended				
Model	Length	Style	Dimensions	Pinout (Female)
MQDC-406	2 m (6.56 ft)	Straight		
MQDC-415	5 m (16.4 ft)			
MQDC-430	9 m (29.5 ft)			
MQDC-450	15 m (49.2 ft)			
MQDC-406RA	2 m (6.56 ft)	Right-Angle		
MQDC-415RA	5 m (16.4 ft)			
MQDC-430RA	9 m (29.5 ft)			
MQDC-450RA	15 m (49.2 ft)			

Banner Engineering Corp. Limited Warranty

Banner Engineering Corp. warrants its products to be free from defects in material and workmanship for one year following the date of shipment. Banner Engineering Corp. will repair or replace, free of charge, any product of its manufacture which, at the time it is returned to the factory, is found to have been defective during the warranty period. This warranty does not cover damage or liability for misuse, abuse, or the improper application or installation of the Banner product.

**THIS LIMITED WARRANTY IS EXCLUSIVE AND IN LIEU OF ALL OTHER WARRANTIES WHETHER EXPRESS OR IMPLIED (INCLUDING, WITHOUT LIMITATION, ANY WARRANTY OF MERCHANTABILITY OR FITNESS FOR A PARTICULAR PURPOSE), AND WHETHER ARISING UNDER COURSE OF PERFORMANCE, COURSE OF DEALING OR TRADE USAGE.**

This Warranty is exclusive and limited to repair or, at the discretion of Banner Engineering Corp., replacement. **IN NO EVENT SHALL BANNER ENGINEERING CORP. BE LIABLE TO BUYER OR ANY OTHER PERSON OR ENTITY FOR ANY EXTRA COSTS, EXPENSES, LOSSES, LOSS OF PROFITS, OR ANY INCIDENTAL, CONSEQUENTIAL OR SPECIAL DAMAGES RESULTING FROM ANY PRODUCT DEFECT OR FROM THE USE OR INABILITY TO USE THE PRODUCT, WHETHER ARISING IN CONTRACT OR WARRANTY, STATUTE, TORT, STRICT LIABILITY, NEGLIGENCE, OR OTHERWISE.**

Banner Engineering Corp. reserves the right to change, modify or improve the design of the product without assuming any obligations or liabilities relating to any product previously manufactured by Banner Engineering Corp. Any misuse, abuse, or improper application or installation of this product or use of the product for personal protection applications when the product is identified as not intended for such purposes will void the product warranty. Any modifications to this product without prior express approval by Banner Engineering Corp will void the product warranties. All specifications published in this document are subject to change; Banner reserves the right to modify product specifications or update documentation at any time. Specifications and product information in English supersede that which is provided in any other language. For the most recent version of any documentation, refer to: [www.bannerengineering.com](http://www.bannerengineering.com).

For patent information, see [www.bannerengineering.com/patents](http://www.bannerengineering.com/patents).