

HCV-E Electrical level indicators

with MIN level electrical sensor, transparent technopolymer



METRIC

- 1
- 2
- 3
- 4
- 5
- 6
- 7
- 8
- 9
- 10
- 11
- 12
- 13
- 14
- 15
- 16
- 17
- 18
- 19

MATERIAL

Transparent polyamide based (PA-T) technopolymer. Highly resistant to shocks, solvents, oils with additives, aliphatic and aromatic hydrocarbons, petrol, naphtha, phosphoric esters.

Avoid contact with alcohol or detergents containing alcohol.

SCREWS, NUTS AND WASHERS

Zinc-plated steel.

PACKING RINGS

Step-shaped for the seal on the reservoir walls and NBR synthetic rubber O-ring screw underhead.

Suggested roughness of the packing ring application surface $Ra = 3 \mu m$.

FLOAT

Glass-fibre reinforced polyamide based (PA) technopolymer, black colour, with a built-in magnetic element to activate the electric contact when the float reaches the contact threshold indicated in the drawing (data referred to mineral oil type CB68, according to ISO 3498, temperature 23°C).

Floating is ensured by fluids with densities higher than 800 kg/m3.

BRACKET WITH MALE CONNECTOR

Perfectly watertight, incorporating the relay (reed) with two output conductors (NO and NC version) or three conductors (SW version).

- DIN 43650 C connector in glass-fibre reinforced polyamide based (PA) technopolymer, black colour.

- 4-pole M12x1 connector, with threading in glass-fibre reinforced polyamide based (PA) technopolymer certified self-extinguishing UL-94-V0, black colour, matte finish.

For a correct assembly see Warnings (on page 1227).

FEMALE CONNECTOR (DIN 43650 C)

With built-in cable gland and contact holder. Front or axial output (high or low) ensuring protection against water sprays (protection class IP 65 according to table EN 60529 on page A-19).

CONTRAST SCREEN

White lacquered aluminium. The housing, in the appropriate external rear slot, guarantees the best protection from direct contact with fluid.

It can be taken out from the inclined side, before assembly to allow the insertion of level lines or words.

STANDARD EXECUTIONS

See configuration table.

MAXIMUM CONTINUOUS WORKING TEMPERATURE

90°C (with oil).

TECHNICAL DATA

In laboratory tests carried out with mineral oil type CB68 (according to ISO 3498) at 23°C for a limited period of time, the weld stood up to: 18 bar (HCV.76), 18 bar (HCV.127) and 12 bar (HCV.254).

For use with other fluids and under different pressure and temperature conditions, please contact ELESA Technical Department.

In any case we suggest to verify the suitability of the product under the actual working conditions.

SPECIAL EXECUTIONS ON REQUEST

- Level indicators with stainless steel screws, nuts and washers.
- Level indicators HCV.76 with screws M12.
- Level indicators for use with fluids containing alcohol.
- UV resistant transparent technopolymer level indicators.

ACCESSORIES ON REQUEST

FC-M12x1: extensions with 4 pole M12 female axial connector.



ELESA Original design

FEATURES AND PERFORMANCES

The HCV-E level indicators, in addition to the visual level indicator, also provide an electrical signal when the minimum fluid level value is reached.

The lateral connector output allows the level of intervention of the sensor to be minimised.

Ultrasound welding to guarantee a perfect seal.

Maximum fluid level visibility even from side positions.

Lens effect for a better visibility of the fluid level.

In case of use of an extension with angled connector, the direction of the cable output is shown in Fig.1..

Fig.1
HCV-E-AX-KN

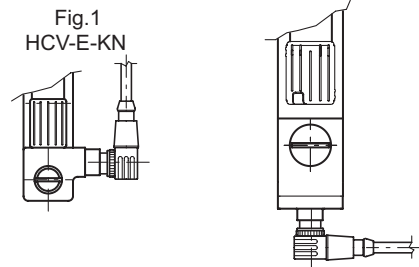

FUNCTIONING OF THE SENSORS

- NO: the electrical contact closes on reaching the minimum level.
- NC: the electrical contact is opened when it reaches the minimum level.
- SW (change-over electrical contact): the electrical contact switches between the two terminals.

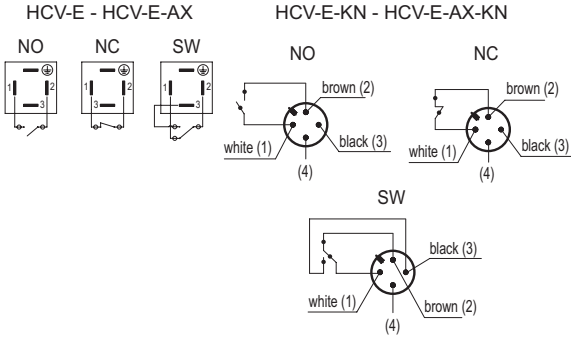

*The colours refer to the use of the FC M12x1 extension

FEMALE CONNECTOR ASSEMBLY INSTRUCTIONS

1. Remove the connector from the indicator by unscrewing the set screw placed on the connector, take the contact holders out and loosen the cable gland.
2. Slip on the cable into the connector (standard connector) and connect the wires to the terminals 1 and 2 (NO and NC version) or 1,2 and 3 (SW version) of the contact holder.
3. Assemble by pressing the contact holder into the connector in the required position.
4. Screw the connectors to the indicator and then tighten the cable glands.

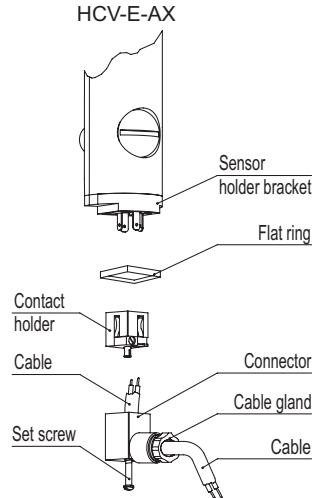
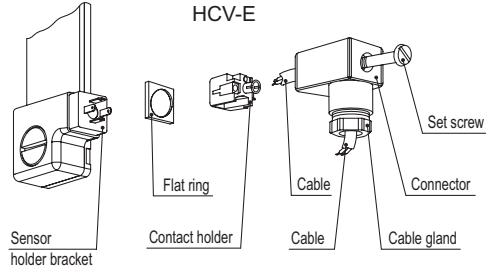

Electrical features	MIN level sensor	
Power supply	AC/DC	
Electric contacts	NO normally open NC normally closed SW change-over contact	
Maximum applicable voltage	NO: 140 Vac, 200 Vdc	DIN 43650 C
	NC: 140Vac, 150 Vdc SW: 140Vac, 150 Vdc 30 Vac, 30Vdc	
Voltage range (Type KN)	<30 Vac, <30Vdc	
Maximum switching current	1 A	
Maximum current	NO: 1.2A	
	NC: 2A	
	SW: 2A	
Maximum commutable power	NO: 10 Va	
	NC: 20 Va	
	SW: 20 Va	
Cable gland (only HCV-E - HCV-E-AX)	Pg 7 (for cables in sheath with Ø 6 or 7 mm)	
Conductors cross-section (only HCV-E - HCV-E-AX)	Max. 1.5 mm ²	
Connector (only HCV-E-KN - HCV-E-AX)	M12x1	
Do not mount this indicator in proximity to magnetic fields.	Do not mount this indicator in proximity to magnetic fields.	

TABLE FOR STANDARD EXECUTIONS SET-UP

	HCV.	-	76	-	E	-	NO	-	M10	-	KN
			①		②		③		④		⑤
① Centre distance (f)	76						76 mm				
	127						127 mm				
	254						254 mm				
② Sensor position	E						Lateral				
	E-AX						Axial (for execution 127 in paragraph 1).				
③ Electrical contact	NO						Electric contact normally open that closes when the minimum level is reached.				
	NC						Electric contact normally closed that opens when the minimum level is reached.				
	SW						Electrical exchange contact that switches between the two terminals.				
④ Screw threading	M10						M10 (for execution 76 in paragraph 1).				
	M12						M12				
⑤ Connector							DIN 43650 C, adjustable front or side output.				
	KN						4-pole male M12x1				

VITON® Registered trademark by DuPont Dow Elastomers.

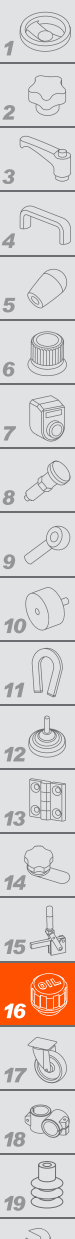

- 1
- 2
- 3
- 4
- 5
- 6
- 7
- 8
- 9
- 10
- 11
- 12
- 13
- 14
- 15
- 16
- 17
- 18
- 19

HCV-E

HCV-E-KN

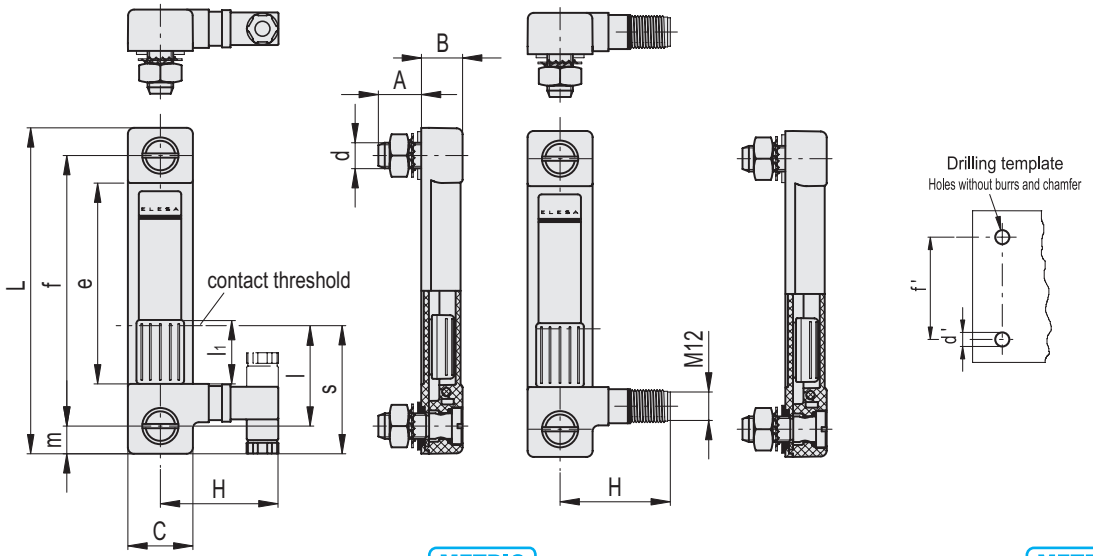

METRIC

METRIC

HCV-E															
f	d	A	B	C	H	L	e	l	l1	m	s	d'-0.2	f±0.2	C#	Δ
76	M10	20	19.5	30.5	55	102	43.5	40	20	13	53	10.5	76	12	133
127	M12	20	19.5	30.5	55	153	97	50	30	13	63	12.5	127	12	153
254	M12	20	19.5	30.5	55	280	224	50	30	13	63	12.5	254	12	180

HCV-E-KN															
f	d	A	B	C	H	L	e	l	l1	m	s	d'-0.2	f±0.2	C#	Δ
76	M10	20	19.5	30.5	47	102	43.5	40	20	13	53	10.5	76	12	133
127	M12	20	19.5	30.5	47	153	97	50	30	13	63	12.5	127	12	153
254	M12	20	19.5	30.5	47	280	224	50	30	13	63	12.5	254	12	180

HCV-E-AX

HCV-E-AX-KN

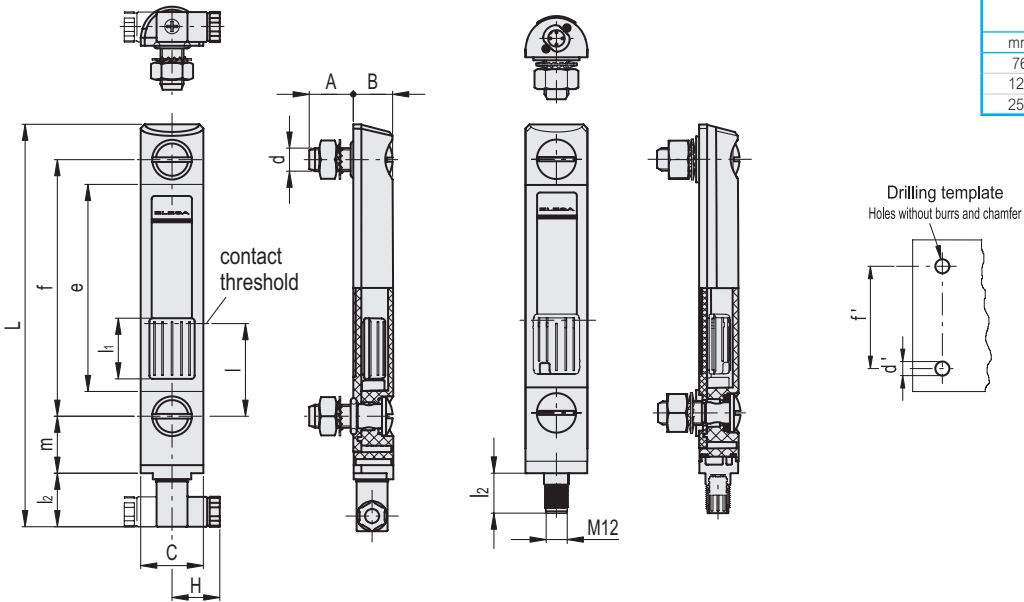

Conversion Table	
1 mm = 0.039 inch	
f	
mm	inch
76	2.96
127	4.95
254	9.91

METRIC

METRIC

HCV-E-AX															
f	d	A	B	C	H	L	e	l	l1	l2	m	d'-0.2	f±0.2	C#	Δ
127	M12	21.8	20	31	25.5	201.5	97	50	30	29	28	12.5	127	12	223

HCV-E-AX-KN														
f	d	A	B	C	L	e	l	l1	l2	m	d'-0.2	f±0.2	C#	Δ
127	M12	21.8	20	31	194.5	97	50	30	20	30	12.5	127	12	223

Accessories for hydraulic systems

3 # Maximum tightening torque.