

# EPC2221 – Automotive 100 V (D-S) Enhancement Mode Power Transistor

$R_{DS(on)}$ , 58 mΩ max

$I_D$ , 5 A

AEC-Q101

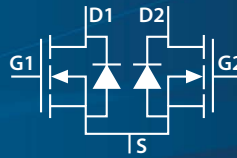

Halogen-Free

Revised April 4, 2022

The EPC2221 is a common source dual eGaN FET suitable for multi-channel lidar applications up to 20 Apk per channel. The low inductance and capacitance allow fast switching (100 MHz) and narrow pulse widths (2 ns) for high resolution and high efficiency. Additionally, the ultra-small size reduces PCB cost and total solution size. Gallium nitride's exceptionally high electron mobility and low temperature coefficient allows very low  $R_{DS(on)}$ , while its lateral device structure and majority carrier diode provide exceptionally low  $Q_G$  and zero  $Q_{RR}$ . The end result is a device that can handle tasks where very high switching frequency, and low on-time are beneficial as well as those where on-state losses dominate.

## APPLICATION NOTES:

- Easy-to-use and reliable gate, Gate Drive ON = 5 V typical, OFF = 0 V (negative voltage not needed)
- Top of FET is electrically connected to source

Questions:  
Ask a GaN  
Expert



## Maximum Ratings

PARAMETER		VALUE	UNIT
$V_{DS}$	Drain-to-Source Voltage (Continuous)	100	V
	Drain-to-Source Voltage (up to 10,000 5 ms pulses at 150°C)	120	
$I_D$	Continuous ( $T_A = 25^\circ\text{C}$ )	5	A
	Pulsed (25°C, $T_{PULSE} = 300 \mu\text{s}$ )	20	
$V_{GS}$	Gate-to-Source Voltage	6	V
	Gate-to-Source Voltage	-4	
$T_J$	Operating Temperature	-40 to 150	°C
$T_{STG}$	Storage Temperature	-40 to 150	

## Thermal Characteristics \*

PARAMETER		TYP	UNIT
$R_{\theta JC}$	Thermal Resistance, Junction-to-Case (Case TOP)	2.2	°C/W
$R_{\theta JB}$	Thermal Resistance, Junction-to-Board (Case BOTTOM)	8.7	
$R_{\theta JA\_JEDEC}$	Thermal Resistance, Junction-to-Ambient (using JEDEC 51-2 PCB)	99	
$R_{\theta JA\_EVB}$	Thermal Resistance, Junction-to-Ambient (using EPC99012 EVB)	55	

\* Thermal resistances are calculated based on the total power dissipated by the two FETs. For example, if power P is simultaneously dissipated in each FET, then the total power dissipated is 2P and the maximum junction temperature is  $T_A + R_{th} \cdot 2P$ .

## Static Characteristics ( $T_J = 25^\circ\text{C}$ unless otherwise stated)

PARAMETER		TEST CONDITIONS	MIN	TYP	MAX	UNIT
$BV_{DSS}$	Drain-to-Source Voltage	$V_{GS} = 0\text{ V}, I_D = 70 \mu\text{A}$	100			V
$I_{DSS}$	Drain-Source Leakage	$V_{DS} = 100\text{ V}, V_{GS} = 0\text{ V}$		3	70	$\mu\text{A}$
$I_{GSS}$	Gate-to-Source Forward Leakage	$V_{GS} = 6\text{ V}$		0.003	1	mA
	Gate-to-Source Forward Leakage#	$V_{GS} = 6\text{ V}, T_J = 125^\circ\text{C}$		0.1	2	mA
	Gate-to-Source Reverse Leakage	$V_{GS} = -4\text{ V}$		3	70	$\mu\text{A}$
$V_{GS(TH)}$	Gate Threshold Voltage	$V_{DS} = V_{GS}, I_D = 0.7\text{ mA}$	0.7	1.2	2.5	V
$R_{DS(on)}$	Drain-Source On Resistance	$V_{GS} = 5\text{ V}, I_D = 4\text{ A}$		40	58	mΩ
$V_{SD}$	Source-Drain Forward Voltage#	$I_S = 0.5\text{ A}, V_{GS} = 0\text{ V}$		1.5		V

# Defined by design. Not subject to production test.

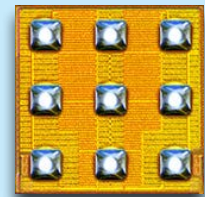

Die Size: 1.35 x 1.35 mm

EPC2221 eGaN® FETs are supplied only in passivated die form with solder bumps

## Features

- Dual eGaN FET, common source
- Low capacitance, low inductance
- Ultra-fast switching
- Narrow pulse-width capability

## Applications

- Automotive lidar/ToF
- High-frequency DC-DC
- Wireless power

## Benefits

- High resolution and efficiency in lidar Applications
- Ultra-small footprint
- Ultra high Efficiency
- No reverse recovery
- Ultra low  $Q_G$

Scan QR code or click link below for more information including reliability reports, device models, demo boards!



<https://l.ead.me/EPC2221>

Dynamic Characteristics\* (T<sub>J</sub> = 25°C unless otherwise stated)

PARAMETER		TEST CONDITIONS	MIN	TYP	MAX	UNIT
C <sub>ISS</sub>	Input Capacitance	V <sub>DS</sub> = 50 V, V <sub>GS</sub> = 0 V		94	150	pF
C <sub>RSS</sub>	Reverse Transfer Capacitance			0.9		
C <sub>OSS</sub>	Output Capacitance			63	72	
C <sub>OSS(ER)</sub>	Effective Output Capacitance, Energy Related (Note 1)	V <sub>DS</sub> = 0 to 50 V, V <sub>GS</sub> = 0 V		74		pF
C <sub>OSS(TR)</sub>	Effective Output Capacitance, Time Related (Note 2)			93		
R <sub>G</sub>	Gate Resistance			1.0		Ω
Q <sub>G</sub>	Total Gate Charge	V <sub>DS</sub> = 50 V, V <sub>GS</sub> = 5 V, I <sub>D</sub> = 4 A		0.85	1.2	nC
Q <sub>GS</sub>	Gate to Source Charge	V <sub>DS</sub> = 50 V, I <sub>D</sub> = 4 A		0.27		
Q <sub>GD</sub>	Gate to Drain Charge			0.19		
Q <sub>G(TH)</sub>	Gate Charge at Threshold			0.19		
Q <sub>OSS</sub>	Output Charge	V <sub>DS</sub> = 50 V, V <sub>GS</sub> = 0 V		4.7	5.6	
Q <sub>RR</sub>	Source-Drain Recovery Charge			0		

# Defined by design. Not subject to production test.

All measurements were done with substrate connected to source.

Note 1: C<sub>OSS(ER)</sub> is a fixed capacitance that gives the same stored energy as C<sub>OSS</sub> while V<sub>DS</sub> is rising from 0 to 50% BV<sub>DSS</sub>.

Note 2: C<sub>OSS(TR)</sub> is a fixed capacitance that gives the same charging time as C<sub>OSS</sub> while V<sub>DS</sub> is rising from 0 to 50% BV<sub>DSS</sub>.

Figure 1: Typical Output Characteristics at 25°C

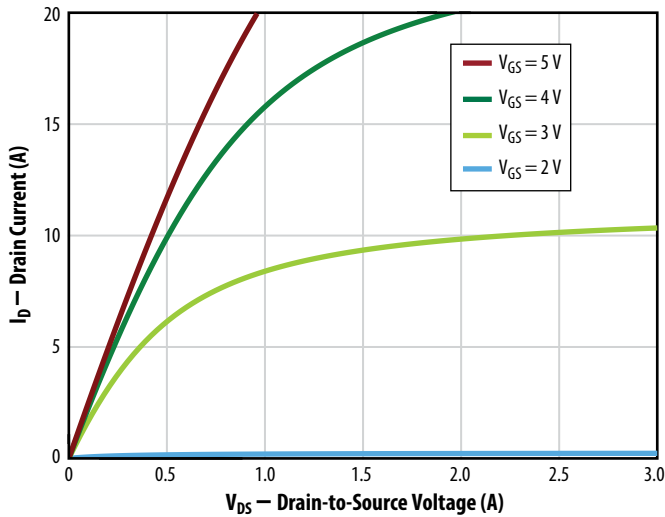

Figure 2: Typical Transfer Characteristics

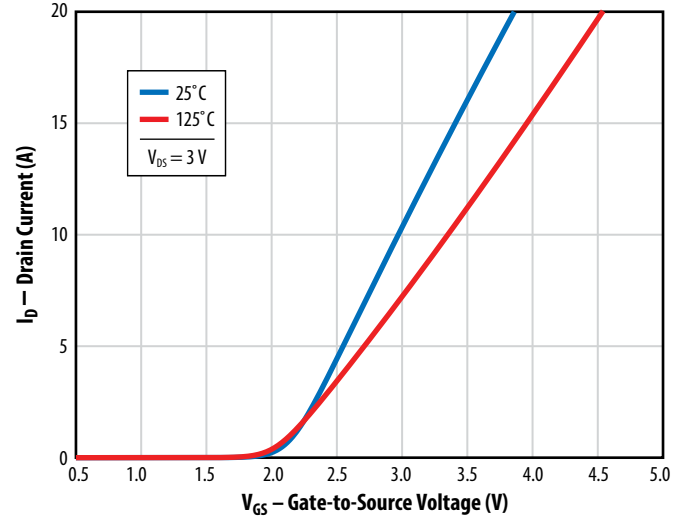

Figure 3: Typical R<sub>DS(on)</sub> vs. V<sub>GS</sub> for Various Drain Currents

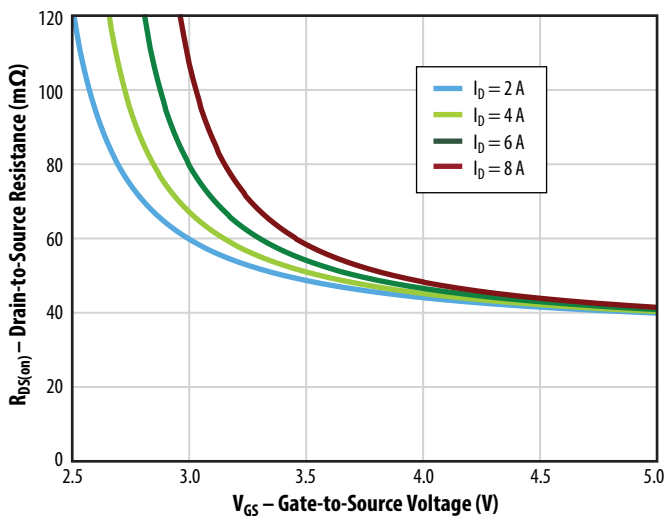

Figure 4: Typical R<sub>DS(on)</sub> vs. V<sub>GS</sub> for Various Temperatures

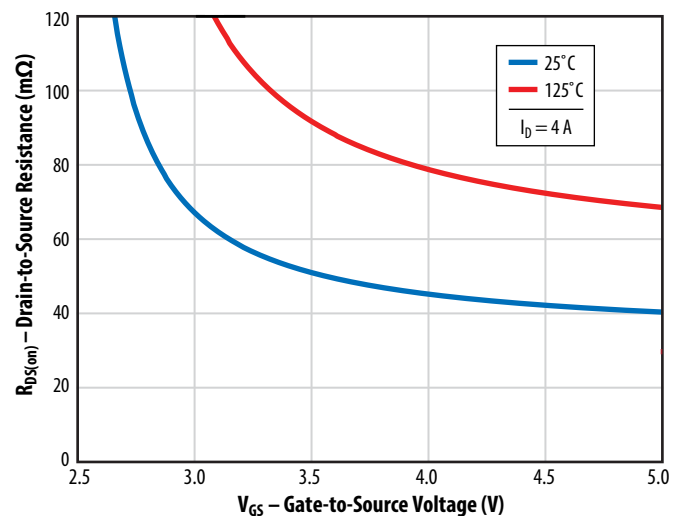

Figure 5a: Typical Capacitance (Linear Scale)

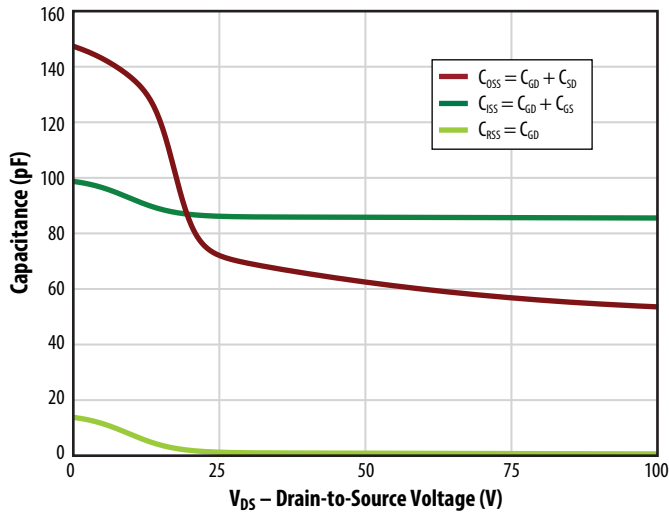

Figure 5b: Typical Capacitance (Log Scale)

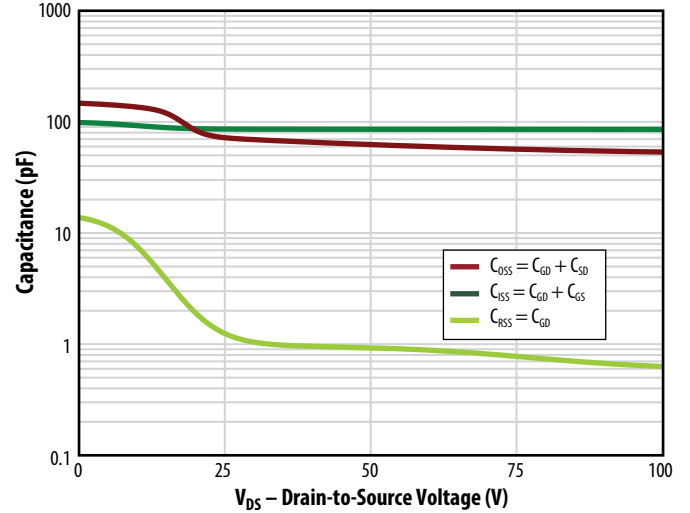

Figure 6: Typical Output Charge and C\_oss Stored Energy

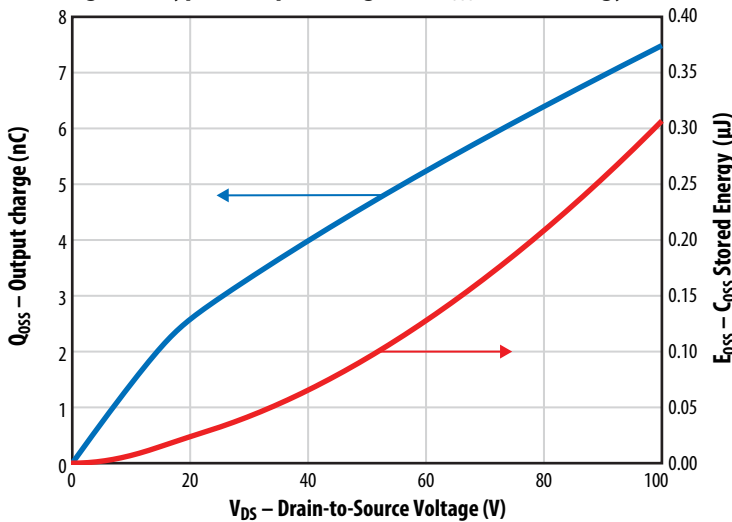

Figure 7: Typical Typical Gate Charge

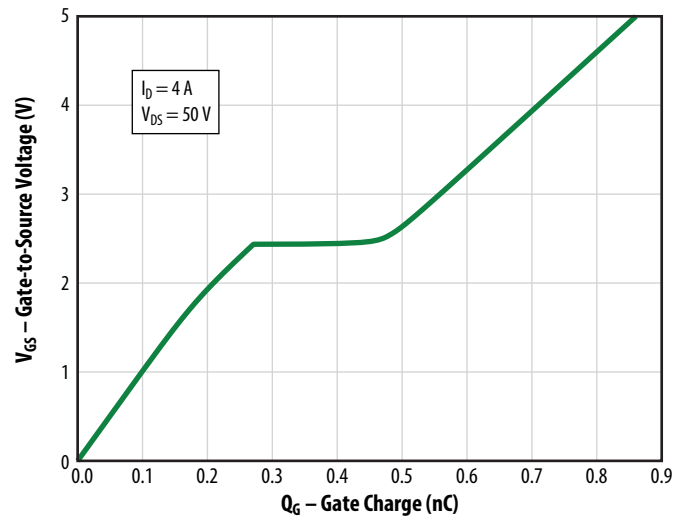

Figure 8: Typical Reverse Drain-Source Characteristics

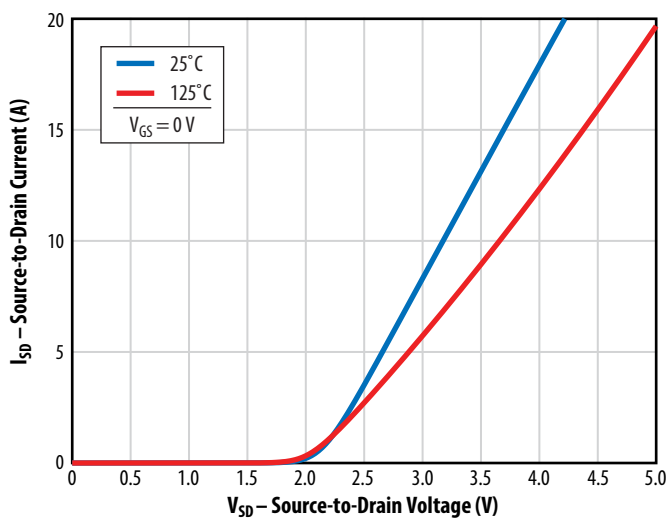
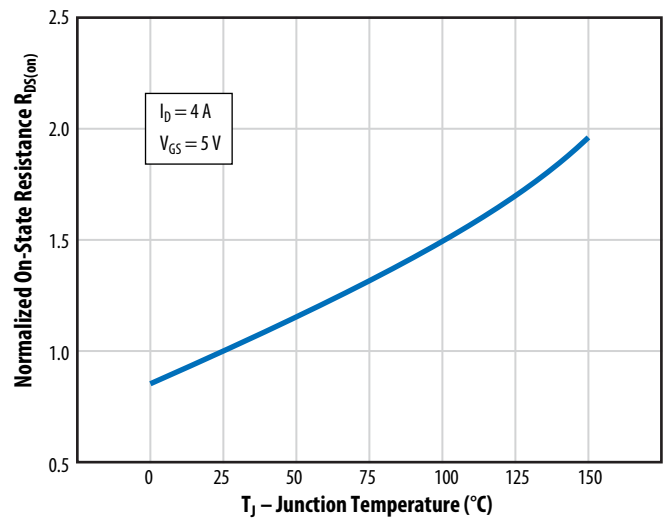

Figure 9: Typical Normalized On-State Resistance vs. Temp.



Note: Negative gate drive voltage increases the reverse drain-source voltage.  
EPC recommends 0V for OFF.

All measurements were done with substrate shorted to source.

Figure 10: Typical Normalized Threshold Voltage vs. Temp.

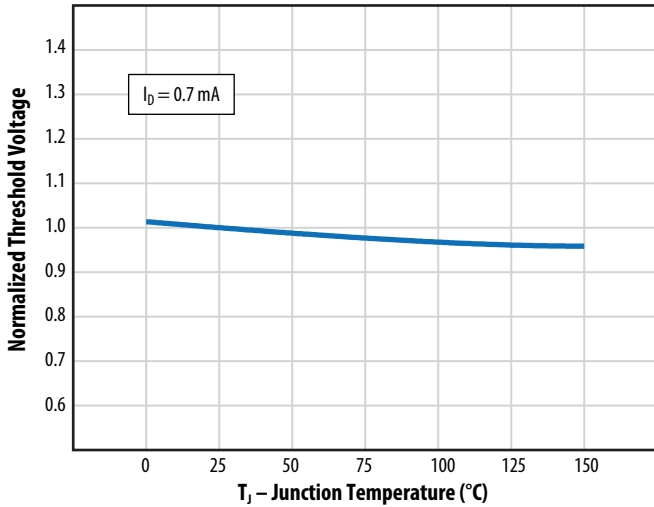

Figure 11: Safe Operating Area

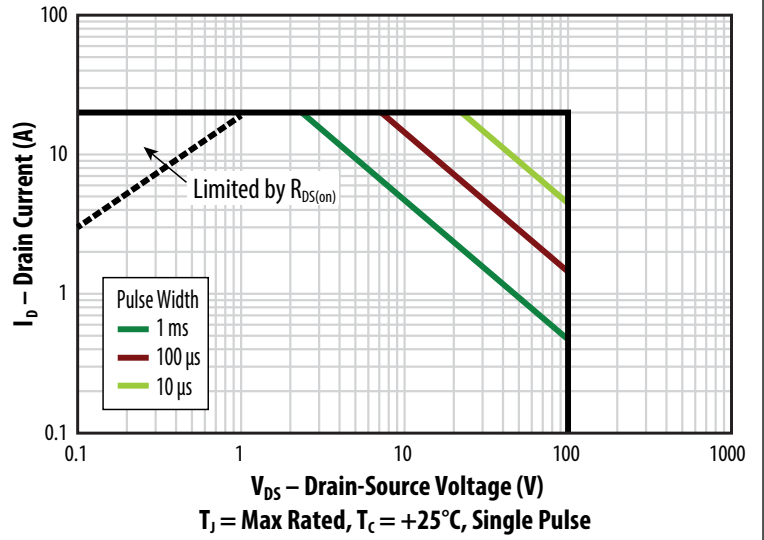
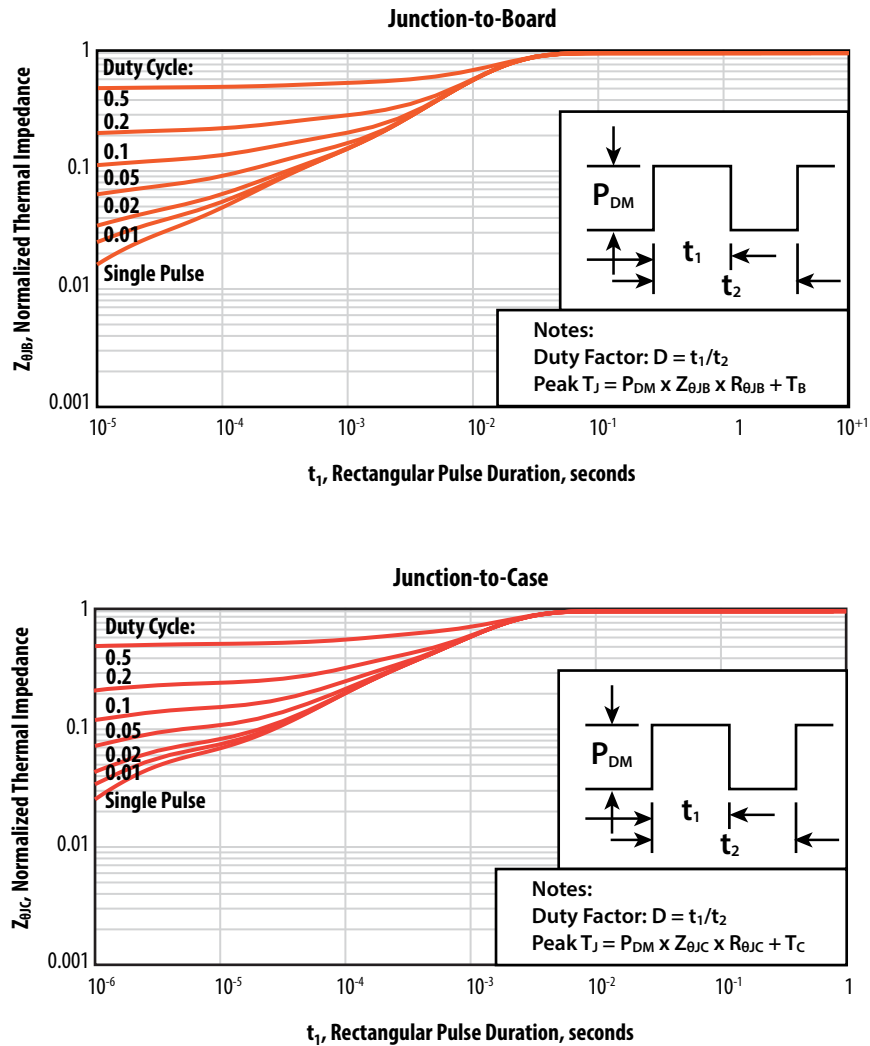
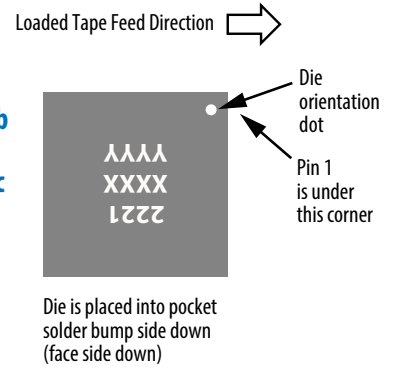
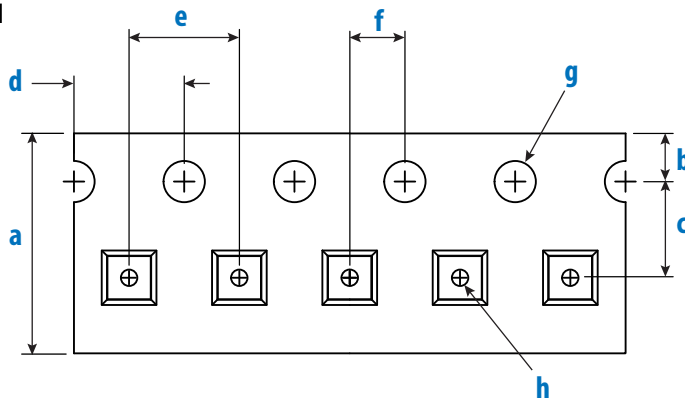
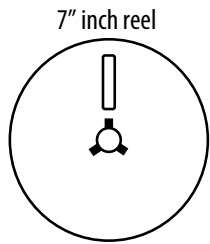

Figure 12: Typical Transient Thermal Response Curves



**TAPE AND REEL CONFIGURATION**

4 mm pitch, 8 mm wide tape on 7" reel



EPC2221 (Note 1)	Dimension (mm)		
	Target	MIN	MAX
a	8.00	7.90	8.30
b	1.75	1.65	1.85
c (Note 2)	3.50	3.45	3.55
d	4.00	3.90	4.10
e	4.00	3.90	4.10
f (Note 2)	2.00	1.95	2.05
g	1.50	1.40	1.60
h	0.60	0.65	0.50

Note 1: MSL 1 (moisture sensitivity level 1) classified according to IPC/JEDEC industry standard.

Note 2: Pocket position is relative to the sprocket hole measured as true position of the pocket, not the pocket hole.

**DIE MARKINGS**

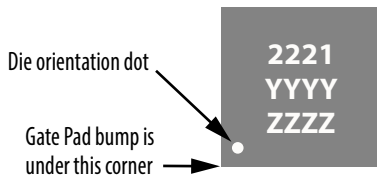

Part Number	Laser Markings		
	Part # Marking Line 1	Lot Date Code Marking Line 2	Lot Date Code Marking Line 3
EPC2221	2221	YYYY	ZZZZ

**DIE OUTLINE**

Solder Bump View

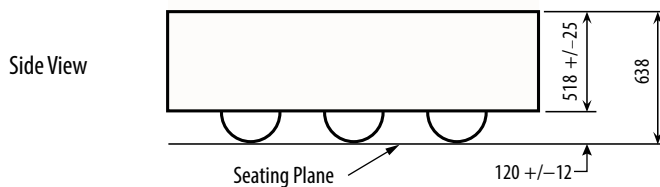
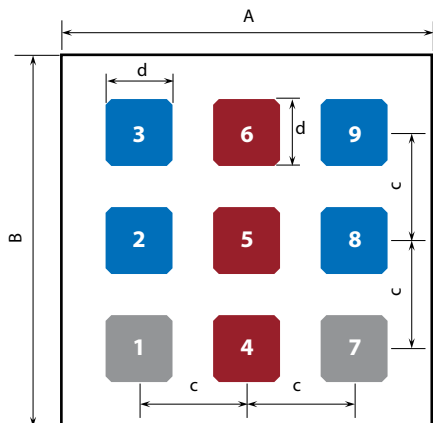

DIM	Micrometers		
	MIN	Nominal	MAX
A	1320	1350	1380
B	1320	1350	1380
c		450	
d		225	

Pad 1 is Gate 1;

Pad 7 is Gate 2;

Pad 2, 3 are Drain 1;

Pad 8, 9 are Drain 2;

Pad 4, 5, 6 are Source

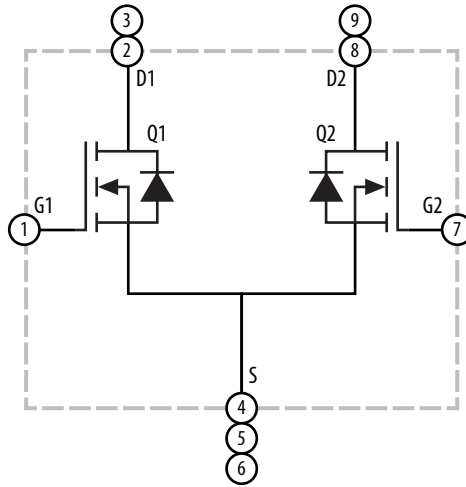

**EPC2221 – Detailed Schematic**

Note: The EPC2221 can be connected in parallel or used as independent FETs with common source.

**RECOMMENDED LAND PATTERN**  
(measurements in  $\mu\text{m}$ )

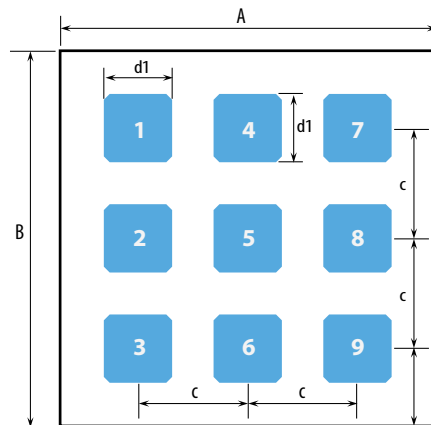

The land pattern is solder mask defined.

DIM	Micrometers
<b>A</b>	1350
<b>B</b>	1350
<b>c</b>	450
<b>d1</b>	205

**RECOMMENDED STENCIL DRAWING**  
(measurements in  $\mu\text{m}$ )

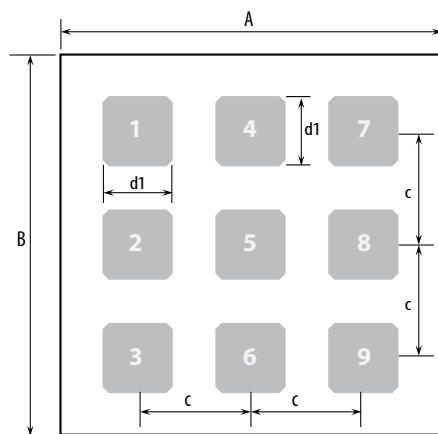

DIM	Micrometers
<b>A</b>	1350
<b>B</b>	1350
<b>c</b>	450
<b>d1</b>	225

Recommended stencil should be 4 mil (100  $\mu\text{m}$ ) thick, must be laser cut, openings per drawing.

Intended for use with SAC305 Type 4 solder, reference 88.5% metals content.

**Additional Resources Available**

- Assembly resources available at: <https://epc-co.com/epc/design-support>
- Library of Altium footprints for production FETs and ICs: <https://epc-co.com/epc/documents/altium-files/EPC%20Altium%20Library.zip> (for preliminary device Altium footprints, contact EPC)

Efficient Power Conversion Corporation (EPC) reserves the right to make changes without further notice to any products herein to improve reliability, function or design. EPC does not assume any liability arising out of the application or use of any product or circuit described herein; neither does it convey any license under its patent rights, nor the rights of others.

eGaN® is a registered trademark of Efficient Power Conversion Corporation.  
EPC Patent Listing: <https://epc-co.com/epc/about-epc/patents>

Information subject to change without notice.