

EPC2214 – Automotive 80 V (D-S) Enhancement Mode Power Transistor

 $V_{DS}, 80\text{ V}$
 $R_{DS(on)}, 20\text{ m}\Omega$
 $I_D, 10\text{ A}$

AEC-Q101

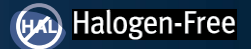

Gallium Nitride's exceptionally high electron mobility and low temperature coefficient allows very low $R_{DS(on)}$, while its lateral device structure and majority carrier diode provide exceptionally low Q_G and zero Q_{RR} . The end result is a device that can handle tasks where very high switching frequency, and low on-time are beneficial as well as those where on-state losses dominate.

Application Notes:

- Easy-to-use and reliable gate
- Gate Drive ON = 5-5.25 V typical, OFF = 0 V (negative voltage not needed)
- Top of FET is electrically connected to source

Questions:



Maximum Ratings			
PARAMETER		VALUE	UNIT
V_{DS}	Drain-to-Source Voltage (Continuous)	80	V
I_D	Continuous ($T_A = 25^\circ\text{C}$)	10	A
	Pulsed (25°C , $T_{PULSE} = 10\ \mu\text{s}$)	60	
V_{GS}	Gate-to-Source Voltage	6	V
	Gate-to-Source Voltage	-4	
T_J	Operating Temperature	-40 to 150	$^\circ\text{C}$
T_{STG}	Storage Temperature	-40 to 150	

Thermal Characteristics			
PARAMETER		TYP	UNIT
$R_{\theta JC}$	Thermal Resistance, Junction-to-Case	2.7	$^\circ\text{C}/\text{W}$
$R_{\theta JB}$	Thermal Resistance, Junction-to-Board	7.5	
$R_{\theta JA}$	Thermal Resistance, Junction-to-Ambient (Note 1)	81	

Note 1: $R_{\theta JA}$ is determined with the device mounted on one square inch of copper pad, single layer 2 oz copper on FR4 board. See https://epc-co.com/epc/documents/product-training/Appnote_Thermal_Performance_of_eGaN_FETs.pdf for details

Static Characteristics ($T_J = 25^\circ\text{C}$ unless otherwise stated)						
PARAMETER		TEST CONDITIONS	MIN	TYP	MAX	UNIT
BV_{DSS}	Drain-to-Source Voltage	$V_{GS} = 0\text{ V}$, $I_D = 0.2\text{ mA}$	80			V
I_{DSS}	Drain-Source Leakage	$V_{DS} = 64\text{ V}$, $V_{GS} = 0\text{ V}$		0.003	0.15	mA
I_{GSS}	Gate-to-Source Forward Leakage	$V_{GS} = 5\text{ V}$		0.003	1.1	mA
	Gate-to-Source Forward Leakage [#]	$V_{GS} = 5\text{ V}$, $T_J = 125^\circ\text{C}$		0.01	2.5	mA
	Gate-to-Source Reverse Leakage	$V_{GS} = -4\text{ V}$		0.003	0.15	mA
$V_{GS(TH)}$	Gate Threshold Voltage	$V_{DS} = V_{GS}$, $I_D = 2\text{ mA}$	0.8	1.4	2.5	V
$R_{DS(on)}$	Drain-Source On Resistance	$V_{GS} = 5\text{ V}$, $I_D = 6\text{ A}$		15	20	m Ω
V_{SD}	Source-Drain Forward Voltage [#]	$I_S = 0.5\text{ A}$, $V_{GS} = 0\text{ V}$		1.9		V

[#] Defined by design. Not subject to production test.

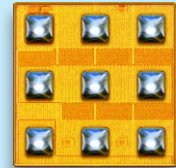

Die Size: 1.35 x 1.35 mm

EPC2214 eGaN® FETs are supplied only in passivated die form with solder bumps

Applications

- Lidar/Pulsed Power Applications
- DC-DC Conversion
- Wireless Power Transfer

Benefits

- Ultra High Efficiency
- Ultra Low $R_{DS(on)}$
- Ultra Low Q_G
- Ultra Small Footprint

Scan QR code or click link below for more information including reliability reports, device models, demo boards!



<https://l.ead.me/EPC2214>

Dynamic Characteristics* (T_J = 25°C unless otherwise stated)

PARAMETER		TEST CONDITIONS	MIN	TYP	MAX	UNIT
C _{ISS}	Input Capacitance	V _{DS} = 40 V, V _{GS} = 0 V		198	238	pF
C _{RSS}	Reverse Transfer Capacitance			1.8		
C _{OSS}	Output Capacitance			129	194	
C _{OSS(ER)}	Effective Output Capacitance, Energy Related (Note 2)	V _{DS} = 0 to 40 V, V _{GS} = 0 V		171		
C _{OSS(TR)}	Effective Output Capacitance, Time Related (Note 3)			211		
R _G	Gate Resistance			0.65		Ω
Q _G	Total Gate Charge	V _{DS} = 40 V, V _{GS} = 5 V, I _D = 6 A		1.8	2.2	nC
Q _{GS}	Gate to Source Charge	V _{DS} = 40 V, I _D = 6 A		0.5		
Q _{GD}	Gate to Drain Charge			0.3		
Q _{G(TH)}	Gate Charge at Threshold			0.4		
Q _{OSS}	Output Charge	V _{DS} = 40 V, V _{GS} = 0 V		8	12	
Q _{RR}	Source-Drain Recovery Charge			0		

Defined by design. Not subject to production test.

Note 2: C_{OSS(ER)} is a fixed capacitance that gives the same stored energy as C_{OSS} while V_{DS} is rising from 0 to 50% BV_{DSS}.

Note 3: C_{OSS(TR)} is a fixed capacitance that gives the same charging time as C_{OSS} while V_{DS} is rising from 0 to 50% BV_{DSS}.

Figure 1: Typical Output Characteristics at 25°C

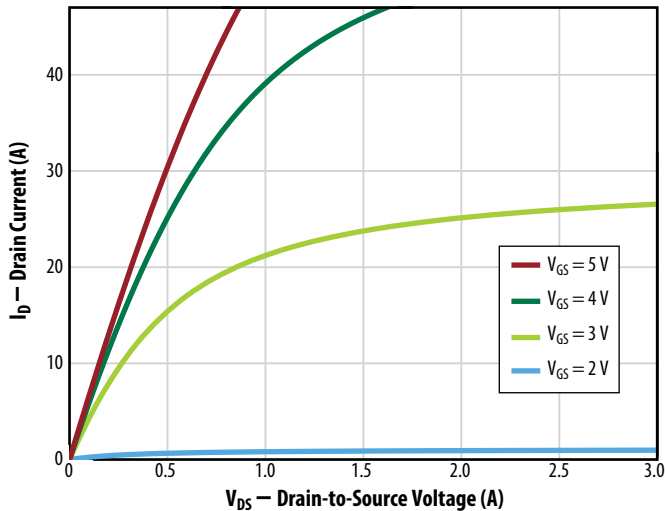

Figure 2: Transfer Characteristics

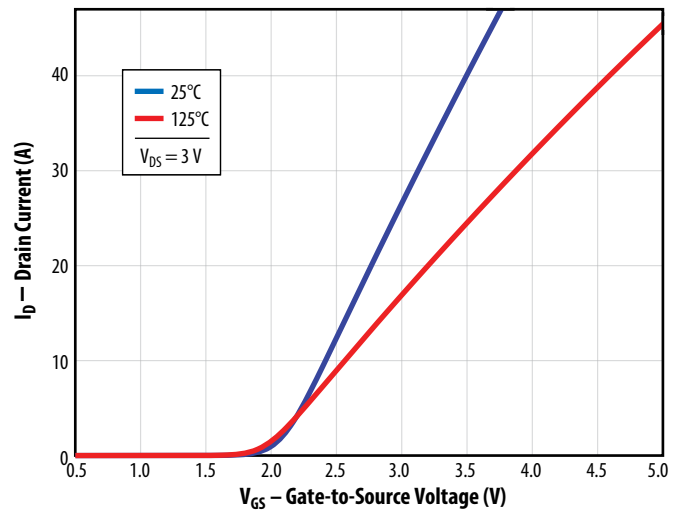

Figure 3: R_{DS(on)} vs. V_{GS} for Various Drain Currents

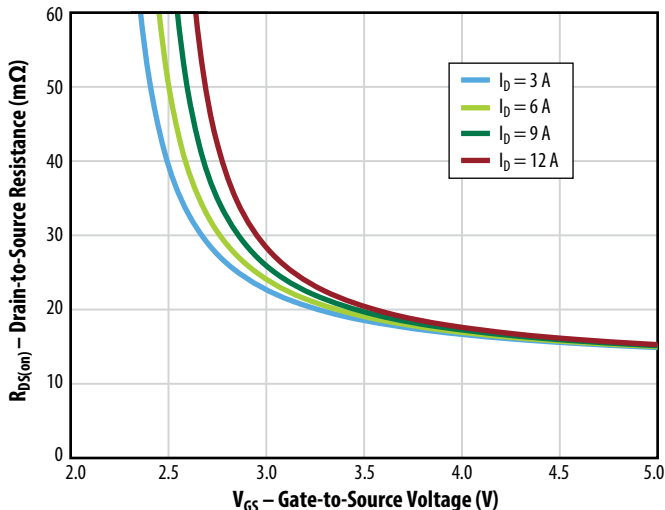

Figure 4: R_{DS(on)} vs. V_{GS} for Various Temperatures

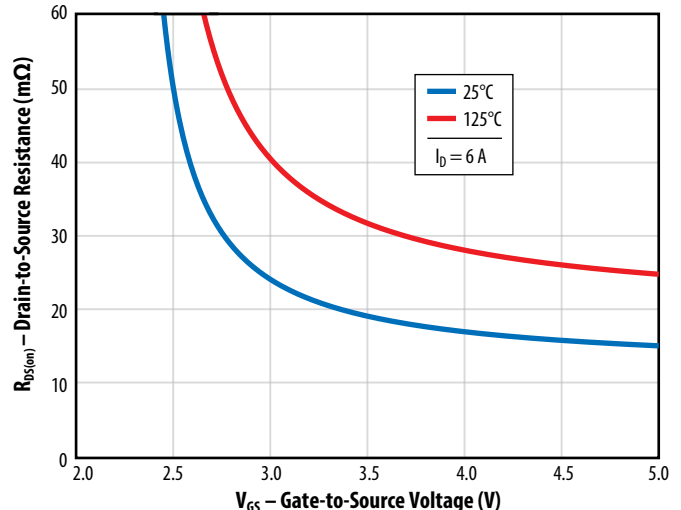

Figure 5a: Capacitance (Linear Scale)

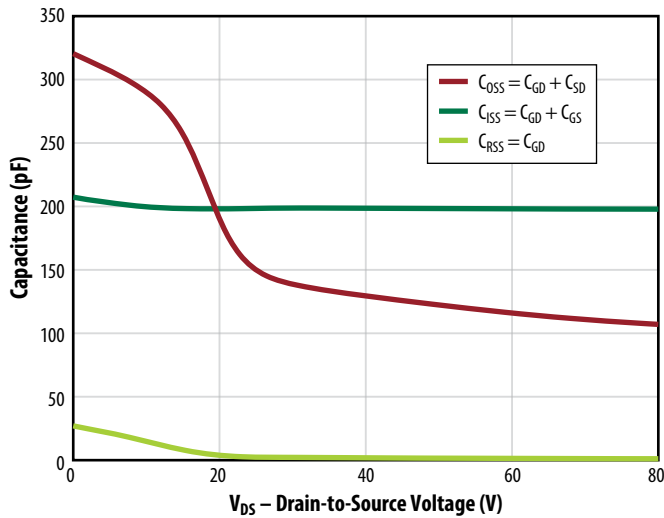

Figure 5b: Capacitance (Log Scale)

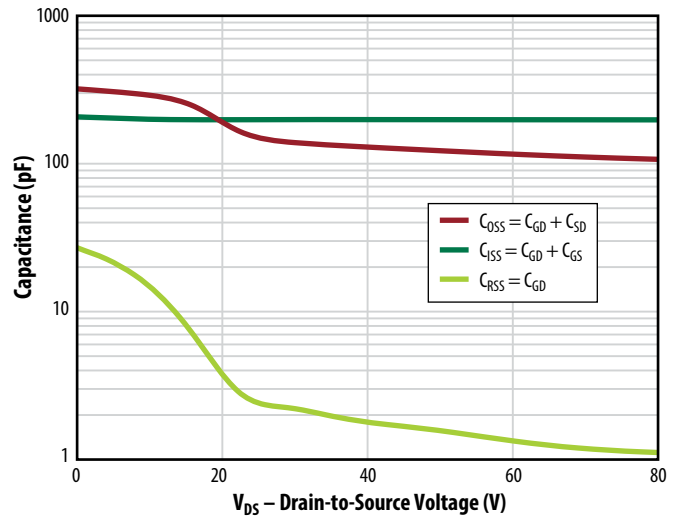

Figure 6: Output Charge and C_{OSS} Stored Energy

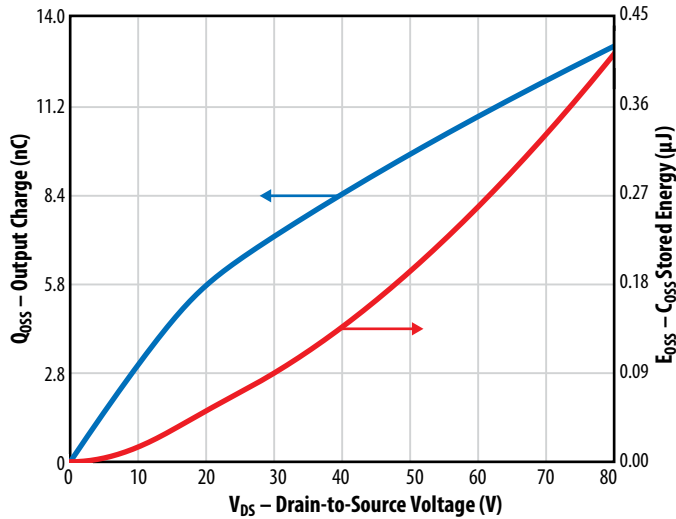

Figure 7: Gate Charge

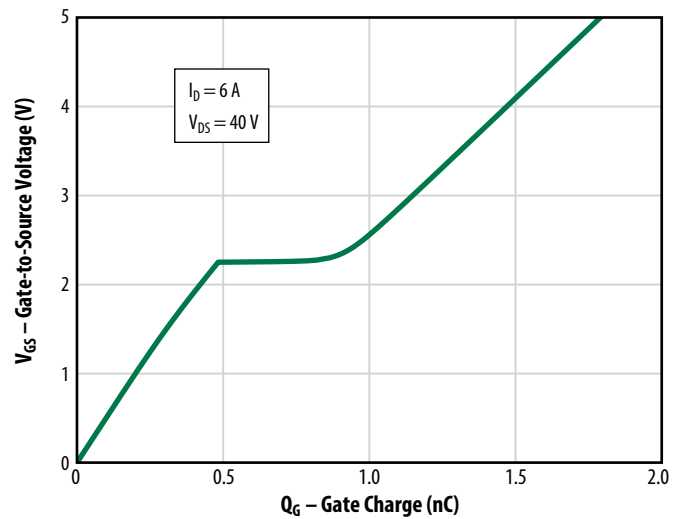
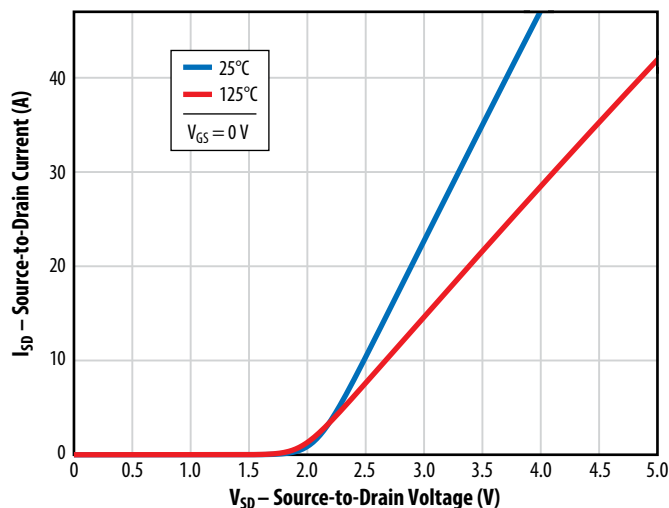

Figure 8: Reverse Drain-Source Characteristics



Note: Negative gate drive voltage increases the reverse drain-source voltage. EPC recommends 0 V for OFF.

Figure 9: Normalized On-State Resistance vs. Temperature

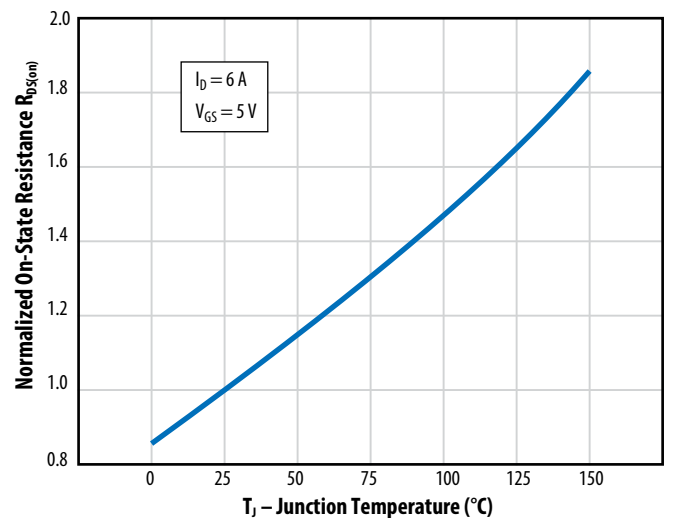

Figure 10: Normalized Threshold Voltage vs. Temperature

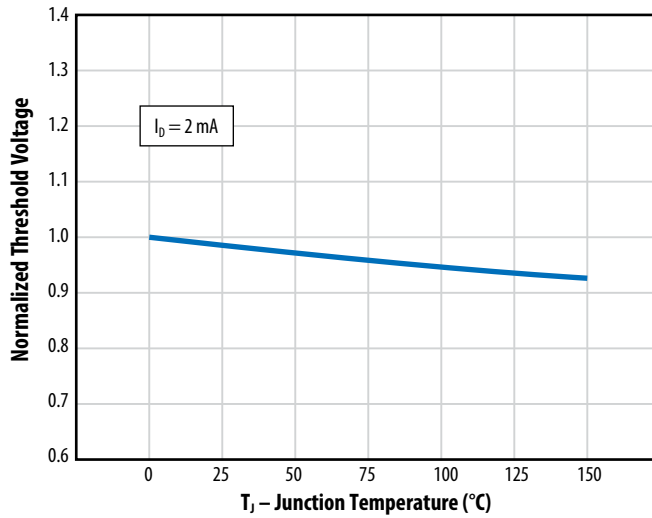

Figure 11: Transient Thermal Response Curves

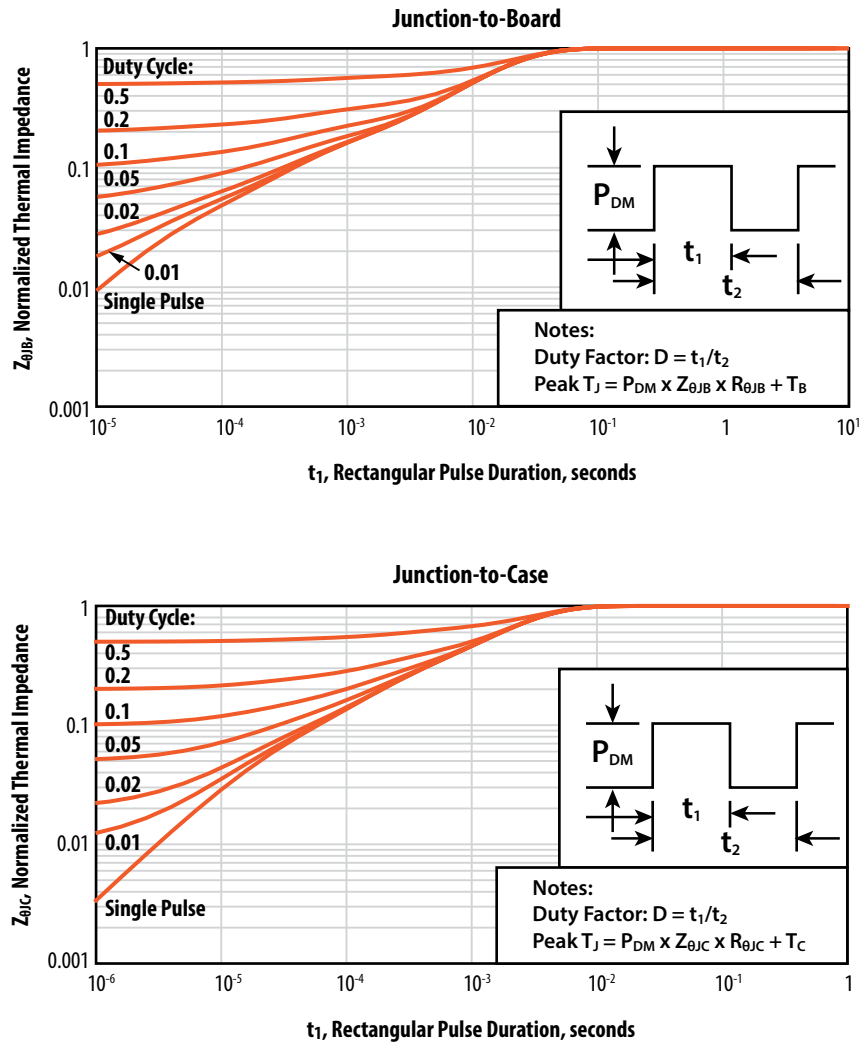
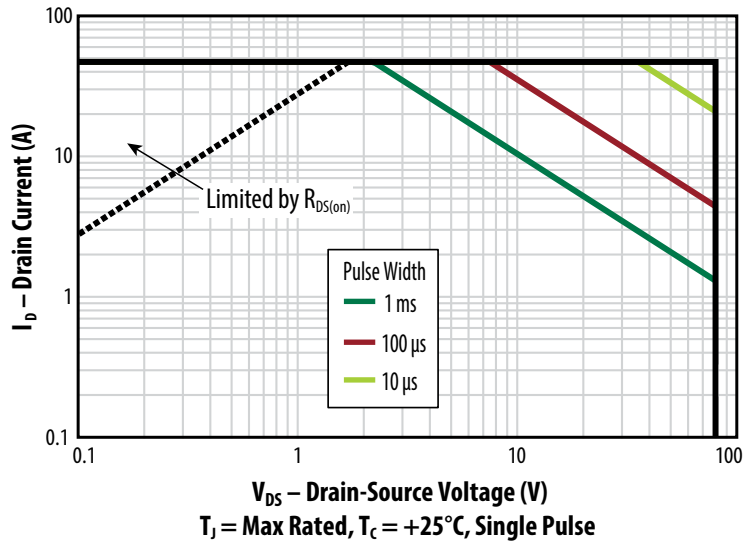
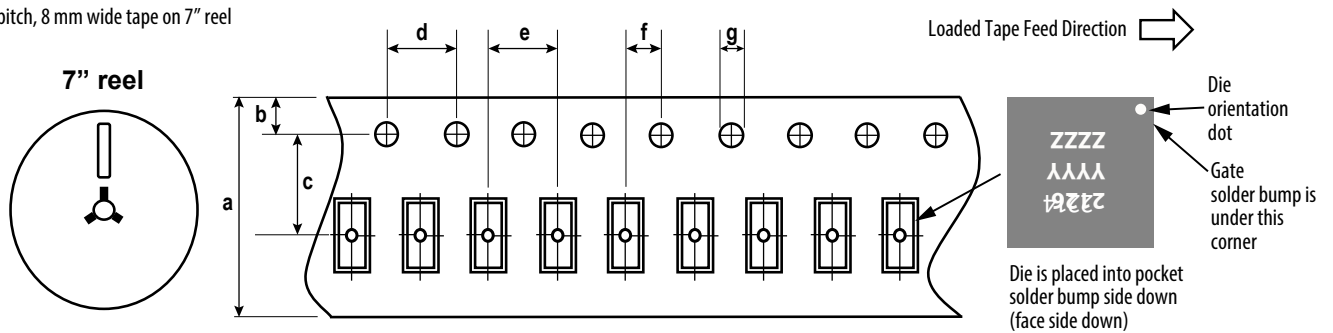

Figure 12: Safe Operating Area



TAPE AND REEL CONFIGURATION

4 mm pitch, 8 mm wide tape on 7" reel



EPC2126 (Note 1)	Dimension (mm)		
	Target	MIN	MAX
a	8.00	7.90	8.30
b	1.75	1.65	1.85
c (Note 2)	3.50	3.45	3.55
d	4.00	3.90	4.10
e	4.00	3.90	4.10
f (Note 2)	2.00	1.95	2.05
g	1.50	1.50	1.60

Note 1: MSL 1 (moisture sensitivity level 1) classified according to IPC/JEDEC industry standard.

Note 2: Pocket position is relative to the sprocket hole measured as true position of the pocket, not the pocket hole.

DIE MARKINGS

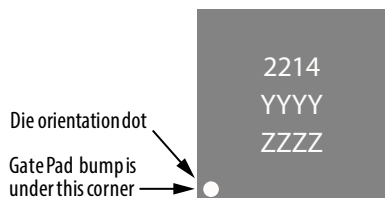

Part Number	Laser Markings		
	Part # Marking Line 1	Lot_Date Code Marking Line 2	Lot_Date Code Marking Line 3
EPC2214	2214	YYYYY	ZZZZ

DIE OUTLINE

Pad View

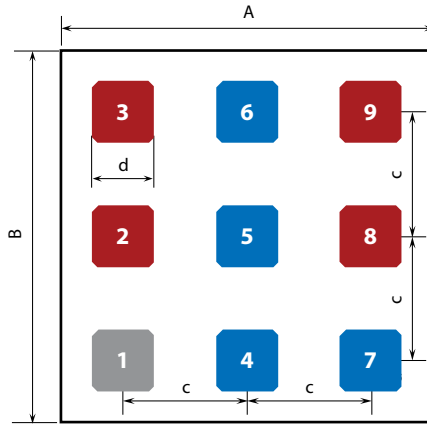

DIM	Micrometers		
	MIN	Nominal	MAX
A	1320	1350	1380
B	1320	1350	1380
c		450	
d		225	

Pad 1 is Gate;

Pads 4, 5, 6, 7 are Drain;

Pads 2, 3, 8, 9 are Source.

Side View

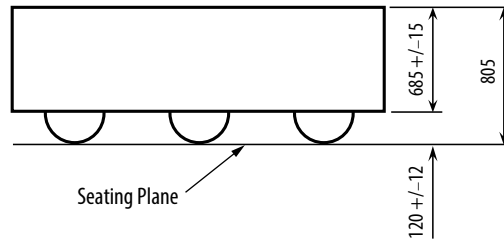

RECOMMENDED LAND PATTERN

(measurements in μm)

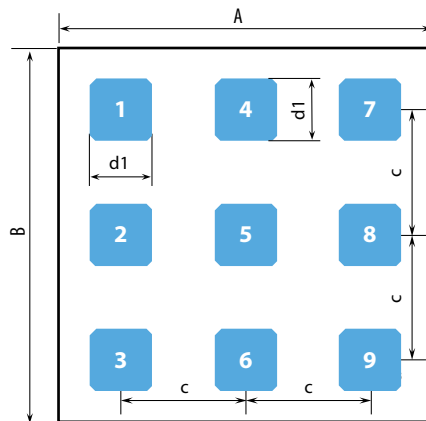

DIM	Micrometers
A	1350
B	1350
c	450
d1	205

The land pattern is solder mask defined
Solder mask is 10 μm smaller per side than bump

Pad 1 is Gate;

Pads 4, 5, 6, 7 are Drain;

Pads 2, 3, 8, 9 are Source.

RECOMMENDED STENCIL DRAWING

(measurements in μm)

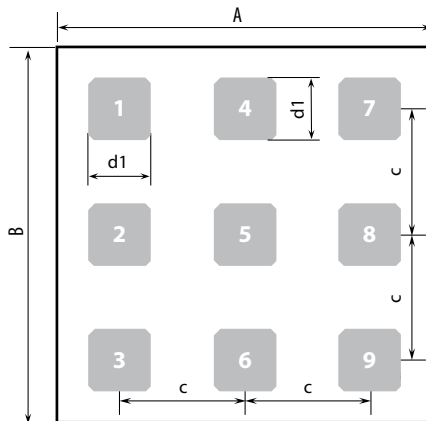

DIM	Micrometers
A	1350
B	1350
c	450
d1	225

Recommended stencil should be 4 mil (100 μm) thick,
must be laser cut, openings per drawing.

The corner has a radius of R60.

Intended for use with SAC305 Type 4 solder,
reference 88.5% metals content.

Additional assembly resources available at

<https://epc-co.com/epc/design-support>

Efficient Power Conversion Corporation (EPC) reserves the right to make changes without further notice to any products herein to improve reliability, function or design. EPC does not assume any liability arising out of the application or use of any product or circuit described herein; neither does it convey any license under its patent rights, nor the rights of others.

eGaN® is a registered trademark of Efficient Power Conversion Corporation.

EPC Patent Listing: <https://epc-co.com/epc/about-epc/patents>

Information subject to change without notice.

Revised September 2024