

# EPC2102 – Enhancement-Mode GaN Power Transistor Half-Bridge

$V_{DS}$ , 60 V

$R_{DS(on)}$ , 4.9 mΩ

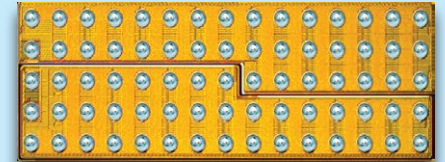
$I_D$ , 30 A



Revised August 29, 2024

Gallium Nitride's exceptionally high electron mobility and low temperature coefficient allows very low  $R_{DS(on)}$ , while its lateral device structure and majority carrier diode provide exceptionally low  $Q_G$  and zero  $Q_{RR}$ . The end result is a device that can handle tasks where very high switching frequency, and low on-time are beneficial as well as those where on-state losses dominate.

Questions:  
Ask a GaN  
Expert



Die Size: 6.05 x 2.3 mm

EPC2102 eGaN® ICs are supplied only in passivated die form with solder bumps.

## Applications

- High frequency DC-DC

## Benefits

- High frequency operation
- Ultra high efficiency
- High density footprint

Maximum Ratings				
DEVICE	PARAMETER		VALUE	UNIT
Q1 & Q2	$V_{DS}$	Drain-to-Source Voltage (Continuous)	60	V
		Drain-to-Source Voltage (up to 10,000 5 ms pulses at 150°C)	72	
	$I_D$	Continuous ( $T_A = 25^\circ\text{C}$ , $R_{\theta JA} = 15^\circ\text{C/W}$ )	30	A
		Pulsed ( $25^\circ\text{C}$ , $T_{PULSE} = 300 \mu\text{s}$ )	220	
	$V_{GS}$	Gate-to-Source Voltage	6	V
		Gate-to-Source Voltage	-4	
$T_J$	Operating Temperature	-40 to 150	°C	
$T_{STG}$	Storage Temperature	-40 to 150		

Thermal Characteristics				
	PARAMETER		TYP	UNIT
Q1 & Q2	$R_{\theta JC}$	Thermal Resistance, Junction-to-Case	0.3	°C/W
	$R_{\theta JB}$	Thermal Resistance, Junction-to-Board	2.2	
	$R_{\theta JA}$	Thermal Resistance, Junction-to-Ambient (Note 1)	42	

Note 1:  $R_{\theta JA}$  is determined with the device mounted on one square inch of copper pad, single layer 2 oz copper on FR4 board. See [https://epc-co.com/epc/documents/product-training/Appnote\\_Thermal\\_Performance\\_of\\_eGaN\\_FETs.pdf](https://epc-co.com/epc/documents/product-training/Appnote_Thermal_Performance_of_eGaN_FETs.pdf) for details

Static Characteristics ( $T_J = 25^\circ\text{C}$ unless otherwise stated)							
DEVICE	PARAMETER		TEST CONDITIONS	MIN	TYP	MAX	UNIT
Q1 & Q2	$BV_{DSS}$	Drain-to-Source Voltage	$V_{GS} = 0 \text{ V}$ , $I_D = 0.6 \text{ mA}$	60			V
	$I_{DSS}$	Drain-Source Leakage	$V_{DS} = 48 \text{ V}$ , $V_{GS} = 0 \text{ V}$		0.008	0.4	mA
	$I_{GSS}$	Gate-to-Source Forward Leakage <sup>#</sup>	$V_{GS} = 5 \text{ V}$		0.015	7	mA
		Gate-to-Source Reverse Leakage	$V_{GS} = -4 \text{ V}$		0.008	0.4	mA
	$V_{GS(TH)}$	Gate Threshold Voltage	$V_{DS} = V_{GS}$ , $I_D = 7 \text{ mA}$	0.8	1.3	2.5	V
	$R_{DS(on)}$	Drain-Source On Resistance	$V_{GS} = 5 \text{ V}$ , $I_D = 20 \text{ A}$		3.6	4.9	mΩ
$V_{SD}$	Source-Drain Forward Voltage <sup>#</sup>	$I_S = 0.5 \text{ A}$ , $V_{GS} = 0 \text{ V}$		1.7		V	

<sup>#</sup> Defined by design. Not subject to production test.

Scan QR code or click link below for more information including reliability reports, device models, demo boards!



<https://l.ead.me/EPC2102>

Dynamic Characteristics\* (T<sub>j</sub> = 25°C unless otherwise stated)

DEVICE	PARAMETER		TEST CONDITIONS	MIN	TYP	MAX	UNIT
Q1	C <sub>ISS</sub>	Input Capacitance	V <sub>DS</sub> = 30 V, V <sub>GS</sub> = 0 V		850	1020	pF
	C <sub>RSS</sub>	Reverse Transfer Capacitance			11		
	C <sub>OSS</sub>	Output Capacitance			500	750	
	C <sub>OSS(ER)</sub>	Effective Output Capacitance, Energy Related (Note 2)	V <sub>DS</sub> = 0 to 30 V, V <sub>GS</sub> = 0 V		695		
	C <sub>OSS(TR)</sub>	Effective Output Capacitance, Time Related (Note 3)			863		
	Q <sub>G</sub>	Total Gate Charge	V <sub>DS</sub> = 30 V, V <sub>GS</sub> = 5 V, I <sub>D</sub> = 20 A		8	11	nC
	Q <sub>GS</sub>	Gate-to-Source Charge	V <sub>DS</sub> = 30 V, I <sub>D</sub> = 20 A		2.5		
	Q <sub>GD</sub>	Gate-to-Drain Charge			1.5		
	Q <sub>G(TH)</sub>	Gate Charge at Threshold			1.7		
	Q <sub>OSS</sub>	Output Charge	V <sub>DS</sub> = 30 V, V <sub>GS</sub> = 0 V		26	39	
	Q <sub>RR</sub>	Source-Drain Recovery Charge			0		
Q2	C <sub>ISS</sub>	Input Capacitance	V <sub>DS</sub> = 30 V, V <sub>GS</sub> = 0 V		850	1020	pF
	C <sub>RSS</sub>	Reverse Transfer Capacitance			11		
	C <sub>OSS</sub>	Output Capacitance			610	915	
	C <sub>OSS(ER)</sub>	Effective Output Capacitance, Energy Related (Note 2)	V <sub>DS</sub> = 0 to 30 V, V <sub>GS</sub> = 0 V		830		
	C <sub>OSS(TR)</sub>	Effective Output Capacitance, Time Related (Note 3)			1030		
	Q <sub>G</sub>	Total Gate Charge	V <sub>DS</sub> = 30 V, V <sub>GS</sub> = 5 V, I <sub>D</sub> = 20 A		8	11	nC
	Q <sub>GS</sub>	Gate-to-Source Charge	V <sub>DS</sub> = 30 V, I <sub>D</sub> = 20 A		2.5		
	Q <sub>GD</sub>	Gate-to-Drain Charge			1.5		
	Q <sub>G(TH)</sub>	Gate Charge at Threshold			1.7		
	Q <sub>OSS</sub>	Output Charge	V <sub>DS</sub> = 30 V, V <sub>GS</sub> = 0 V		31	47	
	Q <sub>RR</sub>	Source-Drain Recovery Charge			0		

# Defined by design. Not subject to production test.

All measurements were done with substrate connected to source.

Note 2: C<sub>OSS(ER)</sub> is a fixed capacitance that gives the same stored energy as C<sub>OSS</sub> while V<sub>DS</sub> is rising from 0 to 50% BV<sub>DSS</sub>.

Note 3: C<sub>OSS(TR)</sub> is a fixed capacitance that gives the same charging time as C<sub>OSS</sub> while V<sub>DS</sub> is rising from 0 to 50% BV<sub>DSS</sub>.

Figure 1 (Q1 & Q2): Typical Output Characteristics at 25°C

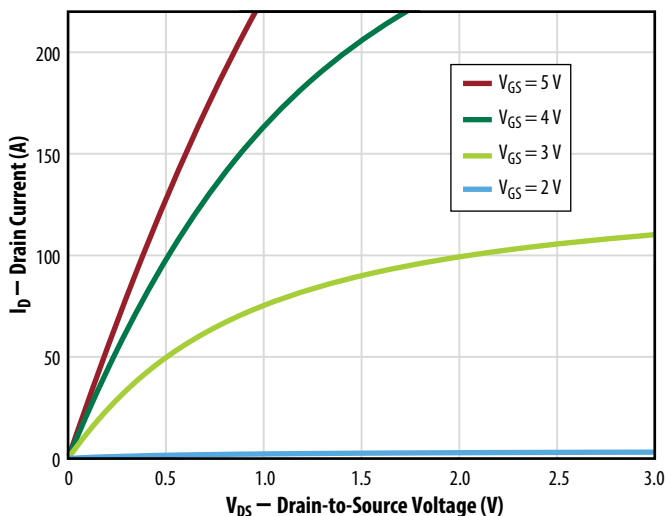
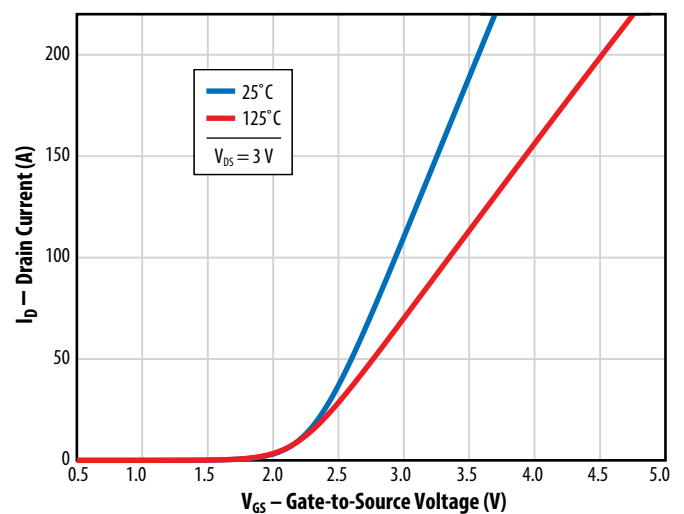
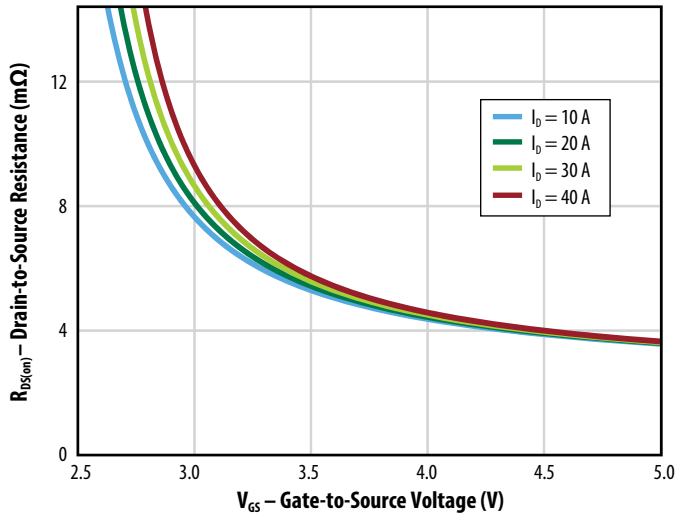


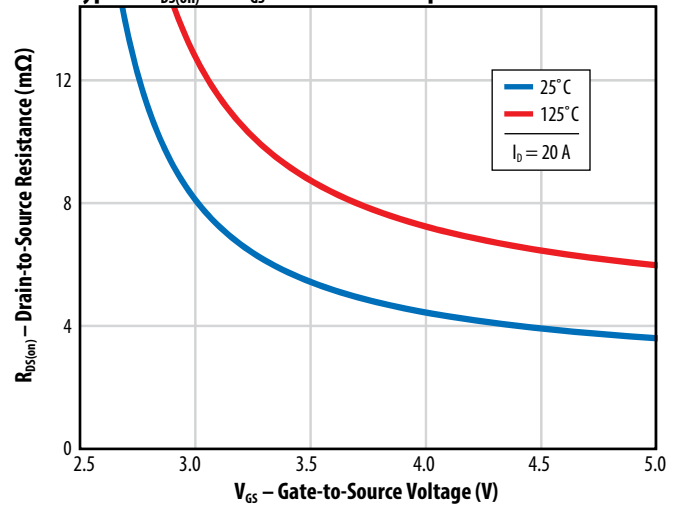
Figure 2 (Q1 & Q2): Typical Transfer Characteristics



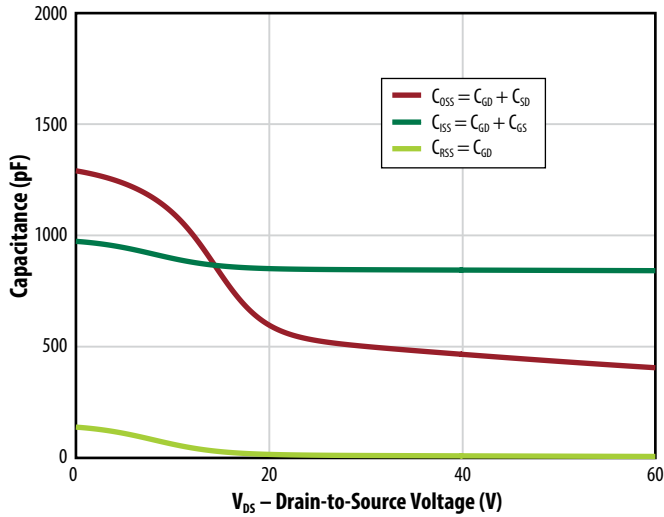
**Figure 3 (Q1 & Q2):**  
**Typical  $R_{DS(on)}$  vs.  $V_{GS}$  for Various Drain Currents**



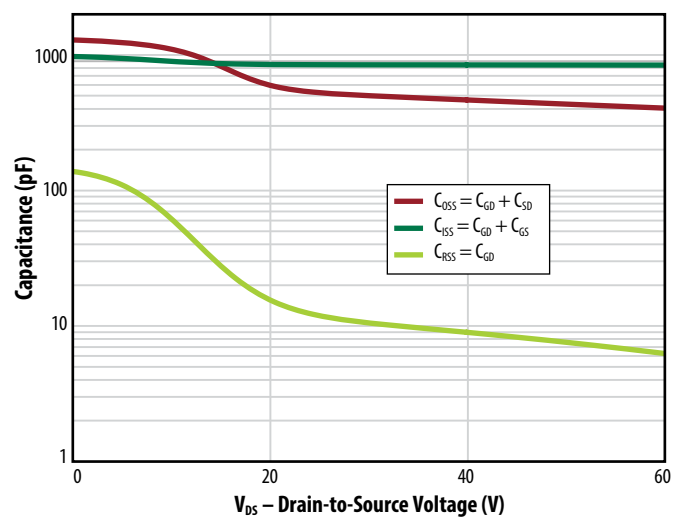
**Figure 4 (Q1 & Q2):**  
**Typical  $R_{DS(on)}$  vs.  $V_{GS}$  for Various Temperatures**



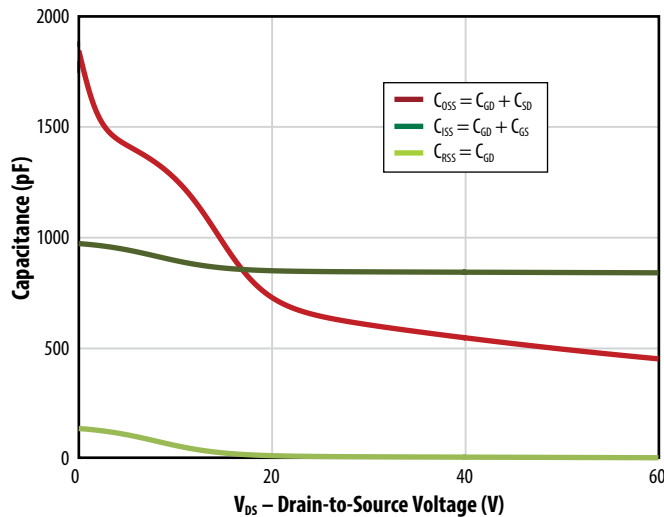
**Figure 5a (Q1): Typical Capacitance (Linear Scale)**



**Figure 5b (Q1): Typical Capacitance (Log Scale)**



**Figure 5c (Q2): Typical Capacitance (Linear Scale)**



**Figure 5d (Q2): Typical Capacitance (Log Scale)**

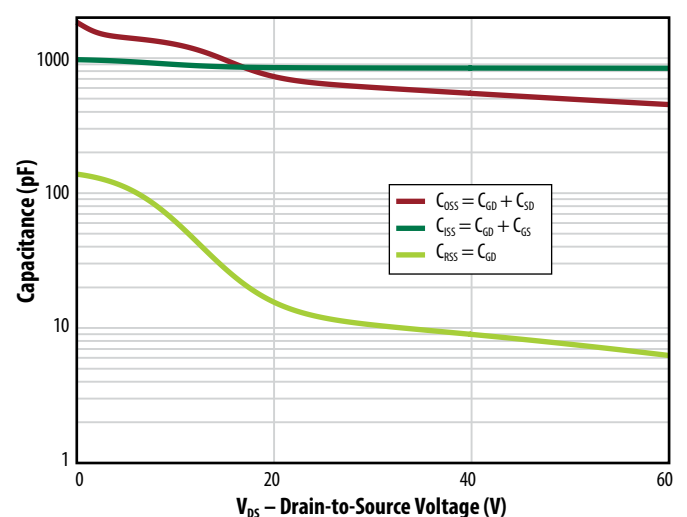


Figure 6a (Q1): Typical Output Charge and  $C_{OSS}$  Stored Energy

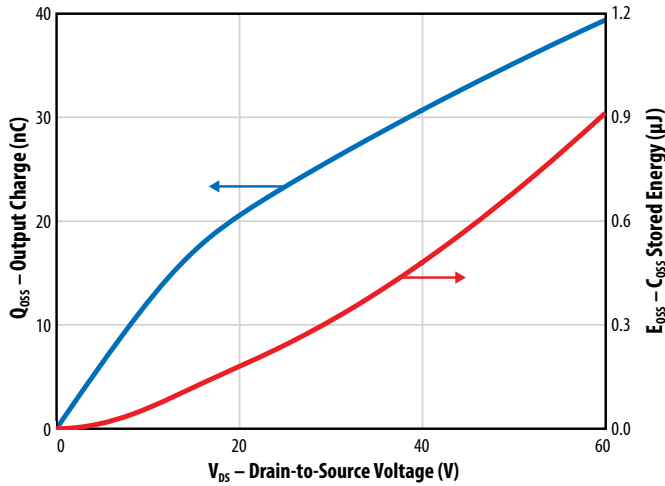


Figure 6b (Q2): Typical Output Charge and  $C_{OSS}$  Stored Energy

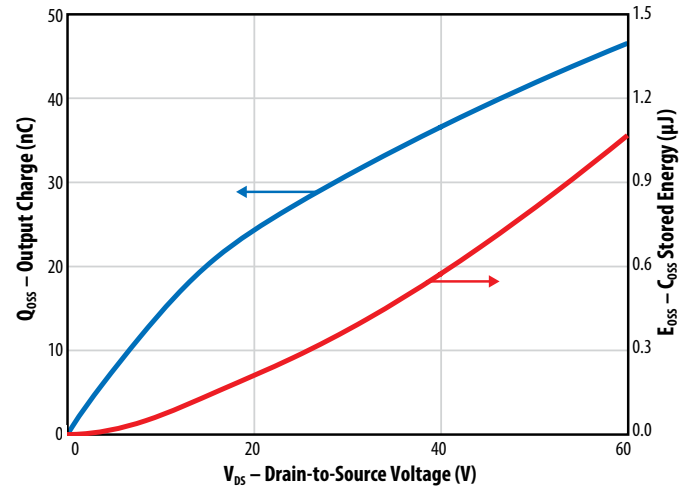


Figure 7 (Q1 & Q2): Typical Gate Charge

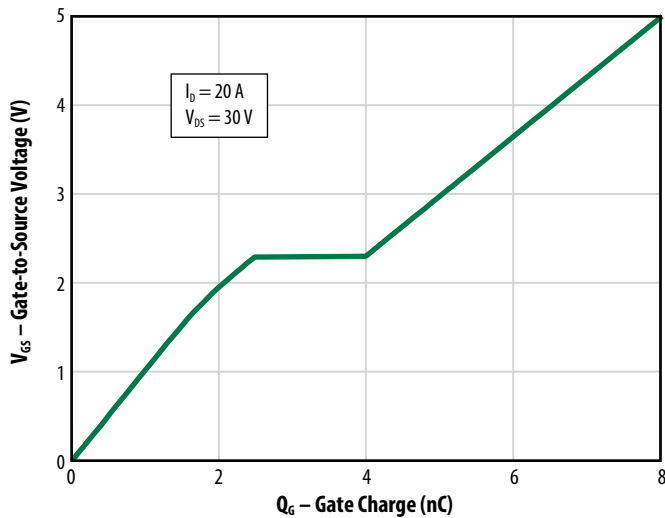
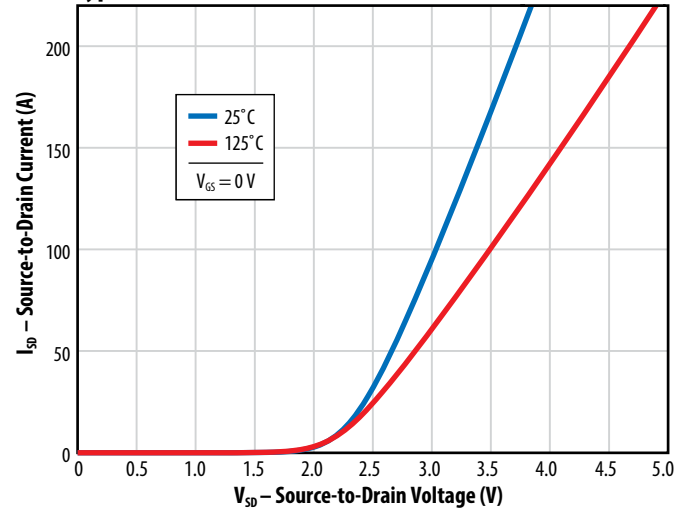


Figure 8 (Q1 & Q2): Typical Reverse Drain-Source Characteristics



Note: Negative gate drive voltage increases the reverse drain-source voltage. EPC recommends 0 V for OFF.

Figure 9 (Q1 & Q2): Typical Normalized On-State Resistance vs. Temperature

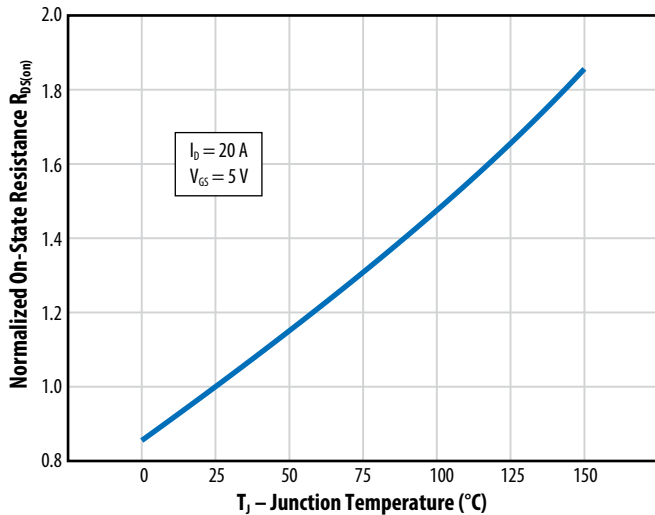
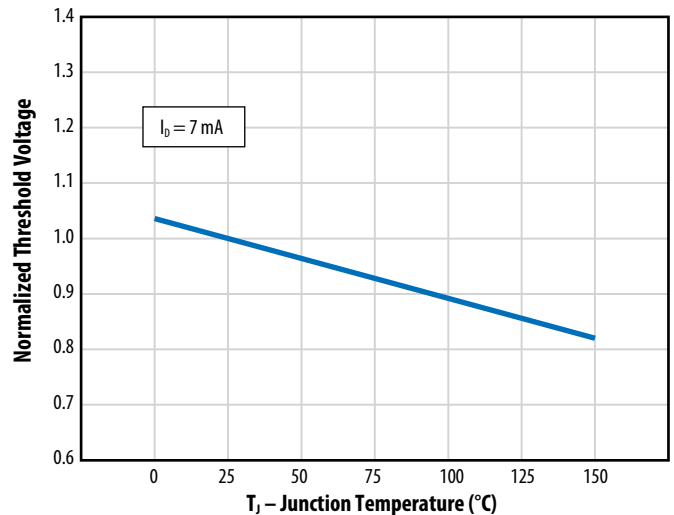
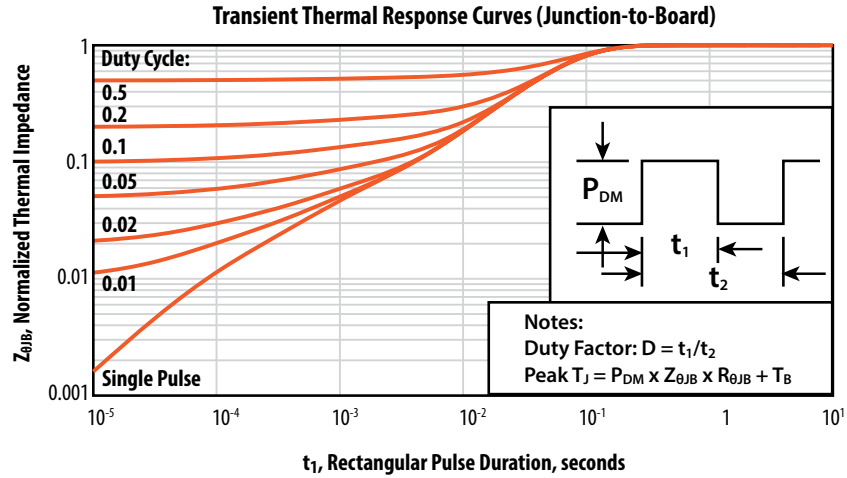


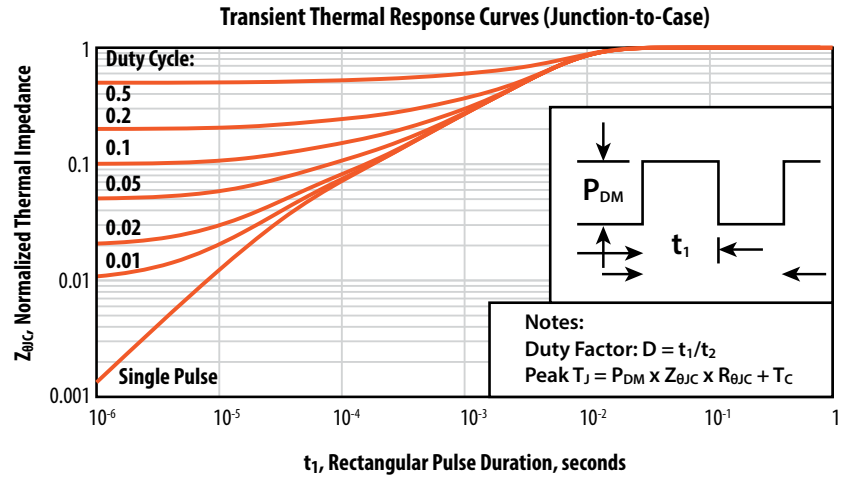
Figure 10 (Q1 & Q2): Typical Normalized Threshold Voltage vs. Temperature



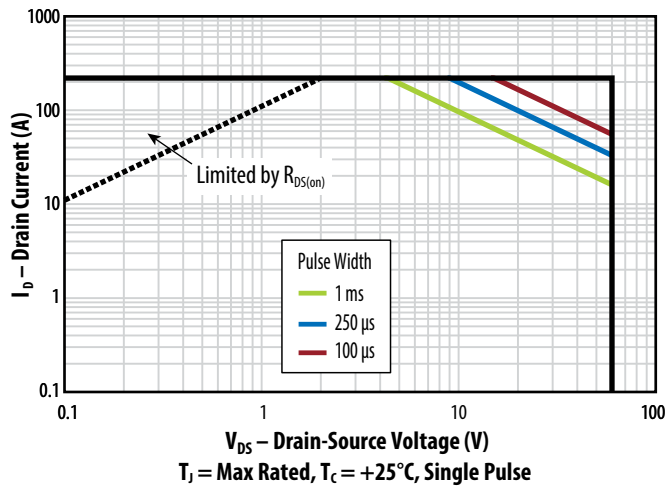
**Figure 11a**  
Typical Transient Thermal Response Curves



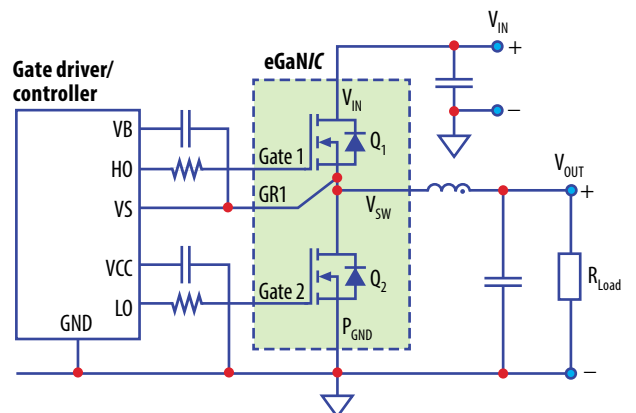
**Figure 11b**  
Typical Transient Thermal Response Curves



**Figure 12 (Q1 & Q2): Safe Operating Area**

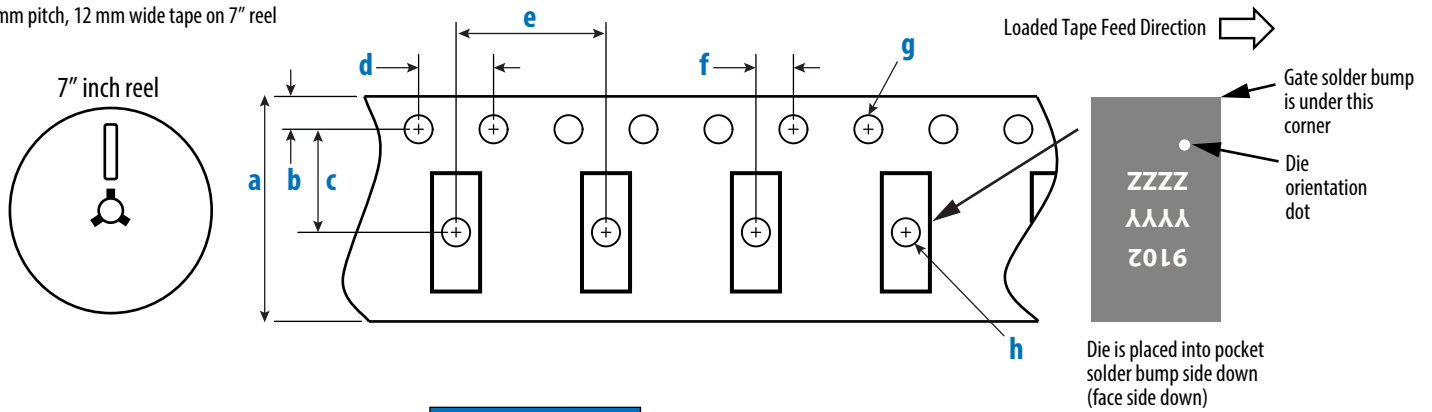


**Figure 13: Application Circuit**



**TAPE AND REEL CONFIGURATION**

8 mm pitch, 12 mm wide tape on 7" reel

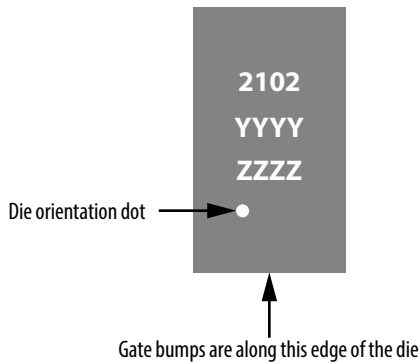


EPC2102 (Note 1)	Dimension (mm)		
	Target	MIN	MAX
<b>a</b>	12.00	11.90	12.30
<b>b</b>	1.75	1.65	1.85
<b>c</b> (Note 2)	5.50	5.45	5.55
<b>d</b>	4.00	3.90	4.10
<b>e</b>	8.00	7.90	8.10
<b>f</b> (Note 2)	2.00	1.95	2.05
<b>g</b>	1.50	1.50	1.60
<b>h</b>	1.50	1.50	1.75

Note 1: MSL 1 (moisture sensitivity level 1) classified according to IPC/JEDEC industry standard.

Note 2: Pocket position is relative to the sprocket hole measured as true position of the pocket, not the pocket hole.

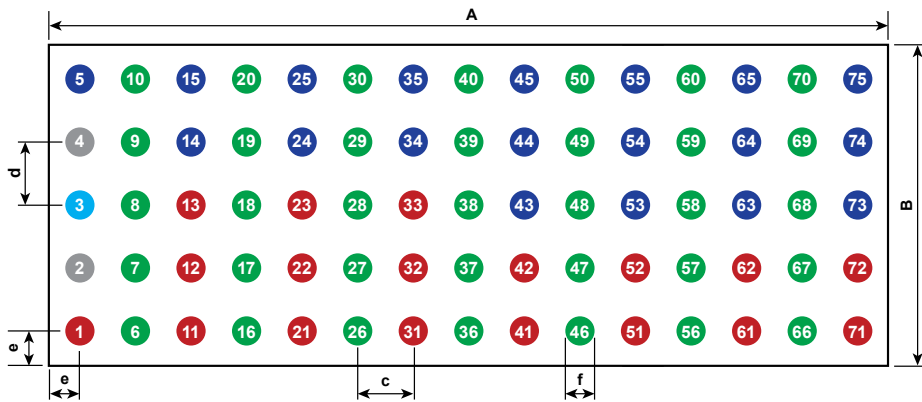
**DIE MARKINGS**



Part Number	Laser Markings		
	Part # Marking Line 1	Lot_Date Code Marking Line 2	Lot_Date Code Marking Line 3
EPC2102	2102	YYYY	ZZZZ

**DIE OUTLINE**

Solder Bump View



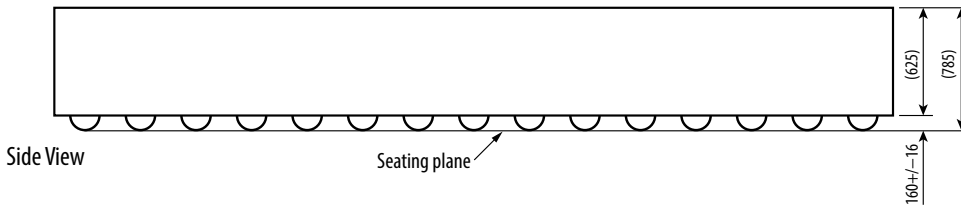
DIM	MIN	Nominal	MAX
A	6020	6050	6080
B	2270	2300	2330
c	400	400	400
d	450	450	450
e	210	225	240
f	187	208	229

Pad 2 is G1; Pad 3 is Q1 Gate Return; Pad 4 is G2;

Pads 1, 11, 12, 13, 21, 22, 23, 31, 32, 33, 41, 42, 51, 52, 61, 62, 71, 72 are  $V_{IN}$ ;

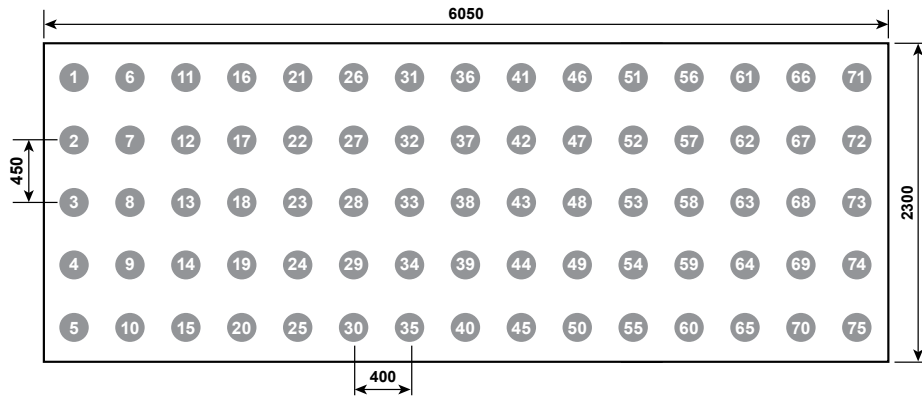
Pads 5, 14, 15, 24, 25, 34, 35, 43, 44, 45, 53, 54, 55, 63, 64, 65, 73, 74, 75 Ground;

Pads 6, 7, 8, 9, 10, 16, 17, 18, 19, 20, 26, 27, 28, 29, 30, 36, 37, 38, 39, 40, 46, 47, 48, 49, 50, 56, 57, 58, 59, 60, 66, 67, 68, 69, 70 are Switch Node



**RECOMMENDED LAND PATTERN**

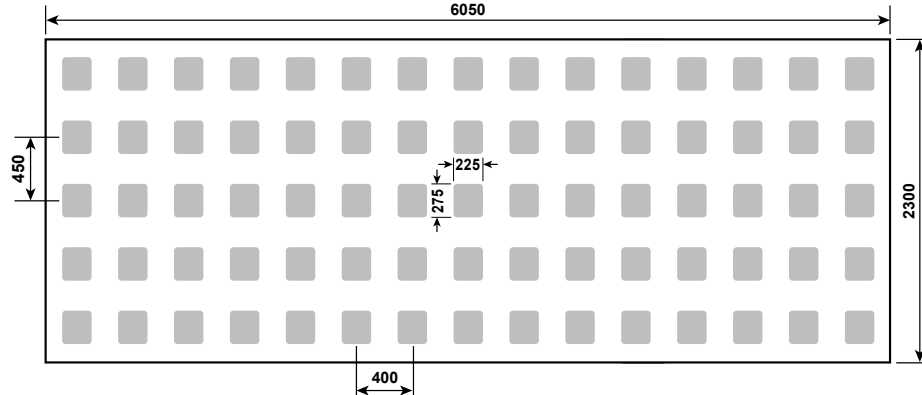
(measurements in  $\mu\text{m}$ )



The land pattern is solder mask defined.

**RECOMMENDED STENCIL DRAWING**

(measurements in  $\mu\text{m}$ )



Recommended stencil should be 4 mil (100  $\mu\text{m}$ ) thick, must be laser cut, openings per drawing.

Intended for use with SAC305 Type 4 solder, reference 88.5% metals content.

Additional assembly resources available at: <https://epc-co.com/epc/design-support>

Efficient Power Conversion Corporation (EPC) reserves the right to make changes without further notice to any products herein to improve reliability, function or design. EPC does not assume any liability arising out of the application or use of any product or circuit described herein; neither does it convey any license under its patent rights, nor the rights of others.

eGaN® is a registered trademark of Efficient Power Conversion Corporation.

EPC Patent Listing: <https://epc-co.com/epc/about-epc/patents>

Information subject to change without notice.