

COVERING

Mould-on polyurethane, hardness 92 Shore A.

WHEEL CENTRE BODY

Pressure die-cast aluminium.

ROLLING ACTION

Hub with ball bearings.
Ideal solution for heavy loads and continuous moving.

FIXED PLATE BRACKET

Yellow zinc-plated steel sheet. The bracket is designed to withstand loads up to 7500N.

It ensures capacities that make it suitable for heavy industrial applications.

TURNING PLATE BRACKET

Yellow zinc-plated steel sheet. The bracket is designed to withstand loads up to 7500N. It ensures capacities that make it suitable for heavy industrial applications.

It consists of (see Fig.1):

1. fitting plate: yellow zinc-plated steel sheet;
2. fork: yellow zinc-plated steel sheet;
3. ball race ring: yellow zinc-plated steel sheet;
4. central pin: class 8.8 steel screw and steel nut;
5. rotation system: dual grease-lubricated ball race;
6. dust seal: RAL 7015 dark grey technopolymer.

BRAKE

Front brake (RE.F5-125) or rear brake (RE.F5-150-200) dual-effect with simultaneous locking of wheel and bracket.

The brake is simple and effective to use: it is actuated and released by a simple action from the top downward at the tip of two separate pedals, thus ensuring the utmost manoeuvring comfort.

On wheels with a rear brake, the braking efficacy may be adjusted with a socket head screw M8.

STANDARD EXECUTIONS

- **PSL-H:**
fixed plate bracket, without brake.
- **SSL-H:**
turning plate bracket, without brake.
- **SSF-H:**
turning plate bracket, with brake.

APPLICATIONS

Excellent rolling resistance and elasticity features, high wear and tearing resistance.

For further information see wheel technical data sheet RE.F5 (see page 1251).

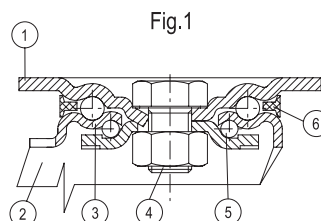

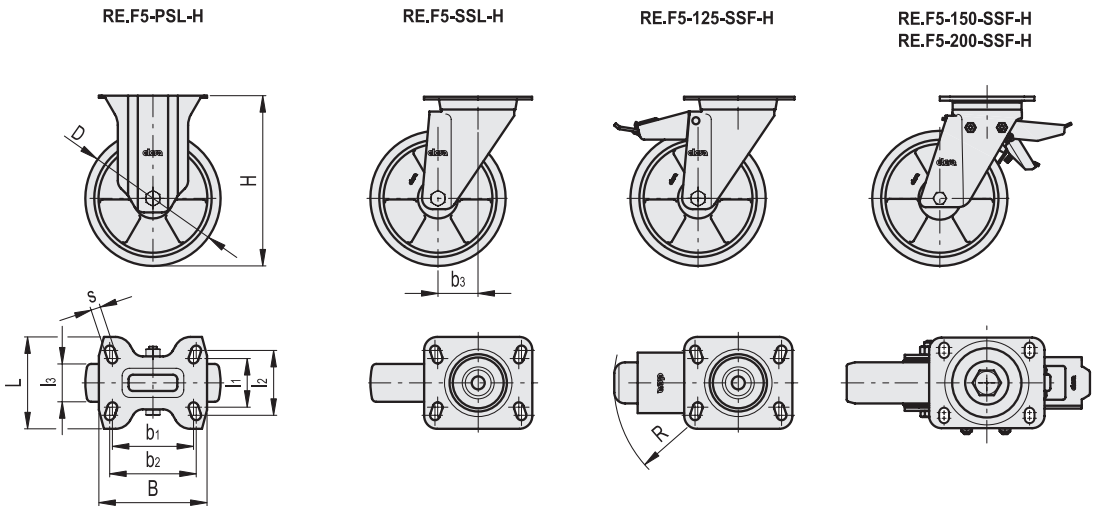

Conversion Table	
1 mm = 0.039 inch	
D	
mm	inch
125	4.92
150	5.91
200	7.87

RE.F5-PSL-H

Code	Description	D	I1	I2	I3	H	B	L	s	b1	b2	Rolling resistance# [N]	Dynamic carrying capacity# [N]	⚖️
451801	RE.F5-125-PSL-H	125	45	60	35	161	100	85	9	75	80	2800	3500	970
451806	RE.F5-150-PSL-H	150	73	85	40	200	140	115	11	105	105	3300	6000	2190
451811	RE.F5-200-PSL-H	200	73	85	50	250	140	115	11	105	105	3600	7500	2890

RE.F5-SSL-H

Code	Description	D	I1	I2	I3	H	B	L	s	b1	b2	b3	Rolling resistance# [N]	Dynamic carrying capacity# [N]	⚖️
451701	RE.F5-125-SSL-H	125	45	60	35	161	100	85	9	75	80	44	2800	3500	1390
451706	RE.F5-150-SSL-H	150	73	87	40	200	140	110	11	105	105	70	3300	6000	3180
451711	RE.F5-200-SSL-H	200	73	87	50	250	140	110	11	105	105	70	3600	7500	3780

RE.F5-SSF-H

Code	Description	D	I1	I2	I3	H	B	L	s	b1	b2	b3	R	Rolling resistance# [N]	Dynamic carrying capacity# [N]	⚖️
451751	RE.F5-125-SSF-H	125	45	60	35	161	100	85	9	75	80	44	123	2800	3500	1540
451756	RE.F5-150-SSF-H	150	73	87	40	200	140	110	11	105	105	70	126	3300	6000	3750
451761	RE.F5-200-SSF-H	200	73	87	50	250	140	110	11	105	105	70	126	3600	7500	4510

For rolling resistance and dynamic carrying capacity see Technical data (on page 1296).

