



1 MATERIAL

High-resilience polypropylene based (PP) technopolymer, black colour, matte finish.



2 BOSS CAP

Acetal resin based (POM) technopolymer, light grey colour, press-fit assembly.



STANDARD EXECUTIONS

Black-oxide steel boss, H7 reamed hole.

H9 reamed hole for executions with keyway.

- **VDS.**: without handle.
 - **VDS+I**: with revolving handle I.621+x (see page 406) in technopolymer.
 - **VDS+IEL**: with revolving handle IEL+x-SOFT (see page) in technopolymer coated with "Soft touch" thermoplastic elastomer (TPE).
 - **VDS+IR**: with fold-away handle IR.620 (see page 414) in technopolymer.
 - **VDS+IRS**: with safety fold-away handle IRS.820 (see page 416) in technopolymer.
- AISI 304 stainless steel boss, H7 reamed hole.
- **VDS-SST**: without handle.
 - **VDS+I-SST**: with revolving handle I.621+x-SST (see page 406) in technopolymer.
 - **VDS+IR-SST**: with fold-away handle IR.620-SST (see page 414) in technopolymer.
 - **VDS+IRS-SST**: with safety fold-away handle IRS.820-SST (see page 416) in technopolymer.

K: index for executions with hole and keyway in compliance with DIN 6885/1 (see page A-16), tolerance P9 i.e.:

72641-R-K VDS.80-A-8-K



ACCESSORIES ON REQUEST

- GN 184: axial retaining washer in black-oxide steel (see page 897).
- GN 184.5: axial retaining washer in AISI 303 stainless steel (see page 897).
- ECB.D: glass-fibre reinforced polyamide based (PA) technopolymer boss cap, in Elecolors colours, matte finish, press-fit assembly, available for VDS.125, VDS.150 and VDS.175 (see table).



C1	C2	C3	C4	C5	C6
RAL7021	RAL2004	RAL7035	RAL1021	RAL5024	RAL3000



ECB.D

Code	Description	Boss cap for
29582-*	ECB.D2-*	VDS.125
29583-*	ECB.D3-*	VDS.150
29584-*	ECB.D4-*	VDS.175

* Complete with colour index (C1, ..., C6).



ELESA Original design

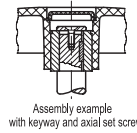

Assembly example with keyway and axial set screw

Conversion Table	
1 mm = 0.039 inch	
D	
mm	inch
83	3.27
102	4.02
125	4.92
150	5.91
176	6.93
200	7.87
250	9.84
300	11.81

**VDS.
VDS-SST**

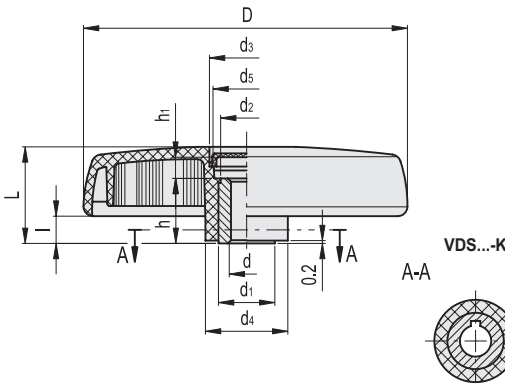

**VDS+I
VDS+I-SST**

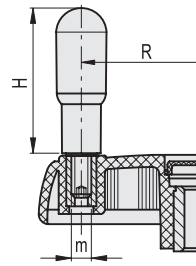

VDS+IEL

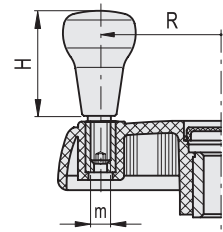

VDS. **METRIC**

Code*	Description*	D	dH7	L	d1	d2	d3	d4	d5	l	h	h1	C# [Nm]	L# [J]	
72641-R	VDS.80-A-8	83	8	29	18	16	21	26	19	9	17	8	34	6	84
72642-R	VDS.80-A-10	83	10	29	18	16	21	26	19	9	17	8	34	6	86
72660-R	VDS.100 A-8	102	8	34	22	20	27	30	25	10	22	9	60	13	145
72661-R	VDS.100 A-10	102	10	34	22	20	27	30	25	10	22	9	60	13	140
72662-R	VDS.100 A-12	102	12	34	22	20	27	30	25	10	22	9	60	13	135
72740-R	VDS.150 A-8	150	8	44	26	24	34	38	30	12	30	10	180	26	335
72741-R	VDS.150 A-14	150	14	44	26	24	34	38	30	12	30	10	180	26	315
72840-R	VDS.200 A-8	200	8	53	40	38	44	50	40	14	36	13	320	27	620
72841-R	VDS.200 A-20	200	20	53	40	38	44	50	40	14	36	13	320	27	590

VDS-SST **INOX STAINLESS STEEL METRIC**

Code*	Description*	D	dH7	L	d1	d2	d3	d4	d5	l	h	h1	C# [Nm]	L# [J]	
72665-R	VDS.100-SST-10	102	10	34	22	20	27	30	25	10	22	9	60	13	141
72745-R	VDS.150-SST-14	150	14	44	26	24	34	38	30	12	30	10	180	26	318
72845-R	VDS.200-SST-20	200	20	53	40	38	44	50	40	14	36	13	320	27	596

VDS+I **METRIC**

Code*	Description*	D	dH7	L	d1	d2	d3	d4	d5	l	h	h1	H	m	R	C# [Nm]	L# [J]	
72651-R	VDS.80+I A-8	83	8	29	18	16	21	26	19	9	17	8	45	M6	30.5	34	6	106
72652-R	VDS.80+I A-10	83	10	29	18	16	21	26	19	9	17	8	45	M6	30.5	34	6	108
72670-R	VDS.100+I A-8	102	8	34	22	20	27	30	25	10	22	9	60	M6	38	60	13	180
72671-R	VDS.100+I A-10	102	10	34	22	20	27	30	25	10	22	9	60	M6	38	60	13	174
72672-R	VDS.100+I A-12	102	12	34	22	20	27	30	25	10	22	9	60	M6	38	60	13	168
72700-R	VDS.125+I A-8	125	8	39.5	26	24	31	35	28	11	27	11	60	M6	49	125	25	282
72701-R	VDS.125+I A-12	125	12	39.5	26	24	31	35	28	11	27	11	60	M6	49	125	25	270
72702-R	VDS.125+I A-14	125	14	39.5	26	24	31	35	28	11	27	11	60	M6	49	125	25	258
72750-R	VDS.150+I A-8	150	8	44	26	24	34	38	30	12	30	10	65	M8	56.5	180	26	399
72751-R	VDS.150+I A-14	150	14	44	26	24	34	38	30	12	30	10	65	M8	56.5	180	26	379
72752-R	VDS.150+I A-16	150	16	44	26	24	34	38	30	12	30	10	65	M8	56.5	180	26	359
72800-R	VDS.175+I A-8	176	8	49	35	33	39	44	35	12	28	16	80	M10	70	195	26	530
72801-R	VDS.175+I A-16	176	16	49	35	33	39	44	35	12	28	16	80	M10	70	195	26	500
72802-R	VDS.175+I A-20	176	20	49	35	33	39	44	35	12	28	16	80	M10	70	195	26	470
72850-R	VDS.200+I A-8	200	8	53	40	38	44	50	40	14	36	13	90	M10	81	320	27	714
72851-R	VDS.200+I A-20	200	20	53	40	38	44	50	40	14	36	13	90	M10	81	320	27	674
72852-R	VDS.200+I A-24	200	24	53	40	38	44	50	40	14	36	13	90	M10	81	320	27	634
72911-R	VDS.250+I A-20	250	20	60	40	38	50	57	48	17	36	19	90	M10	104	500	30	934
72961-R	VDS.300+I A-20	300	20	66	40	36.5	68.5	72	66	20	44	20	90	M10	124	500	30	1260

VDS+I-SST **INOX STAINLESS STEEL METRIC**

Code*	Description*	D	dH7	L	d1	d2	d3	d4	d5	l	h	h1	H	m	R	C# [Nm]	L# [J]	
72675-R	VDS.100+I-SST-10	102	10	34	22	20	27	30	25	10	22	9	60	M6	38	60	13	175
72705-R	VDS.125+I-SST-12	125	12	42	26	24	31	35	28	11	27	11	60	M6	49	125	25	273
72755-R	VDS.150+I-SST-14	150	14	44	26	24	34	38	30	12	30	10	65	M8	56.5	180	26	383
72855-R	VDS.200+I-SST-20	200	20	53	40	38	44	50	40	14	36	13	90	M10	81	320	27	681

VDS+IEL **METRIC**

Code*	Description*	D	dH7	L	d1	d2	d3	d4	d5	l	h	h1	H	m	R	C# [Nm]	L# [J]	
72966-R	VDS.300+IEL A-20	300	20	66	40	36.5	68.5	72	66	20	44	20	65	M10	124	500	30	1270

* To order the execution with hole and keyway add the index -K after the code and description (i.e. 72641-R-K VDS.80-A-8-K).
For maximum torque (C) and impact strength (L) see Technical data on page A-3.



Operating elements

- 1
- 2
- 3
- 4
- 5
- 6
- 7
- 8
- 9
- 10
- 11
- 12
- 13
- 14
- 15
- 16
- 17
- 18

VDS+IR
VDS+IR-SST

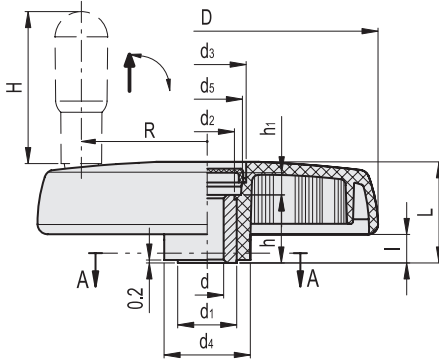

VDS+IRS
VDS+IRS-SST

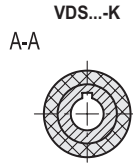
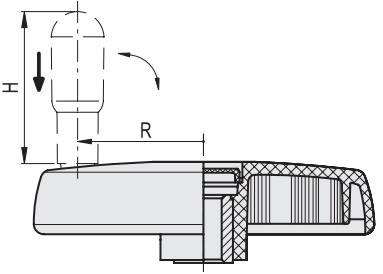

VDS+IR

METRIC

Code*	Description*	D	dH7	L	d1	d2	d3	d4	d5	l	h	h1	H	R	C# [Nm]	L# [J]	
72656-R	VDS.80+IR A-8	83	8	38	18	16	16.5	25	13.5	18.5	17	3.5	45	28	34	6	133
72657-R	VDS.80+IR A-10	83	10	38	18	16	16.5	25	13.5	18.5	17	3.5	45	28	34	6	129
72680-R	VDS.100+IR A-8	102	8	34	22	20	27	30	25	10	22	9	45	38	60	14	177
72681-R	VDS.100+IR A-10	102	10	34	22	20	27	30	25	10	22	9	45	38	60	14	170
72682-R	VDS.100+IR A-12	102	12	34	22	20	27	30	25	10	22	9	45	38	60	14	163
72683-R	VDS.100+IR A-14	102	14	34	22	20	27	30	25	10	22	9	45	38	60	14	158
72710-R	VDS.125+IR A-8	125	8	39.5	26	24	31	35	28	11	27	11	60	49	125	14	311
72711-R	VDS.125+IR A-12	125	12	39.5	26	24	31	35	28	11	27	11	60	49	125	14	307
72712-R	VDS.125+IR A-14	125	14	39.5	26	24	31	35	28	11	27	11	60	49	125	14	303
72760-R	VDS.150+IR A-8	150	8	44	26	24	34	38	30	12	30	10	65	56.5	180	15	450
72761-R	VDS.150+IR A-14	150	14	44	26	24	34	38	30	12	30	10	65	56.5	180	15	432
72762-R	VDS.150+IR A-16	150	16	44	26	24	34	38	30	12	30	10	65	56.5	180	15	415
72810-R	VDS.175+IR A-8	176	8	49	35	33	39	44	35	12	28	16	80	70	195	20	588
72811-R	VDS.175+IR A-16	176	16	49	35	33	39	44	35	12	28	16	80	70	195	20	577
72812-R	VDS.175+IR A-20	176	20	49	35	33	39	44	35	12	28	16	80	70	195	20	565
72860-R	VDS.200+IR A-8	200	8	53	40	38	44	50	40	14	36	13	90	81	320	27	750
72861-R	VDS.200+IR A-20	200	20	53	40	38	44	50	40	14	36	13	90	81	320	27	710
72862-R	VDS.200+IR A-24	200	24	53	40	38	44	50	40	14	36	13	90	81	320	27	670
72921-R	VDS.250+IR A-20	250	20	60	40	38	50	57	48	17	36	19	90	104	500	30	997
72971-R	VDS.300+IR A-20	300	20	66	40	36.5	68.5	72	66	20	44	20	90	124	500	30	1375

VDS+IR-SST

INOX STAINLESS STEEL METRIC

72685-R	VDS.100+IR-SST-10	102	10	34	22	20	27	30	25	10	22	9	45	38	60	14	171
72715-R	VDS.125+IR-SST-12	125	12	42	26	24	31	35	28	11	27	11	60	49	125	14	310
72765-R	VDS.150+IR-SST-14	150	14	44	26	24	34	38	30	12	30	10	65	56.5	180	15	436
72865-R	VDS.200+IR-SST-20	200	20	53	40	38	44	50	40	14	36	13	90	81	320	27	717

VDS+IRS

METRIC

Code*	Description*	D	dH7	L	d1	d2	d3	d4	d5	l	h	h1	H	R	C# [Nm]	L# [J]	
72770-R	VDS.150+IRS A-8	150	8	44	26	24	34	38	30	12	30	10	65	56.5	180	15	455
72771-R	VDS.150+IRS A-14	150	14	44	26	24	34	38	30	12	30	10	65	56.5	180	15	445
72772-R	VDS.150+IRS A-16	150	16	44	26	24	34	38	30	12	30	10	65	56.5	180	15	435
72820-R	VDS.175+IRS A-8	176	8	49	35	33	39	44	35	12	28	16	80	70	195	20	590
72821-R	VDS.175+IRS A-16	176	16	49	35	33	39	44	35	12	28	16	80	70	195	20	580
72822-R	VDS.175+IRS A-20	176	20	49	35	33	39	44	35	12	28	16	80	70	195	20	570
72870-R	VDS.200+IRS A-8	200	8	53	40	38	44	50	40	14	36	13	90	81	320	27	770
72871-R	VDS.200+IRS A-20	200	20	53	40	38	44	50	40	14	36	13	90	81	320	27	730
72872-R	VDS.200+IRS A-24	200	24	53	40	38	44	50	40	14	36	13	90	81	320	27	690
72931-R	VDS.250+IRS A-20	250	20	60	40	38	50	57	48	17	36	19	90	104	500	30	955
72981-R	VDS.300+IRS A-20	300	20	66	40	36.5	68.5	72	66	20	44	20	90	124	500	30	1285

VDS+IRS-SST

INOX STAINLESS STEEL METRIC

72775-R	VDS.150+IRS-SST-14	150	14	44	26	24	34	38	30	12	30	10	65	56.5	180	15	450
72875-R	VDS.200+IRS-SST-20	200	20	53	40	38	44	50	40	14	36	13	90	81	320	27	737

* To order the execution with hole and keyway add the index -K after the code and description (i.e. 72641-R-K VDS.80-A-8-K).

For maximum torque (C) and impact strength (L) see Technical data on page A-3.