



- 1
- 2
- 3
- 4
- 5
- 6
- 7
- 8
- 9
- 10
- 11
- 12
- 13
- 14
- 15
- 16
- 17
- 18
- 19

**MATERIAL**

Glass-fibre reinforced polyamide based (PA) technopolymer, black colour, matte finish.

VB.639/130: glass-fibre reinforced polypropylene based (PP) technopolymer, black colour, matte finish.

**STANDARD EXECUTIONS**

- **VB.639-A:** black-oxide steel boss, plain blind hole.
- **VB.639-B:** brass boss, threaded blind hole.
- **VB.639-FP:** brass boss, threaded pass-through hole.
- **VB.639-p:** zinc-plated steel threaded stud with chamfered flat end as in UNI 947 : ISO 4753 (see Technical data on page A-11).
- **VB.639-SST:** AISI 303 stainless steel boss, threaded blind hole.
- **VB.639-FP-SST:** AISI 303 stainless steel, threaded pass-through hole.

**APPLICATIONS**

This knob has been designed for heavy duty work where the use of a hammer for a firmer clamping action is required.



ELESA Original design

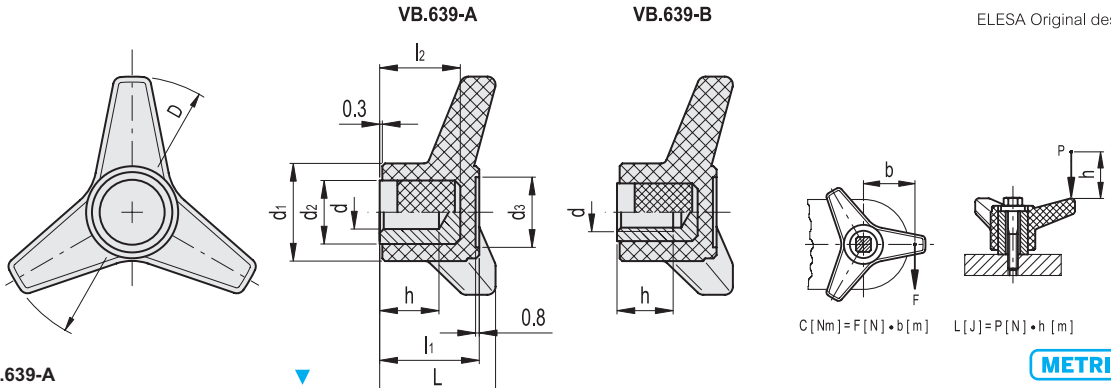

**VB.639-A**

Code	Description	D	dH9	L	d1	d2	d3	l1	l2	h	C# [Nm]	L* [J]	$\Delta$
65531	VB.639/45 A-6	45	6	25	19	12	12	22.5	17	14	11	2	40
65631	VB.639/63 A-6	63	6	28	26	15	18	25	23	18	30	7	55
65672	VB.639/80 A-8	80	8	35	32	15	21	30	25	20	80	6	75
65702	VB.639/100 A-10	100	10	42	35	20	25	36	25	21	110	8	130
65742	VB.639/130 A-12	130	12	47	43	20	29	40	31	24	135	9	180



**VB.639-B**

Code	Description	D	d6H	L	d1	d3	l1	h	C# [Nm]	L* [J]	$\Delta$
65541	VB.639/45 B-M6	45	M6	25	19	12	22.5	12	11	2	33
65545	VB.639/45 B-M8	45	M8	25	19	12	22.5	13	11	2	30
65635	VB.639/63 B-M8	63	M8	28	26	18	25	15	30	7	48
65636	VB.639/63 B-M10	63	M10	28	26	18	25	17	30	7	40
65674	VB.639/80 B-M8	80	M8	35	32	17	30	15	80	6	64
65675	VB.639/80 B-M10	80	M10	35	32	21	30	17	80	6	60
65676	VB.639/80 B-M12	80	M12	35	32	21	30	17	80	6	67
65705	VB.639/100 B-M12	100	M12	42	35	25	36	20	110	8	96
65706	VB.639/100 B-M14	100	M14	42	35	25	36	20	110	8	105
65745	VB.639/130 B-M16	130	M16	47	43	29	40	22	135	9	150
65746	VB.639/130 B-M20	130	M20	47	43	29	40	25	135	9	151



# "Max limit Tightening torque" means the max torque value at which the metal insert, in normal conditions of use, is perfectly and strongly anchored to the plastic material.

\* For impact strength (L) see Technical data on page A-3.

Clamping elements

Conversion Table	
1 mm = 0.039 inch	
D	
mm	inch
45	1.77
63	2.48
80	3.15
100	3.94
130	5.12

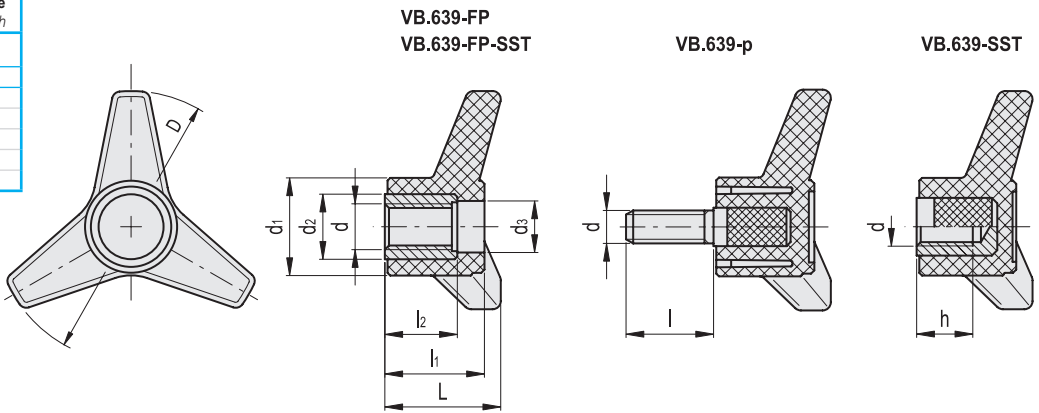

VB.639-FP

METRIC

Code	Description	D	d6H	L	d1	d2	d3	l1	l2	C# [Nm]	L* [J]	⚖️
65551	VB.639/45 FP-M6	45	M6	25	19	8	9	22.5	12	11	2	30
65555	VB.639/45 FP-M8	45	M8	25	19	11	10	22.5	12	11	2	27
65641	VB.639/63 FP-M10	63	M10	28	27	16	13	25	21	30	7	47
65642	VB.639/63 FP-M12	63	M12	28	27	16	13	25	21	30	7	50
65680	VB.639/80-FP-M8	80	M8	35	32	18	17	30	25	80	7	80
65682	VB.639/80-FP-M10	80	M10	35	32	18	17	30	25	80	7	71
65681	VB.639/80 FP-M12	80	M12	35	32	18	17	30	25	80	7	77
65711	VB.639/100 FP-M16	100	M16	42	35	20	20	37	31	110	8	105
65751	VB.639/130 FP-M16	130	M16	47	43	24	22	40	34	135	9	157

VB.639-p

METRIC

Code	Description	D	d6g	L	d1	d3	l	l1	C# [Nm]	L* [J]	⚖️
65561	VB.639/45 p-M6x20	45	M6	25	19	12	20	22.5	10	2	29
65565	VB.639/45 p-M8x25	45	M8	25	19	12	25	22.5	23	2	31
65652	VB.639/63 p-M8x25	63	M8	28	26	18	25	25	25	7	44
65692	VB.639/80 p-M10x30	80	M10	35	32	21	30	30	50	7	78
65722	VB.639/100 p-M12x40	100	M12	42	35	25	40	36	110	8	126

VB.639-SST

INOX STAINLESS STEEL

METRIC

Code	Description	D	d6H	L	d1	d3	l1	h	C# [Nm]	L* [J]	⚖️
65548	VB.639/45 SST-M6	45	M6	25	19	12	22.5	12	11	2	34
65638	VB.639/63-SST-M8	63	M8	28	26	18	25	15	30	7	49
65677	VB.639/80-SST-M8	80	M8	35	32	17	30	20	80	6	65
65678	VB.639/80-SST-M10	80	M10	35	32	21	30	17	80	6	61
65679	VB.639/80-SST-M12	80	M12	35	32	17	30	17	80	6	68
65708	VB.639/100-SST-M12	100	M12	42	35	25	36	20	110	8	97
65748	VB.639/130-SST-M16	130	M16	47	43	29	40	22	135	9	164

VB.639-FP-SST

INOX STAINLESS STEEL

METRIC

Code	Description	D	d6H	L	d1	d2	d3	l1	l2	C# [Nm]	L* [J]	⚖️
65685	VB.639/80-FP-SST-M8	80	M8	35	32	18	17	30	25	80	6	81
65686	VB.639/80-FP-SST-M10	80	M10	35	32	18	17	30	25	80	6	72
65687	VB.639/80-FP-SST-M12	80	M12	35	32	18	17	30	25	80	6	78

# "Max limit Tightening torque" means the max torque value at which the metal insert, in normal conditions of use, is perfectly and strongly anchored to the plastic material.

\* For impact strength (L) see Technical data on page A-3.

