

- 1
- 2
- 3
- 4
- 5
- 6
- 7
- 8
- 9
- 10
- 11
- 12
- 13
- 14
- 15
- 16
- 17
- 18
- 19

MATERIAL

Die-cast zinc alloy.

ROTATING PIN

AISI 303 stainless steel.

STANDARD EXECUTIONS



- **CMM-SH**: black painting, matte finish, pass-through holes for countersunk head screws.
- **CMM-SH-CR**: chrome-plated finish, pass-through holes for countersunk head screws.
- **CMM-p**: black painting, matte finish, AISI 304 stainless steel threaded studs.
- **CMM-p-CR**: chrome-plated finish, AISI 316 stainless steel threaded studs.

ROTATION ANGLE (APPROXIMATE VALUE)

Max 270° (-90° and +180° being 0° the condition where the two interconnected surfaces are on the same plane).

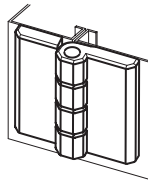
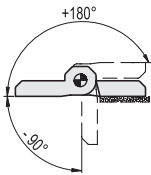
Do not exceed the rotation angle limit so as not to prejudice the hinge mechanical performance.

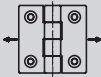

Resistance tests	Axial Stress	Radial Stress	90° Angled Stress
	 Maximum working load Ea [N]	 Maximum working load Er [N]	 Maximum working load E90 [N]
Description			
CMM.30-SH-4	500	1200	750
CMM.40-SH-5	1450	2100	2000
CMM.50-SH-6	2100	3500	2450
CMM.60-SH-8	3200	6000	4400
CMM.40-p-M5x12	900	1700	1850
CMM.50-p-M6x12	2050	3550	2000
CMM.60-p-M8x14	3050	4050	2550

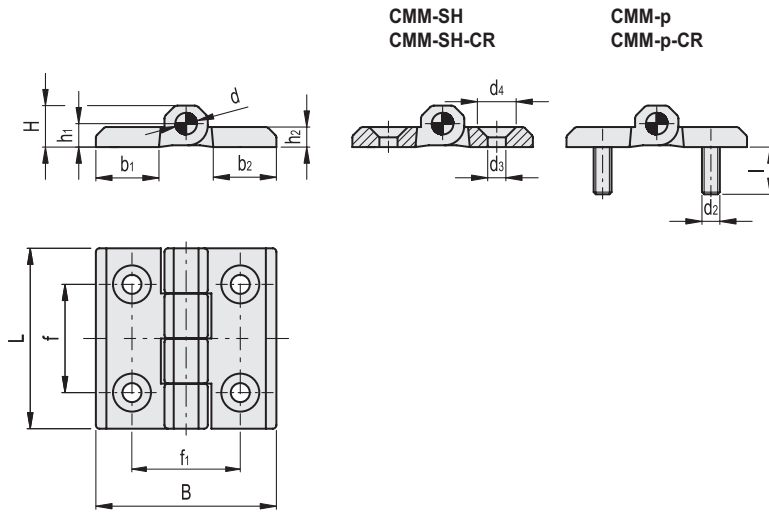

CMM-SH

Code	Description	L	B	d3	d4	f	f1	H	h1	h2	b1	b2	d	⚖️
428411	CMM.30-SH-4	30	30	4.6	9.5	18	18	7.5	4.5	4	11	11	3	20
428511	CMM.40-SH-5	40	40	5.3	10.5	25	25	9	5.5	5	14	14	4	40
428611	CMM.50-SH-6	50	50	6.4	12.5	30	30	11.5	6.5	6	18.5	18.5	6	80
428711	CMM.60-SH-8	60	60	8.3	16.5	36	36	15	8.5	8	21.5	21.5	8	170

CMM-SH-CR

Code	Description	L	B	d3	d4	f	f1	H	h1	h2	b1	b2	d	⚖️
428414	CMM.30-SH-4-CR	30	30	4.6	9.5	18	18	7.5	4.5	4	11	11	3	20
428514	CMM.40-SH-5-CR	40	40	5.3	10.5	25	25	9	5.5	5	14	14	4	40
428614	CMM.50-SH-6-CR	50	50	6.4	12.5	30	30	11.5	6.5	6	18.5	18.5	6	80
428714	CMM.60-SH-8-CR	60	60	8.3	16.5	36	36	15	8.5	8	21.5	21.5	8	170

CMM-p

Code	Description	L	B	d2	l	f	f1	H	h1	h2	b1	b2	d	⚖️
428521	CMM.40-p-M5x12	40	40	M5	12	25	25	9	5.5	5	14	14	4	63
428621	CMM.50-p-M6x12	50	50	M6	12	30	30	11.5	6.5	6	18	18	6	100
428721	CMM.60-p-M8x12	60	60	M8	12	36	36	15	8.5	8	21	21	8	210

CMM-p-CR

Code	Description	L	B	d2	l	f	f1	H	h1	h2	b1	b2	d	⚖️
428524	CMM.40-p-M5x12-CR	40	40	M5	12	25	25	9	5.5	5	14	14	4	63
428624	CMM.50-p-M6x12-CR	50	50	M6	12	30	30	11.5	6.5	6	18	18	6	100
428724	CMM.60-p-M8x14-CR	60	60	M8	14	36	36	15	8.5	8	21	21	8	210