

- 1
- 2
- 3
- 4
- 5
- 6
- 7
- 8
- 9
- 10
- 11
- 12
- 13
- 14
- 15
- 16
- 17
- 18
- 19

MATERIAL

High-resilience polyamide based (PA) technopolymer, black colour, matte finish.

ROTATING PIN

AISI 303 stainless steel.

STANDARD EXECUTIONS

- **CFD-B**: nickel-plated brass bosses with threaded hole.
- **CFD-p**: nickel-plated brass threaded studs in the wide body, nickel-plated steel threaded studs in the narrow body.
- **CFD-p-B**: nickel-plated brass threaded studs and nickel-plated brass bosses with threaded hole.
- **CFD-B-p**: nickel-plated brass bosses with threaded hole and nickel-plated steel threaded studs.
- **CFD-CH-B**: pass-through holes for cylindrical head screws and nickel-plated brass bosses with threaded hole.
- **CFD-CH-p**: pass-through holes for cylindrical head screws and nickel-plated steel threaded studs.

FEATURES AND APPLICATIONS

The hinge is made up of two bodies with different dimensions (a narrow one and a larger one) and can be assembled for example on structures with thin frame or door.

ROTATION ANGLE (APPROXIMATE VALUE)

Max 205° (-15° and +190° being 0° the condition where the two interconnected surfaces are on the same plane).

Do not exceed the rotation angle limit so as not to prejudice the hinge mechanical performance.

To choose the convenient type and the right number of hinges for your application, see the Guidelines (see page 952).

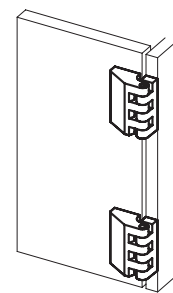
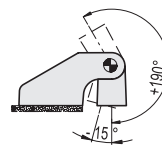

FMdesign

Description	Axial Stress		Radial Stress		90° Angled Stress	
	Maximum working load Ea [N]	Load at breakage Ra [N]	Maximum working load Er [N]	Load at breakage Rr [N]	Maximum working load E90 [N]	Load at breakage R90 [N]
CFD.30 B-M3	60	690	70	490	60	500
CFD.30 p-M3x13	70	750	40	340	30	390
CFD.30 p-M3x13-B-M3	60	690	40	340	30	390
CFD.30 B-M3-p-M3x13	60	690	40	340	30	390
CFD.30 CH-3-B-M3	100	830	110	720	70	670
CFD.30 CH-3-p-M3x13	60	730	50	450	30	350
CFD.40 B-M4	160	1710	150	1340	100	700
CFD.40 p-M4x18	110	1230	140	880	50	730
CFD.40 p-M4x18-B-M4	110	1230	140	880	50	700
CFD.40 B-M4-p-M4x18	110	1230	140	880	50	700
CFD.40 CH-4-B-M4	120	1620	150	1220	130	1110
CFD.40 CH-4-p-M4x18	150	1480	140	820	100	860
CFD.48 B-M5	260	2440	260	1700	120	1640
CFD.48 p-M5x17	290	1770	240	1840	110	1740
CFD.48 p-M5x17-B-M5	260	1770	240	1700	110	1640
CFD.48 B-M5-p-M5x17	260	1770	240	1700	110	1640
CFD.48 CH-5-B-M5	330	2530	240	1890	290	1870
CFD.48 CH-5-p-M5x17	150	2170	120	1200	110	970
CFD.66 B-M6	450	4130	320	2520	220	2250
CFD.66 p-M6x16	470	3260	260	1700	240	1580
CFD.66 p-M6x16-B-M6	450	3260	260	1700	220	1580
CFD.66 B-M6-p-M6x16	450	3260	260	1700	220	1580
CFD.66 CH-6-B-M6	430	3660	410	2610	310	2830
CFD.66 CH-6-p-M6x16	350	3090	280	1770	180	1610

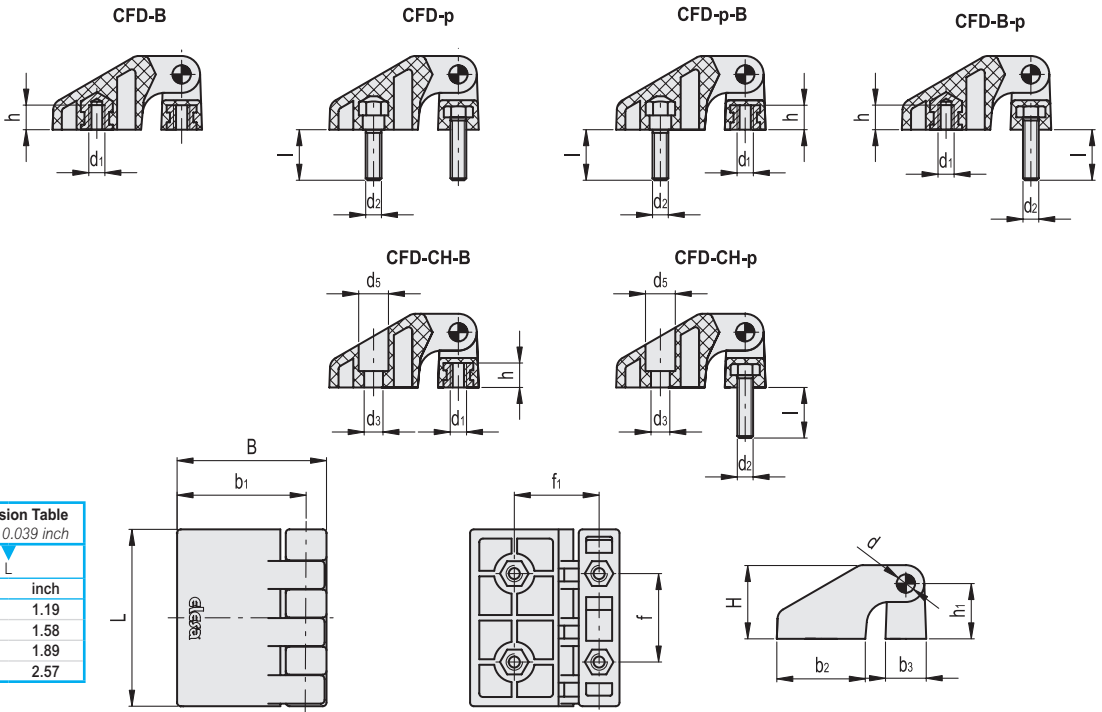

CFD-B

Code	Description	L	B	d1	h	f _{±0.25}	f1 ±0.25	H	h1	b1	b2	b3	d	d1	C [Nm]	B#	⚖️
422711	CFD.30 B-M3	30.5	26.5	M3	4	15	15	12.5	9.5	22.5	15	7	2.5	M3	1	10	
422811	CFD.40 B-M4	40.5	34	M4	5.5	20	20.2	16.5	12.5	29.5	20	9.5	4	M4	4	22	
422911	CFD.48 B-M5	48.5	40.5	M5	6.5	24	23	20	15	35	24	11.5	5	M5	5	37	
423011	CFD.66 B-M6	66	56	M6	9	33	31.8	27.5	21	48.5	33	15	6	M6	5	86	

METRIC

CFD-p

Code	Description	L	B	d2	l	f _{±0.25}	f1 ±0.25	H	h1	b1	b2	b3	d	d2	C [Nm]	p#	⚖️
422721	CFD.30 p-M3x13	30.5	26.5	M3	13	15	15	12.5	9.5	22.5	15	7	2.5	M3	1	13	
422821	CFD.40 p-M4x18	40.5	34	M4	18	20	20.2	16.5	12.5	29.5	20	9.5	4	M4	1.5	26	
422921	CFD.48 p-M5x17	48.5	40.5	M5	17	24	23	20	15	35	24	11.5	5	M5	3	47	
423021	CFD.66 p-M6x16	66	56	M6	16	33	31.8	27.5	21	48.5	33	15	6	M6	5	95	

CFD-p-B

Code	Description	L	B	d1	h	d2	l	f _{±0.25}	f1 ±0.25	H	h1	b1	b2	b3	d	d1	d2	C [Nm]	C [Nm]	⚖️
																		B#	p#	
422731	CFD.30 p-M3x13-B-M3	30.5	26.5	M3	4	M3	13	15	15	12.5	9.5	22.5	15	7	2.5	M3	M3	1	1	10
422831	CFD.40 p-M4x18-B-M4	40.5	34	M4	5.5	M4	18	20	20.2	16.5	12.5	29.5	20	9.5	4	M4	M4	4	1.5	23
422931	CFD.48 p-M5x17-B-M5	48.5	40.5	M5	6.5	M5	17	24	23	20	15	35	24	11.5	5	M5	M5	5	3	41
423031	CFD.66 p-M6x16-B-M6	66	56	M6	9	M6	16	33	31.8	27.5	21	48.5	33	15	6	M6	M6	5	5	90

Suggested tightening torque for assembly screws.



- 1
- 2
- 3
- 4
- 5
- 6
- 7
- 8
- 9
- 10
- 11
- 12
- 13
- 14
- 15
- 16
- 17
- 18
- 19

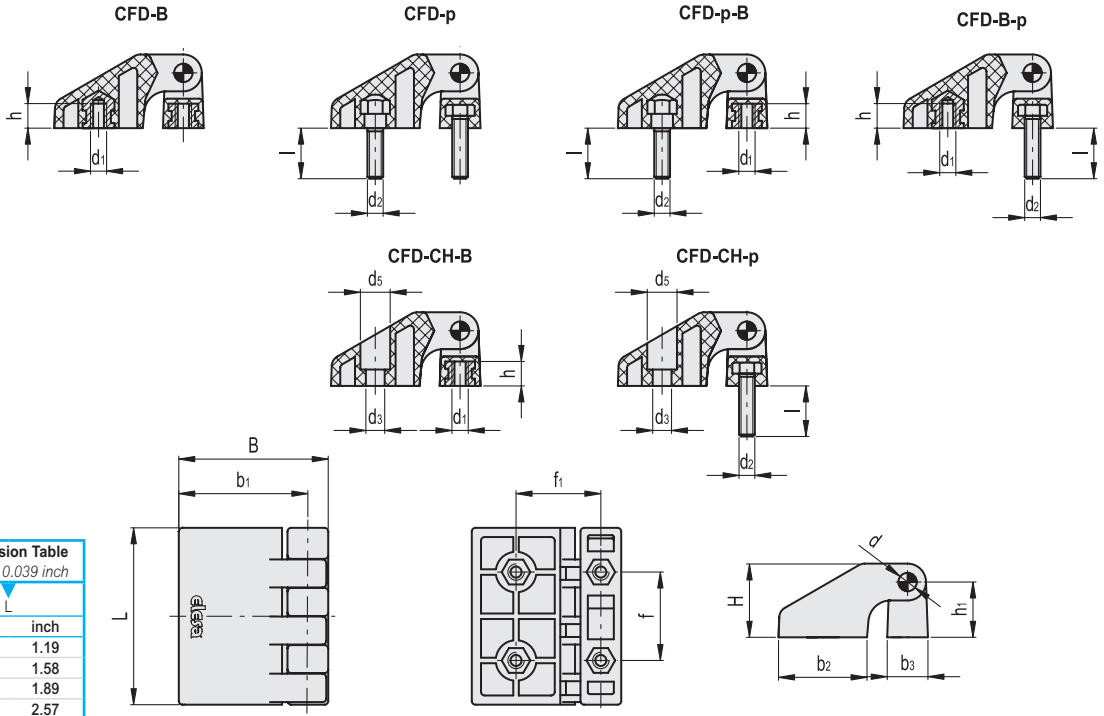

Conversion Table	
1 mm = 0.039 inch	
mm	inch
30.5	1.19
40.5	1.58
48.5	1.89
66	2.57

METRIC

CFD-B-p

Code	Description	L	B	d1	h	d2	l	f ± 0.25	f1 ± 0.25	H	h1	b1	b2	b3	d	d1	d2	C [Nm] B#	C [Nm] p#	Δ
422741	CFD.30 B-M3-p-M3x13	30.5	26.5	M3	4	M3	13	15	15	12.5	9.5	22.5	15	7	2.5	M3	M3	1	1	11
422841	CFD.40 B-M4-p-M4x18	40.5	34	M4	5.5	M4	18	20	20.2	16.5	12.5	29.5	20	9.5	4	M4	M4	4	1.5	24
422941	CFD.48 B-M5-p-M5x17	48.5	40.5	M5	6.5	M5	17	24	23	20	15	35	24	11.5	5	M5	M5	5	3	38
423041	CFD.66 B-M6-p-M6x16	66	56	M6	9	M6	16	33	31.8	27.5	21	48.5	33	15	6	M6	M6	5	5	82

CFD-CH-B

Code	Description	L	B	d1	h	f ± 0.25	f1 ± 0.25	H	h1	b1	b2	b3	d	d1	d3	d5	C [Nm] B#	C [Nm] CH#	Δ
422751	CFD.30 CH-3-B-M3	30.5	26.5	M3	4	15	15	12.5	9.5	22.5	15	7	2.5	M3	3.5	6	1	0.5	7
422851	CFD.40 CH-4-B-M4	40.5	34	M4	5.5	20	20.2	16.5	12.5	29.5	20	9.5	4	M4	4.5	7.5	4	1	20
422951	CFD.48 CH-5-B-M5	48.5	40.5	M5	6.5	24	23	20	15	35	24	11.5	5	M5	5.5	9	-	2	31
423051	CFD.66 CH-6-B-M6	66	56	M6	9	33	31.8	27.5	21	48.5	33	15	6	M6	6.5	10.5	5	5	74

CFD-CH-p

Code	Description	L	B	d2	l	f ± 0.25	f1 ± 0.25	H	h1	b1	b2	b3	d	d2	d3	d5	C [Nm] p#	C [Nm] CH#	Δ
422761	CFD.30 CH-3-p-M3x13	30.5	26.5	M3	13	15	15	12.5	9.5	22.5	15	7	2.5	M3	3.5	6	1	0.5	8
422861	CFD.40 CH-4-p-M4x18	40.5	34	M4	18	20	20.2	16.5	12.5	29.5	20	9.5	4	M4	4.5	7.5	1.5	1	21
422961	CFD.48 CH-5-p-M5x17	48.5	40.5	M5	17	24	23	20	15	35	24	11.5	5	M5	5.5	9	3	2	31
423061	CFD.66 CH-6-p-M6x16	66	56	M6	16	33	31.8	27.5	21	48.5	33	15	6	M6	6.5	10.5	5	5	71