

- 1
- 2
- 3
- 4
- 5
- 6
- 7
- 8
- 9
- 10
- 11
- 12
- 13
- 14
- 15
- 16
- 17
- 18
- 19

MATERIAL

Fine turned AISI 304 stainless steel.

UPPER RING OF THE PROTECTIVE SLEEVE (GBS)

NBR synthetic rubber hardness 70 +/-5 Shore A, blue colour, in compliance with FDA.

LOWER RING OF THE PROTECTIVE SLEEVE (GBI)

Polyurethane elastomer TPU hardness 95 +/-5 Shore A, blue colour, in compliance with FDA.

STEM RING (GST)

H-NBR synthetic rubber hardness 85 +/-5 Shore A, blue colour, in compliance with FDA.

BASE RING (GBA)

Silicone hardness 85 +/-5 Shore A, blue colour, in compliance with FDA.

FEATURES AND APPLICATIONS

LM-HD-SST levelling elements are intended for use in environments where high hygiene is required.

The surface beneath the support base is protected by rings that prevent dirt from entering when the levelling element is pressed by the weight of the equipment.

The adjustable protective sleeve, which covers the threaded part of the stem, is provided both at the top and bottom with a protective ring, as well as the base of the threaded stem. These rings prevent access to dirt inside the coupling between the threaded stud and the adjustable protective sleeve.

The finish quality of stainless steel parts prevents dirt adhering and facilitates cleaning.

The static load values in the table below are the result of laboratory tests in which the load has been applied perpendicularly to the base. Such values have to be considered as purely indicative and must be verified under the specific conditions of use.

Under common working conditions, side or angular loading increases the stress on the levelling element and reduces its carrying capacity.

It's the user's responsibility to determine, case by case, whether the product is suitable for the intended use.

See Hygienic Design technical data.

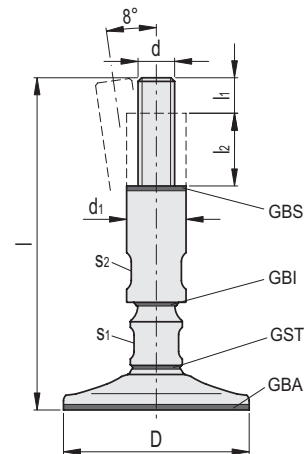

Conversion Table

1 mm = 0.039 inch

D	
mm	inch
60	2.34
80	3.12
100	3.90
120	4.68



Code	Description	D	d	d1	l	l1	l2	s1	s2	Static load [N]	⚖️
406081	LM-HD-60-SST-M12x175	60	M12	175	14	35	25	17	19	16000	660
406083	LM-HD-60-SST-M12x225	60	M12	225	14	35	17	19	19	16000	940
406086	LM-HD-60-SST-M16x175	60	M16	28	175	19	35	18	22	30000	955
406088	LM-HD-60-SST-M16x225	60	M16	28	225	19	35	18	22	30000	1036
406097	LM-HD-80-SST-M12x175	80	M12	25	175	14	35	17	19	16000	906
406099	LM-HD-80-SST-M12x225	80	M12	25	225	14	35	17	19	16000	950
406101	LM-HD-80-SST-M16x175	80	M16	28	175	19	35	18	22	30000	904
406106	LM-HD-80-SST-M16x225	80	M16	28	225	19	35	18	22	30000	983
406111	LM-HD-80-SST-M20x185	80	M20	32	185	24	35	24	27	47000	1115
406116	LM-HD-80-SST-M20x235	80	M20	32	235	24	35	24	27	47000	1243
406121	LM-HD-80-SST-M24x185	80	M24	36	185	29	35	24	30	67000	1284
406126	LM-HD-80-SST-M24x235	80	M24	36	235	29	35	24	30	67000	1458
406131	LM-HD-100-SST-M16x175	100	M16	28	175	19	35	18	22	30000	1171
406136	LM-HD-100-SST-M16x225	100	M16	28	225	19	35	18	22	30000	1252
406141	LM-HD-100-SST-M20x185	100	M20	32	185	24	35	24	27	47000	1385
406146	LM-HD-100-SST-M20x235	100	M20	32	235	24	35	24	27	47000	1513
406151	LM-HD-100-SST-M24x185	100	M24	36	185	29	35	24	30	67000	1546
406156	LM-HD-100-SST-M24x235	100	M24	36	235	29	35	24	30	67000	1726
406161	LM-HD-120-SST-M16x175	120	M16	28	175	19	35	18	22	30000	1465
406166	LM-HD-120-SST-M16x225	120	M16	28	225	19	35	18	22	30000	1549
406171	LM-HD-120-SST-M20x185	120	M20	32	185	24	35	24	27	47000	1691
406176	LM-HD-120-SST-M20x235	120	M20	32	235	24	35	24	27	47000	1818
406181	LM-HD-120-SST-M24x185	120	M24	36	185	29	35	24	30	67000	1853
406186	LM-HD-120-SST-M24x235	120	M24	36	235	29	35	24	30	67000	2031

Levelling feet and supports