

# DIN-Rail EMC/RFI Filter with Minimum Leakage Current



- Compact state-of-the-art filter concept
- Light weight plastic enclosure design
- Minimized filter leakage current
- Hinged safety covers
- Revolutionary embedded filter terminals
- Chassis or DIN-rail mounting option
- Selectable performance level
- Environmental friendly design without potting compound



### Performance indicators

Attenuation performance



Rated current [A]

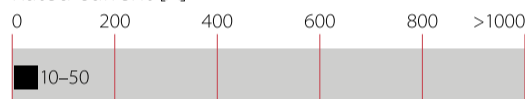

## Technical Specifications

<b>Maximum continuous operating voltage</b>	3x520/300 VAC
<b>Nominal operating voltage</b>	480 VAC
<b>Rated currents</b>	10 to 50 A @ 50°C
<b>Overload capability</b>	4x rated current at switch on, 1.5x rated current for 1 minute, once per hour
<b>Operating frequency</b>	DC to 60 Hz
<b>High potential test voltage</b>	P -> E 2000 VAC for 2 sec (HL types) P -> E 3000 VDC for 2 sec (HP types) P -> P 2250 VDC for 2 sec
<b>Temperature range (operation and storage)</b>	-25°C to +100°C (25/100/21)
<b>Protection category</b>	IP 00 (protection according to VBG 4)
<b>Flammability corresponding to</b>	UL 94 V-0
<b>Design corresponding to</b>	UL 1283, CSA 22.2 No. 8 1986, IEC/EN 60939
<b>MTBF (Mil-HB-217F)</b>	>200,000 h @ 50°C/480 V

### Approvals & Compliances



Design protected by European patent (EP 1727280);  
40A Version does not offer any approvals

### Features and Benefits

- Two different mounting versions: FN 3025 for chassis mounting and FN3026 for DIN rail mounting
- Two different performance levels (L types, P types)
- A plastic housing and a metal ground plate are cleverly combined to get the lowest possible product weight without compromising EMC behavior
- The embedded jump-terminal system from Schaffner guarantees user-friendly handling as well as fast and reliable electrical connection
- Captive hinged protective covers contribute to overall safety by offering protection against unintended contact with live conductors. They are included in the standard delivery package without causing extra cost
- Very low leakage current values make these filter ranges ideally suitable for use in Japanese electricity networks as well as in applications which set value on safety and reliability

### Typical Applications

- Applications with the requirement for extremely compact filter solutions
- Applications with tough leakage current requirements or sensitive earth leakage detectors
- Applications with insufficient internal filtering or moderate interference levels
- Automation equipment
- Motor drives and servo drives with short motor cables
- Applications including stepping motors
- Semiconductor manufacturing equipment
- Three-phase power supplies
- Medical equipment (not patient-coupled)

### Typical electrical schematic

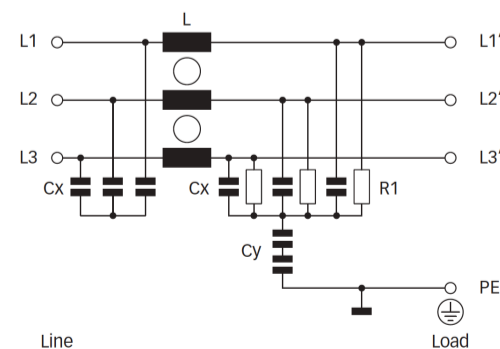

### Filter Selection Table

Filter	Rated current @ 50°C (40°C)	Typical drive power rating*	Leakage current** @ 520 VAC/50 Hz	Power loss @ 25°C/50 Hz	Input/Output connections 	Weight [kg]
	[A]	[kW]	[mA]	[W]		
<b>FN 3025 HL-10-71</b>	10 (10.7)	5.5	0.1	4.8	-71	0.52
<b>FN 3025 HL-20-71</b>	20 (21.4)	11	0.1	6.2	-71	0.52
<b>FN 3025 HL-30-71</b>	30 (32.1)	18.5	0.1	7.0	-71	0.54
<b>FN 3025 HL-40-71</b>	40 (43.8)	25	0.1	8.5	-71	0.63
<b>FN 3025 HL-50-72</b>	50 (53.5)	30	0.1	10.5	-72	0.93
<b>FN 3025 HP-10-71</b>	10 (10.7)	5.5	0.4	4.8	-71	0.52
<b>FN 3025 HP-20-71</b>	20 (21.4)	11	0.4	6.2	-71	0.52
<b>FN 3025 HP-30-71</b>	30 (32.1)	18.5	0.4	7.0	-71	0.54
<b>FN 3025 HP-40-71</b>	40 (43.8)	25	0.4	8.5	-71	0.63
<b>FN 3025 HP-50-72</b>	50 (53.5)	30	0.4	10.5	-72	0.93
<b>FN 3026 HL-10-71</b>	10 (10.7)	5.5	0.1	4.8	-71	0.56
<b>FN 3026 HL-20-71</b>	20 (21.4)	11	0.1	6.2	-71	0.56
<b>FN 3026 HL-30-71</b>	30 (32.1)	18.5	0.1	7.0	-71	0.58
<b>FN 3026 HL-40-71</b>	40 (43.8)	25	0.1	8.5	-71	0.74
<b>FN 3026 HL-50-72</b>	50 (53.5)	30	0.1	10.5	-72	0.98
<b>FN 3026 HP-10-71</b>	10 (10.7)	5.5	0.4	4.8	-71	0.56
<b>FN 3026 HP-20-71</b>	20 (21.4)	11	0.4	6.2	-71	0.56
<b>FN 3026 HP-30-71</b>	30 (32.1)	18.5	0.4	7.0	-71	0.58
<b>FN 3026 HP-40-71</b>	40 (43.8)	25	0.4	8.5	-71	0.74
<b>FN 3026 HP-50-72</b>	50 (53.5)	30	0.4	10.5	-72	0.98

\* Calculated at rated current, 480 VAC and cos phi=0.8. The exact value depends upon the efficiency of the drive, the motor and the entire application.

\*\* Standardized calculated leakage current acc. IEC60939 under normal operating conditions.

### Typical Filter Attenuation

Per CISPR 17; A=50 Ω/50 Ω sym; B=50 Ω/50 Ω asym; C=0.1 Ω/100 Ω sym; D=100 Ω/0.1 Ω sym

10 and 20 A HL types

10 and 20 A HP types

30 to 50 A HL types

30 to 50 A HP types

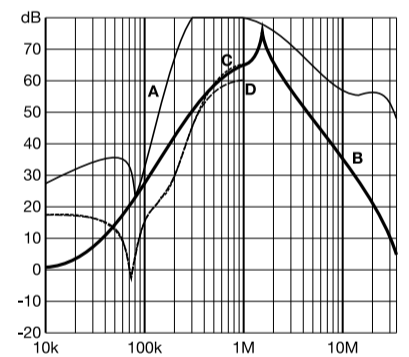
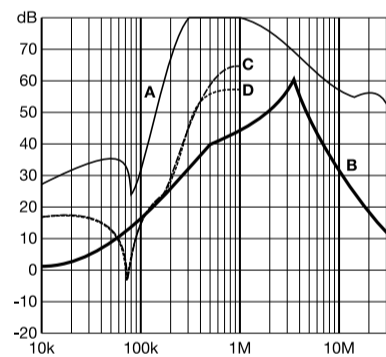
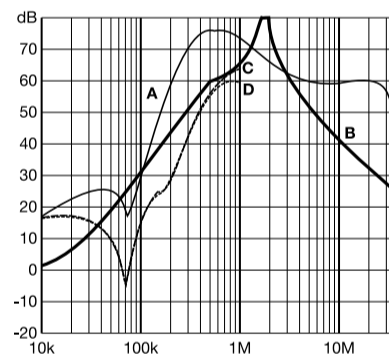
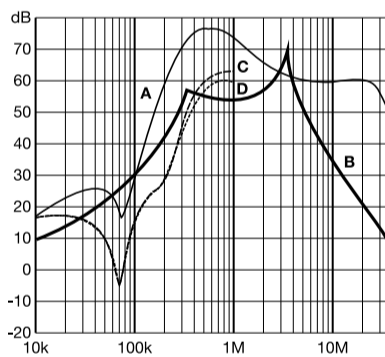

## Installation

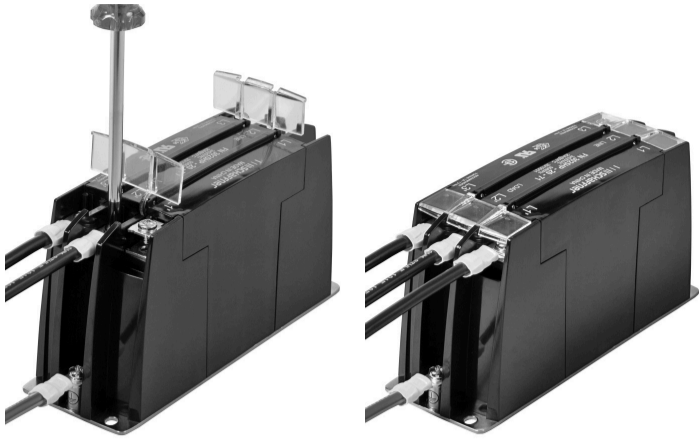

FN 3025/FN 3026 are delivered with closed plastic covers and unfastened terminals. To install the filter please proceed as follows:

- Mount the filter on a metal surface with four screws or snap it onto a TS 35 DIN- rail.
- First connect the green/yellow wire to the earth stud of the filter.
- Gently lift the two hinged plastic covers.
- Connect phase wires with cable lugs by pushing down and tightening the screws.
- Please note the torque recommendation on top of the filter.
- Push the covers back into their locked position to finish the filter installation.

## Mechanical Data

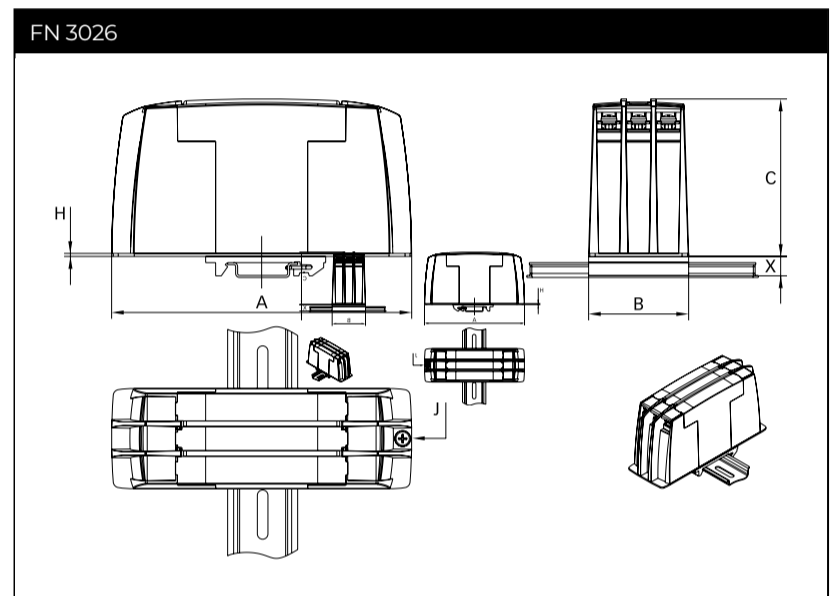
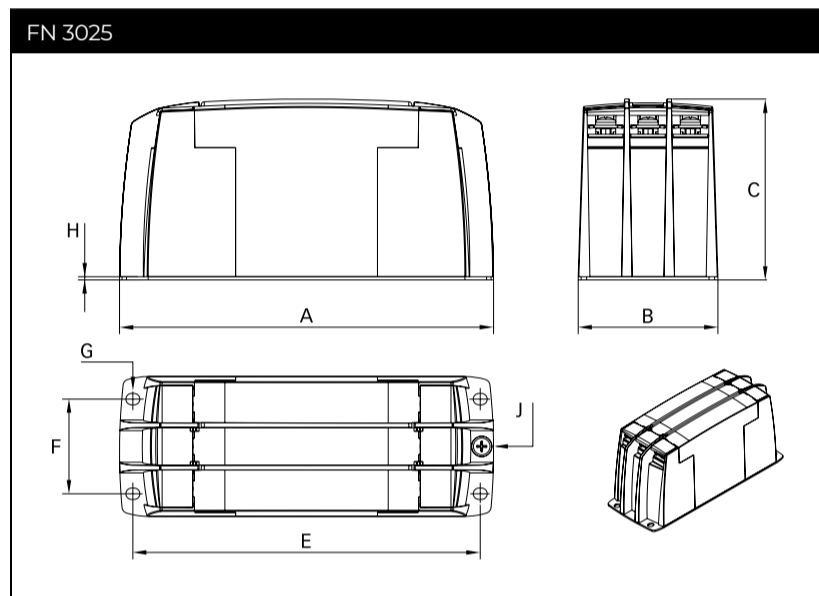

## Dimensions





50

	FN 3025					FN 3026				
	10 A	20 A	30 A	40 A	50 A	10 A	20 A	30 A	40 A	50 A
<b>A</b>	150	150	150	150	177	150	150	150	150	177
<b>B</b>	50	50	50	50	65	50	50	50	50	65
<b>C</b>	78	78	78	78	84	78	78	78	78	84
<b>E</b>	140	140	140	140	162					
<b>F</b>	32	32	32	32	44					
<b>G</b>	4.3 x 5.5	4.3 x 5.5	4.3 x 5.5	4.3 x 5.5	5.3 x 6.5					
<b>H</b>	1.5	1.5	1.5	1.5	1.5	1.5	1.5	1.5	1.5	1.5
<b>J</b>	M4	M4	M4	M4	M5	M4	M4	M4	M4	M5
<b>X</b>						9.7	9.7	9.7	9.7	9.7

All dimensions in mm; 1 inch = 25.4 mm

Tolerances according: ISO 2768-m/EN 22768-m

## Filter Input/Output Connector Cross Sections

	-71 (10 A)	-71 (20 A)	-71 (30 A and 40 A)	-72 (50 A)
				
<b>Flex wire</b>	1.3-2.5 mm <sup>2</sup>	4-6 mm <sup>2</sup>	8-10 mm <sup>2</sup>	16-20 mm <sup>2</sup>
<b>AWG type wire</b>	AWG 16-AWG 13	AWG 12-AWG 10	AWG 8-AWG 7	AWG 5-AWG 4
<b>Ring/fork lug (W/d)*</b>	max. 11 mm (9.5 mm)/ min. Ø4.3 mm**	max. 11 mm (9.5 mm)/ min. Ø4.3 mm**	max. 11 mm (9.5 mm)/ min. Ø4.3 mm**	max. 16.5 mm (15 mm)/ min. Ø5.3 mm**
<b>Recommended torque</b>	1.0-1.2 Nm	1.0-1.2 Nm	1.0-1.2 Nm	1.9-2.2 Nm

\* Schaffner recommends the use of insulated and UL-recognized ring lugs or fork lugs of the appropriate size.

\*\* Specification in ( ) relates to earth connector.

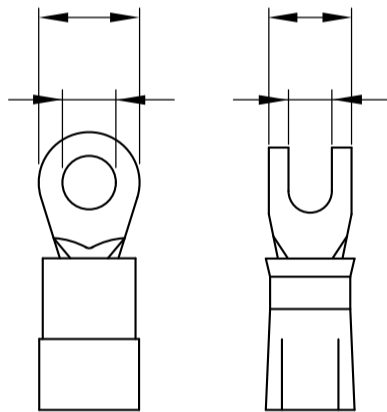
Please visit [www.schaffner.com](http://www.schaffner.com) to find more details on filter connectors.

## Headquarters, Global Innovation and Development

### Switzerland

#### Schaffner Group

Industrie Nord  
Nordstrasse 5  
4542  
Luterbach  
+41 32 681 66 26  
[info@schaffner.com](mailto:info@schaffner.com)

## Sales and Application Centers

### Finland

#### Schaffner Oy

Lohjanharjuntie 1109  
08500  
Lohja  
+ 358 50 468 72 84  
[finlandsales@schaffner.com](mailto:finlandsales@schaffner.com)

### France

#### Schaffner EMC S.A.S.

16-20 Rue Louis Rameau  
95875  
Bezons  
+33 1 34 34 30 60  
[francesales@schaffner.com](mailto:francesales@schaffner.com)

### Germany

#### Schaffner Deutschland GmbH

Ohiostr. 8  
76149  
Karlsruhe  
+49 721 56910  
[germanysales@schaffner.com](mailto:germanysales@schaffner.com)

### Italy

#### Schaffner EMC S.r.l.

Via Ticino, 30  
20900  
Monza (MB)  
+39 335 120 44 32  
[italysales@schaffner.com](mailto:italysales@schaffner.com)

### Japan

#### Schaffner EMC K.K.

ISM Sangenjaya 7F  
1-32-12 Kamiyama Setagaya-ku  
154-0011  
Tokyo  
+81 3 5712 3650  
[japansales@schaffner.com](mailto:japansales@schaffner.com)

### Singapore

#### Schaffner EMC Pte Ltd.

Blk 3015A Ubi Road 1 #05-09 Kampong Ubi  
Industrial Estate  
408705  
Singapore  
+65 63773283  
[singaporesales@schaffner.com](mailto:singaporesales@schaffner.com)

### Sweden

#### Schaffner EMC AB

Östermalmströgr 1  
114 42  
Stockholm  
+46 8 5050 2425  
[swedensales@schaffner.com](mailto:swedensales@schaffner.com)

### Switzerland

#### Schaffner EMV AG

Industrie Nord  
Nordstrasse 5  
4542  
Luterbach  
+41 32 681 66 26  
[switzerlandsales@schaffner.com](mailto:switzerlandsales@schaffner.com)

### India

#### Schaffner India Pvt. Ltd

Regus World Trade Centre  
WTC 22nd Floor Unit No 2238 Brigade  
Gateway Campus 26/1 Dr. Rajkumar Road  
Malleshwaram (W)  
560055  
Bangalore  
+91 8067935355  
[indiasales@schaffner.com](mailto:indiasales@schaffner.com)

### United Kingdom

#### Schaffner Ltd.

Suite 1 Oakmede Place  
Terrace Road  
RG42 4JF  
Binfield  
+44 118 9770070  
[schaffner.uksales@te.com](mailto:schaffner.uksales@te.com)

### United States

#### Schaffner EMC Inc.

52 Mayfield Avenue  
Edison, New Jersey  
+1 732 225 9533  
[usasales@schaffner.com](mailto:usasales@schaffner.com)

To find your local partner within Schaffner's global network [schaffner.com](http://schaffner.com)

© 2025 Schaffner Group

The content of this document has been carefully checked and understood. However, neither Schaffner nor its subsidiaries assume any liability whatsoever for any errors or inaccuracies of this document and the consequences thereof. Published specifications are subject to change without notice. Product suitability for any area of application must ultimately be determined by the customer. In all cases, products must never be operated outside their published specifications. Schaffner does not guarantee the availability of all published products. This disclaimer shall be governed by substantive Swiss law and resulting disputes shall be settled by the courts at the place of business of Schaffner Holding AG. Latest publications and a complete disclaimer can be downloaded from the Schaffner website. All trademarks recognized.