

## Evaluates: MAX30102

## MAX30102 Evaluation Kit

### General Description

The MAX30102 evaluation kit (EV kit) provides a proven design to evaluate the MAX30102 integrated pulse-oximetry and heart-rate monitor integrated circuit (IC). The EV kit consist of two boards. USBOSMB is the mother board and MAX30102DBEVKIT is the daughter board that includes the MAX30102 and an accelerometer. The EV kit is powered using the USB supply to generate +1.8V for the sensor and +4.5V for the internal LEDs of the MAX30102, and +3.3V for the accelerometer.

The EV kit comes with a MAX30102EFD+ installed in a 14-pin OESIP package.

### Features and Benefits

- Real-Time Monitoring
- Flexible PCB Design
- USB-Powered
- On-Board Accelerometer
- Proven PCB Layout
- Fully Assembled and Tested
- Windows® 7-, and Windows 8/8.1-Compatible Software

[Ordering Information](#) appears at end of data sheet.

*Windows is a registered trademark and registered service mark of Microsoft Corporation.*

### Quick Start

#### Required Equipment

- MAX30102 accelerometer EV kit (MAX30102DBEVKIT#, USBOSMB#, 10-pin FFC cable, and micro USB cable included)
- Windows PC

#### Note:

- 1) Text in **bold** refers to items directly from the EV kit software. Text in **bold and underlined** refers to items from the Windows operating system.
- 2) The GUI setup files can be obtained by the [Procedure](#) section.
- 3) EVKIT design files are attached at the end of this document.

#### Procedure

The EV kit is fully assembled and tested. Follow the steps below to verify board operation:

- 1) Visit [www.analog.com/evkit-software](http://www.analog.com/evkit-software) to download the most recent version of the EV kit software, MAX30102EVKitSetupVx.x.ZIP. Save the EV kit software to a temporary folder and uncompress the ZIP file.
- 2) Open up MAX30102EVKitSetupVx.x.exe and follow the instructions from the pop-up windows.
- 3) Insert one end of the ribbon cable to the J3 connector of the USBOSMB and the other end of the ribbon cable to the J1 connector of the MAX30102DBEVKIT. Make sure that both connectors and blue ends of the ribbon cable is facing the user.
- 4) Connect the USB cable from the PC to the EV kit board. Windows will automatically install all drivers.
- 5) Open the MAX30102EVKit.exe and verify that the EV kit is connected by observing the status bar at the lower left corner of the GUI. See [Figure 1](#).
- 6) Press the **Start Monitor** button.
- 7) Place your finger in front of the MAX30102 (U4) of the EV kit and observe the **Measurement** graphs. See [Figure 2](#). Example algorithm 1 and 2 are shown in separate windows ([Figure 3](#) and [Figure 4](#)).

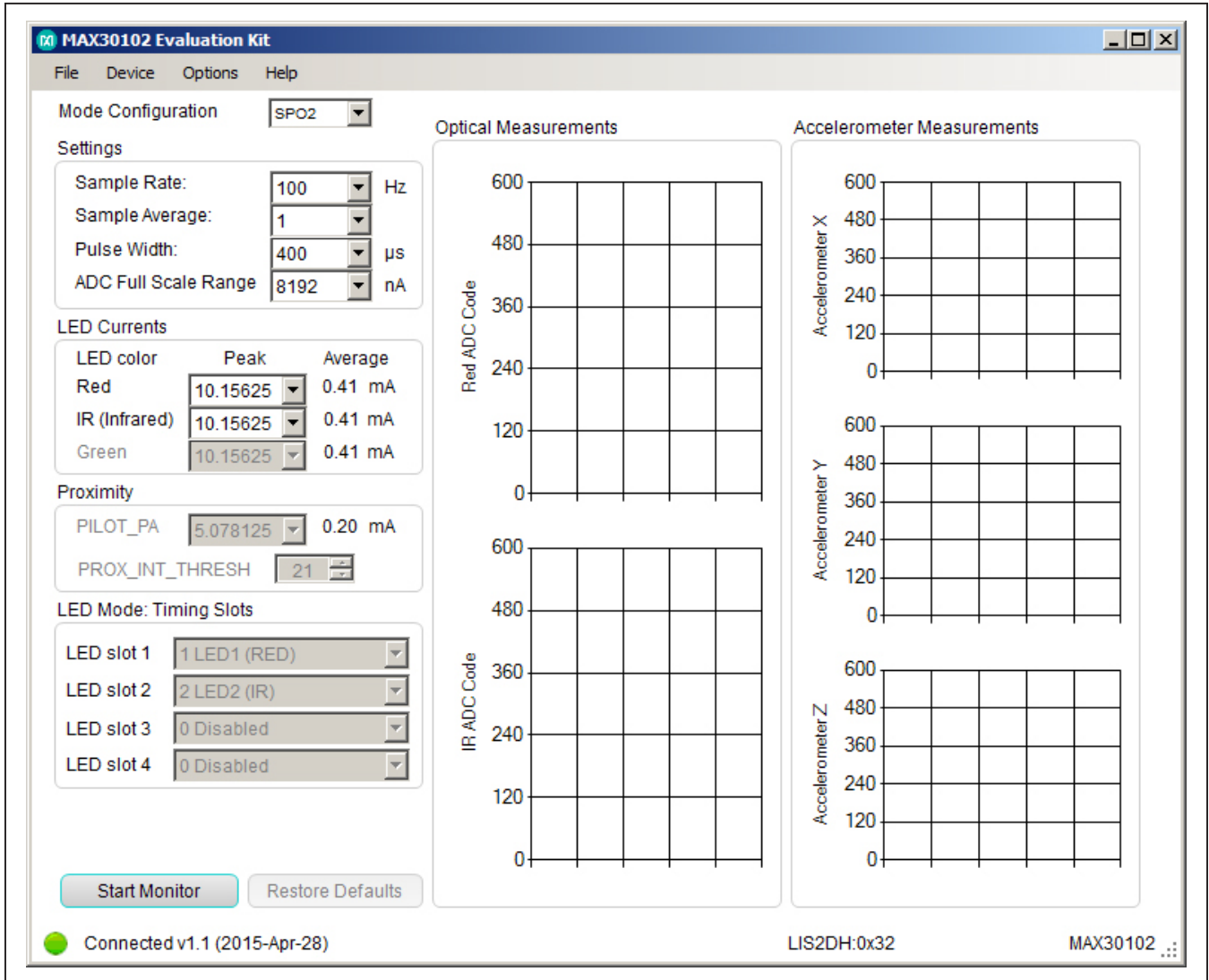

Figure 1. MAX30102 EV Kit Main Window

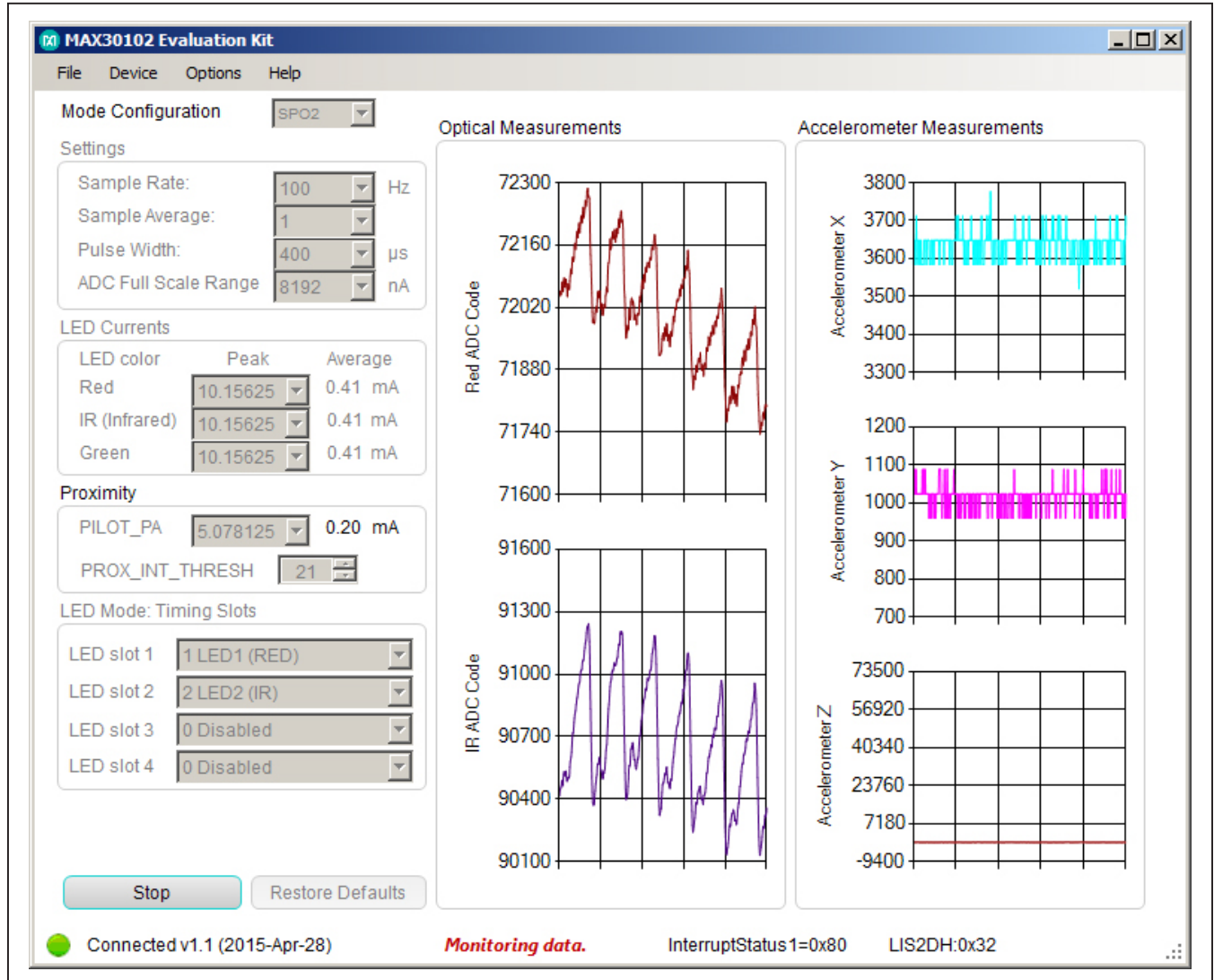

Figure 2. MAX30102 EV Kit Main Window (Sampling Data)

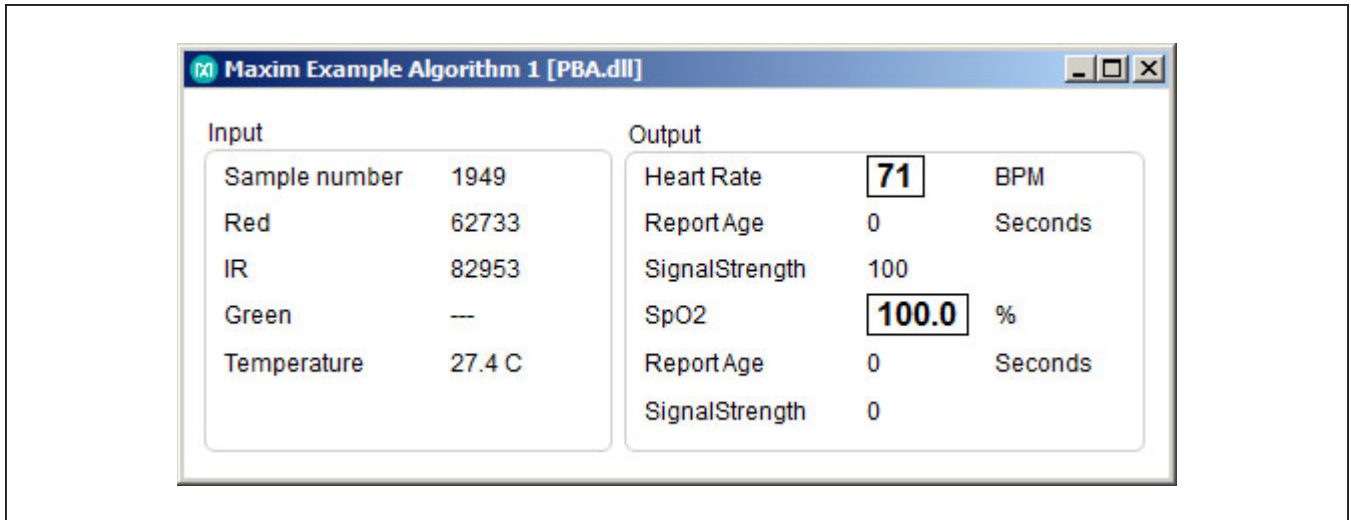

Figure 3. Maxim Example Algorithm 1 Window

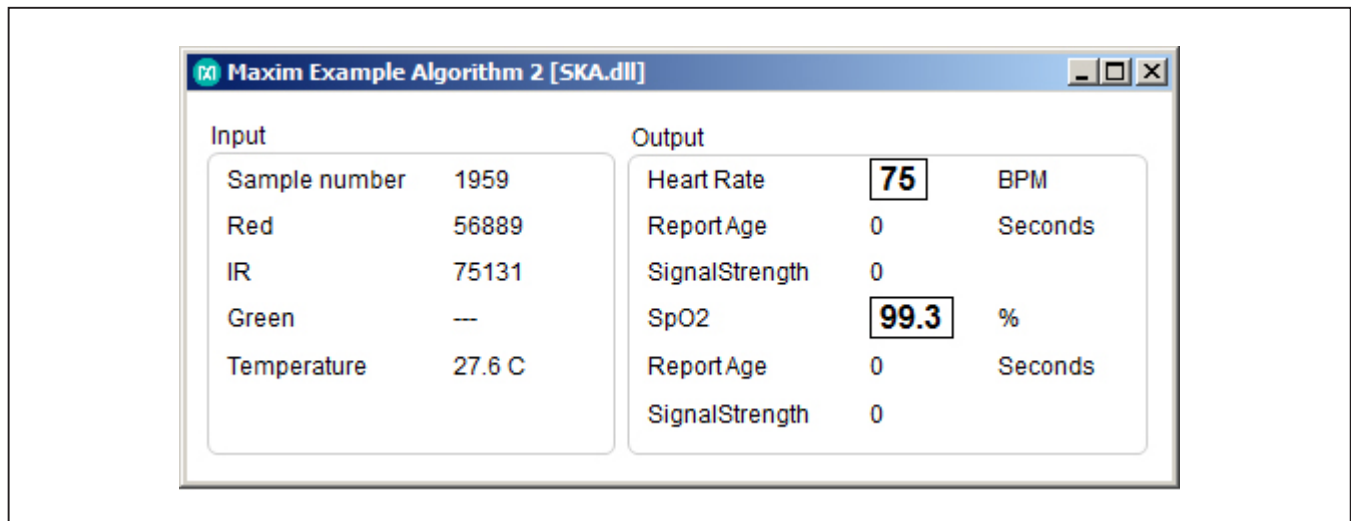

Figure 4. Maxim Example Algorithm 2 Window

### Detailed Description of Software

The main window of the MAX30102 EV kit software displays the mode configuration, settings, LED currents, proximity, timing slots of the LED mode, ADC code measurements, of both the MAX30102 and the accelerometer and example algorithms.

### Mode Configuration

The **Mode Configuration** drop-down list allows for three options: HR, SPO2, and LED. When HR is selected, only

red ADC codes are plotted. When SPO2 is selected, only the Red and IR channels will be active when the GUI is operational. While the Green channel is shown, it will always reads zero. The MAX30102 device does not incorporate an embedded Green LED.

it will always reads zero. The MAX30102 device does not incorporate an embedded Green LED. . Within LED mode, the **Led Mode Timing Slots** groupbox selections allow the user to enable the desired LEDs at each LED slot.

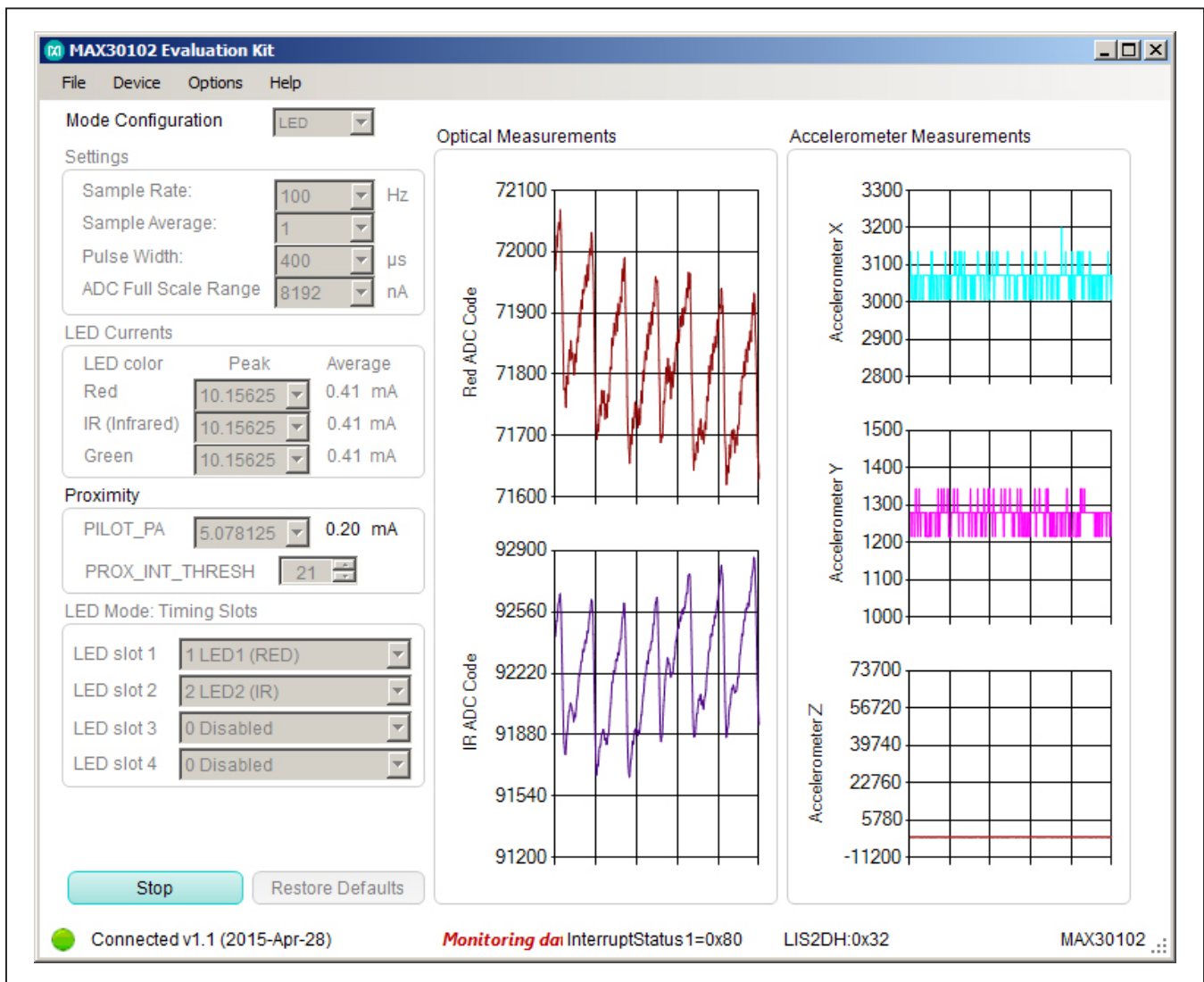

Figure 5. MAX30102 EV Kit Main Window (LED Mode with Green LED)

**Settings**

The **Settings** groupbox consist of controls to the sample rate and average, pulse width, and ADC full-scale range.

The **Sample Rate** drop-down list is adjustable from 50Hz to 400Hz.

The **Sample Average** drop-down list is adjustable from 1 to 32.

The **Pulse Width** dropdown list is adjustable from 50µs to 400µs.

The **ADC Full Scale Range** dropdown list is adjustable from 2048nA to 16384nA.

**LED Currents**

Within the **LED Currents** groupbox, the peak currents are adjustable from **0** to **50** mA for each LED. The average current based on the **Pulse Width** and **Sample Rate** is recalculated with each change in peak current.

**Proximity**

Under Proximity, **PILOT\_PA** is adjustable from **0** to **50** mA.

**Accelerometer**

The accelerometer provides three degrees of freedom (3DOF). Moving the MAX30102DBEVKIT board will trigger changes in ADC data of the X, Y, and/or Z graphs.

**Algorithms**

[Figure 3](#) and [Figure 4](#) are example algorithms to calculate heart rate and SpO<sub>2</sub>. They are calculated using the raw ADC data from the LEDs.

The two algorithms included with the EV kit are PBA and SKA. They are provided to demonstrate the capability of the product and are not intended for mass production. Here are some significant differences between the two.

PBA looks for zero crossing using slow threshold. The algorithm completes its cycle each sampling point. SKA waits for 3s and then looks for peak detection.

ALGORITHM	DELAY	MEMORY	DATA SPACE
PBA	None	5772	870
SKA	3s	31160	52723

The algorithm is processed every 1s, but it requires a more complex math operation. The user needs to present 3s FIFO data to algorithm. Heart rate is from average of 3s of data.

Each of these algorithms has its own advantage. For example, PBA requires much less data space and code space compared to SKA.

**Data Logging**

From the menu bar, select **File | Log** and ADC data can be logged to a .csv file with the option of collecting data for a specific time using the **File | Timed Data Collection** selection from **5** to **60 seconds**. Once the desired configuration is set, press the **Start Monitor** button to capture data. The header for each data set includes the settings for sample rate, LED current, pulse width, and the mode. If the file name is not changed, subsequent data collection will append to the existing file and will include a new header.

**Options**

From the menu bar, **Options** allows the user to adjust the plot length and the x-axis, hide unused channels, show/hide the algorithm windows, and access registers from a bit level.

**Detailed Description of Hardware**

The MAX30102 EV kit provides a proven design to evaluate the MAX30102 integrated pulse-oximetry, heart-rate monitor module. The EV kit is powered through the +5V from the USB port to generate the regulated +1.8V to V<sub>DD</sub> supply and +4.5V to the +VLED supply of the MAX30102. Use [Table 1](#) to change the R10 resistor to obtain the desired +VLED supply. The IC U1 of the USBOSMB is the on-board microcontroller that communicates with the MAX30102 through GPIO for the interrupt signal and I<sup>2</sup>C interface.

There is also a 3.3V supply on the EV board and is intended for the on-board MCU.

**Table 1. Resistor Selection for +VLED Supply**

+VLED	R10 (kΩ)
2.5V	14.3
3.3V	23.2
4.0V	31.6
4.5V	36.5*

\*Default



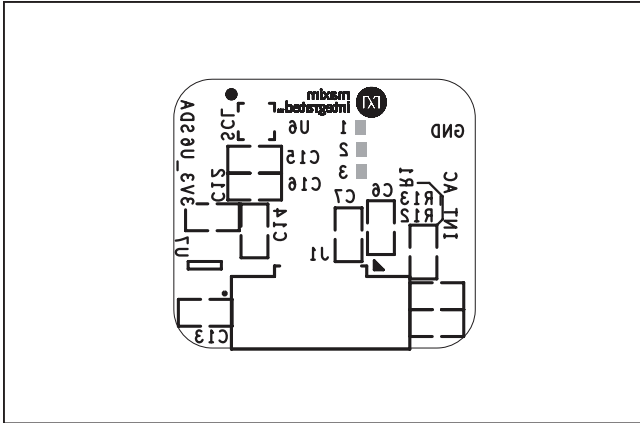

Figure 7. MAX30102 Daughter Board Component Placement Guide—Component Side

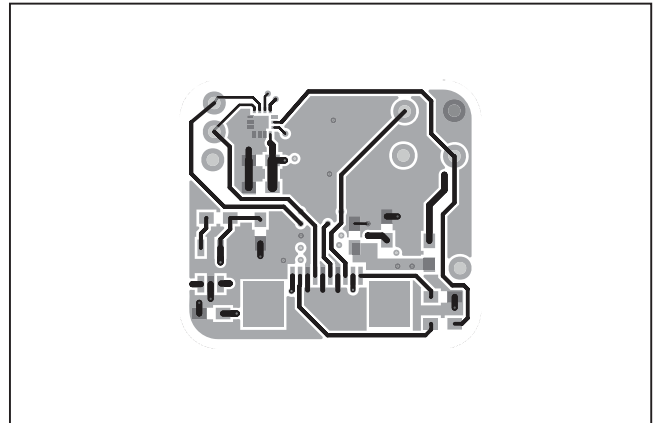

Figure 8. MAX30102 Daughter Board PCB Layout—Layer 2

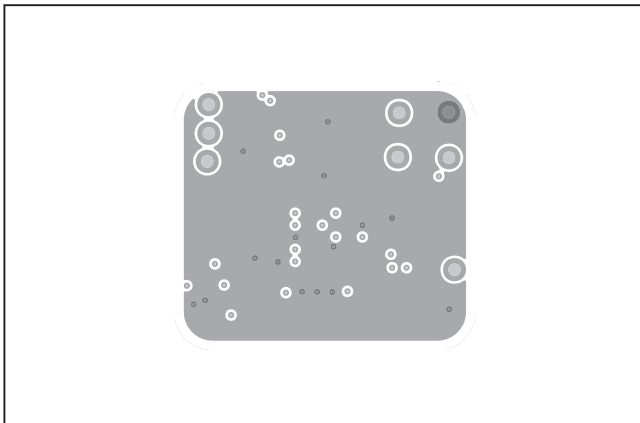

Figure 9. MAX30102 Daughter Board PCB Layout—Layer 3

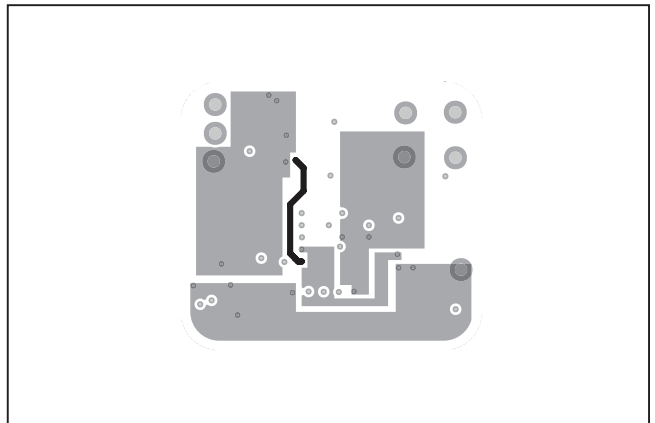

Figure 10. MAX30102 Daughter Board PCB Layout—Component Side

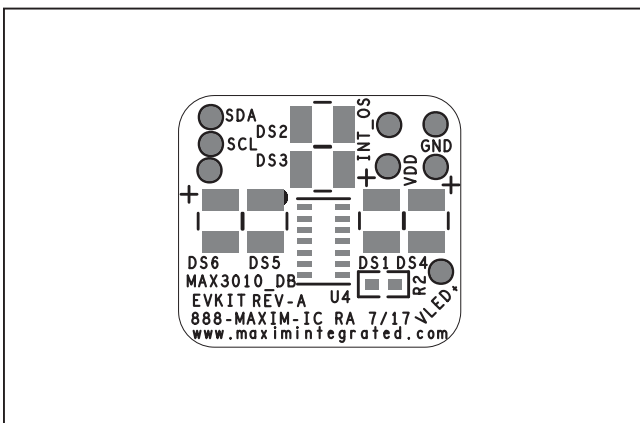

Figure 11. MAX30102 Daughter Board PCB Layout—Solder Side

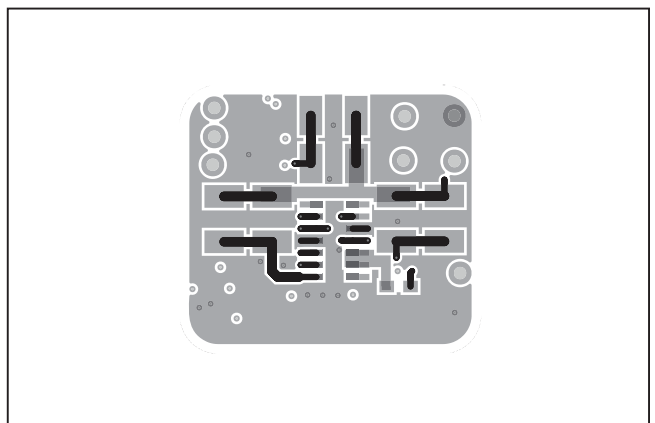

Figure 12. MAX30102 Daughter Board Component Placement Guide—Solder Side

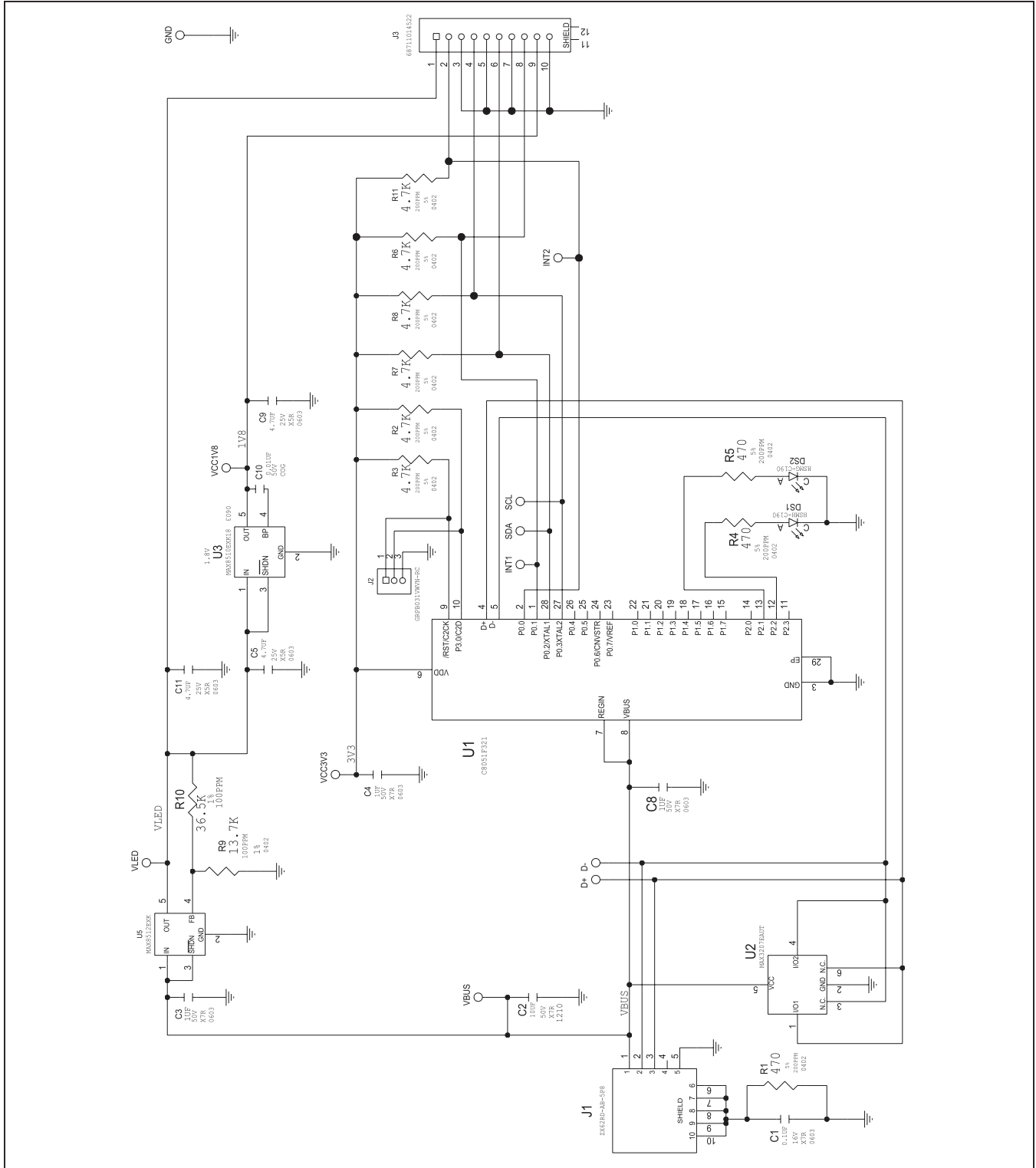

Figure 13. USBOSMB Mother Board Schematic

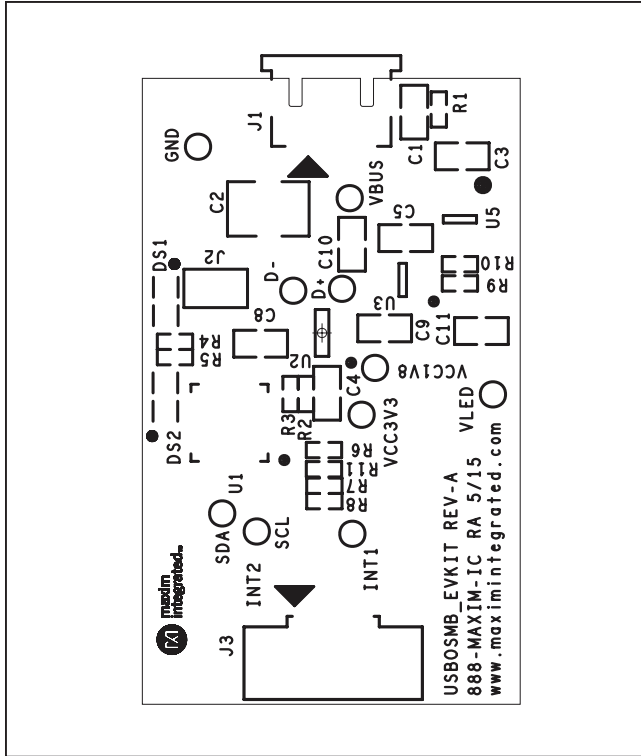

Figure 14. USBOSMB Mother Board Component Placement Guide—Component Side

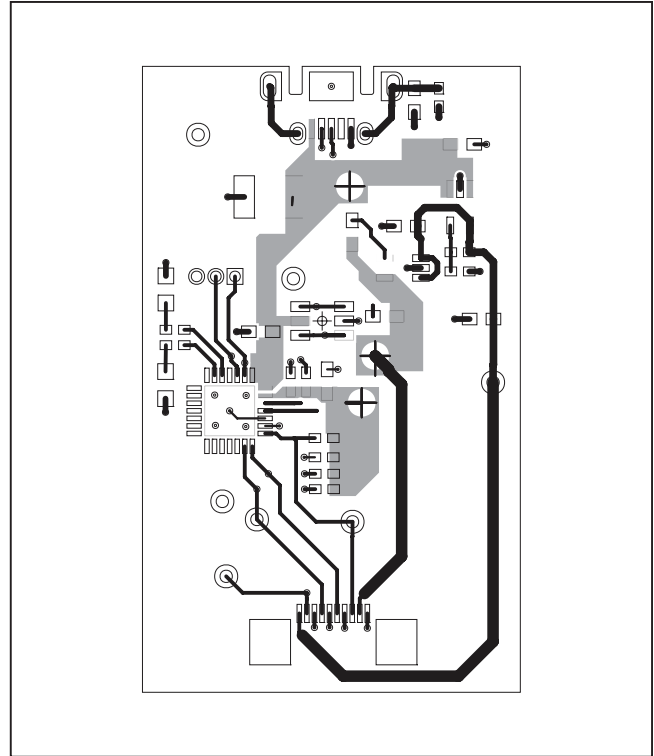

Figure 15. USBOSMB Mother Board PCB Layout—Component Side

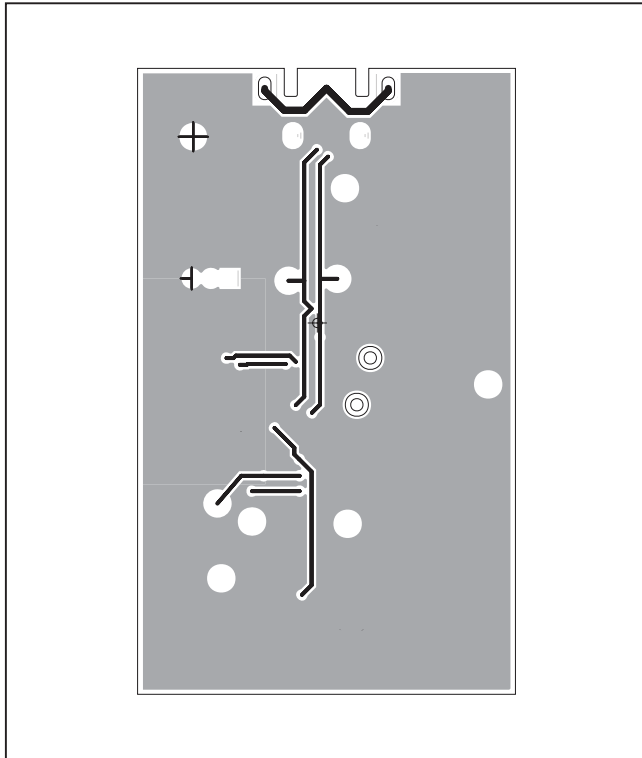

Figure 16. USBOSMB Mother Board PCB Layout—Solder Side

### Component Lists

#### MAX30102 Accelerometer EV Kit

PART	QTY	DESCRIPTION
MAX30102DBEVKIT#	1	MAX30102 Daughter Board
USBOSMB#	1	Serial Interface Mother Board

### Ordering Information

PART	TYPE	LED
MAX30102ACCEVKIT#	EV Kit	IR, Red

#Denotes RoHS compliant.

MAX30102 DB EV BOM

ITEM	QTY	REF DES	MFG PART #	MANUFACTURER	VALUE	DESCRIPTION
1	1	C6	C1608X5R1A106K	TDK	10UF	CAPACITOR; SMT (0603); CERAMIC CHIP; 10UF; 10V; TOL=10%; MODEL=; TG=-55 DEGC TO +85 DEGC; TC=X5R
2	2	C7, C16	C1608X5R1E106M080AC; CL10A106MA8NRNC	TDK/SAMSUNG ELECTRONICS	10UF	CAPACITOR; SMT (0603); CERAMIC CHIP; 10UF; 25V; TOL=20%; TG=-55 DEGC TO +85 DEGC; TC=X5R
3	1	C12	C1608C0G1H103J; CGA3E2C0G1H103J080AD; GRM1885C1H103JA01	TDK; MURATA	0.01UF	CAPACITOR; SMT (0603); CERAMIC CHIP; 0.01UF; 50V; TOL=5%; TG=-55 DEGC to +125 DEGC; TC=C0G
4	1	C13	UMK107AB7105KA	TAIYO YUDEN	1UF	CAPACITOR; SMT (0603); CERAMIC CHIP; 1UF; 50V; TOL=10%; TG=-55 DEGC TO +125 DEGC; TC=X7R
5	1	C14	C1608X5R1E475K080AC	TDK	4.7UF	CAPACITOR; SMT (0603); CERAMIC CHIP; 4.7UF; 25V; TOL=10%; MODEL=C SERIES; TG=-55 DEGC TO +85 DEGC; TC=X5R
6	1	C15	C0603C104K4RACAUTO	KEMET	0.1UF	CAPACITOR; SMT (0603); CERAMIC CHIP; 0.1UF; 16V; TOL=10%; TG=-55 DEGC TO +125 DEGC; TC=X7R AUTO
7	0	DS1, DS4	SMT660N	EPITEX	SMT660N	DIODE; LED; HIGH PERFORMANCE TOP LED; RED; SMT; VF=2V; IF=0.02A
8	0	DS2, DS3	SMT880	EPITEX	SMT880	DIODE; LED; HIGH PERFORMANCE TOP IR LED; INFRARED; SMT; VF=1.45V; IF=0.05A
9	0	DS5, DS6	SMT525	EPITEX	SMT525	DIODE; LED; HIGH PERFORMANCE TOP LED; GREEN; SMT; VF=3.2V; IF=0.02A
10	1	J1	68711014522	WURTH ELECTRONICS INC.	68711014522	CONNECTOR; FEMALE; SMT; 0.5MM ZIF HORIZONTAL BOTTOM CONTACT WR-FPC; RIGHT ANGLE; 10PINS
11	0	R1	RC1608J000CS; CR0603-J/-000ELF; RC0603JR-070RL	SAMSUNG ELECTRONICS/BOURNS/YAGEO PH	0	RESISTOR; 0603; 0 OHM; 5%; JUMPER; 0.10W; THICK FILM
12	3	R2, R12, R13	CRCW06030000ZS; MCR03EZPJ000; ERJ-3GEY0R00	VISHAY DALE/ROHM/PANASONIC	0	RESISTOR; 0603; 0 OHM; 0%; JUMPER; 0.10W; THICK FILM
13	1	U4	MAX30102EFD+	ANALOG DEVICES	MAX30102EFD+	MODULE; SNRS; HIGH-SENSITIVITY PULSE OXIMETER AND HEART-RATE SENSOR FOR WEARABLE; SMT 5.6MM X 3.3MM
14	1	U6	LIS2DH	ST MICROELECTRONICS	LIS2DH	IC; MEMS; MEMS DIGITAL OUTPUT MOTION SENSOR; ULTRA-LOW-POWER HIGH PERFORMANCE 3-AXIS FEMTO ACCELEROMETER; LGA14 2X2
15	1	U7	MAX8510EXK33+	ANALOG DEVICES	MAX8510EXK33+	IC; VREG; ULTRA-LOW-NOISE; HIGH PSRR; LOW-DROPOUT; 0.12A LINEAR REGULATOR; SC70-5
16	1		EPCB	MAX	ANALOG DEVICES	PCB
TOTAL	15					

MAX30102 ACC EV BOM

PACKOUT (These are DO NOT INSTALL parts and will be shipped with PCB)

ITEM	QTY	REF DES	MFG PART #	MANUFACTURER	VALUE	DESCRIPTION
1	1	PACKOUT	88-00713-LRG	N/A	?	BOX;+;LARGE BROWN 15 1/8" X 8 3/4" X 3"
2	1	PACKOUT	87-02162-00	N/A	?	ESD BAG;BAG;STATIC SHIELD ZIP 4inX6in; W/ESD LOGO - PACKOUT
3	3	PACKOUT	85-MAXKIT-PNK	N/A	?	PINK FOAM;FOAM;ANTI-STATIC PE 12inX12inX5MM - PACKOUT
4	3	PACKOUT	EVINSERT	N/A	?	WEB INSTRUCTIONS FOR ANALOG DEVICES DATA SHEET
5	3	PACKOUT	85-84003-006	N/A	?	LABEL(EV KIT BOX) - PACKOUT
6	1	PACKOUT	88-00712-MDM	N/A	?	BOX;+;MEDIUM BROWN 9 3/8" X 7 1/4" X 2 1/2"
7	1	PACKOUT	87-02159-000	N/A	?	ESD BAG;+;BAG; STATIC SHIELD 5"X8"; W/ESD LOGO
8	1	PACKOUT	88-00711-SML	N/A	?	BOX;SMALL BROWN 9 3/16"X7"X1 1/4" - PACKOUT
9	1	PACKOUT	87-02163-000	N/A	?	ESD BAG;+;BAG; STATIC SHIELD ZIP 8"X10"; W/ ESD LOGO
10	1	PACKOUT	6.88E+11	WURTH ELECTRONICS INC.		WR_FFC 0.50mm TYPE 1 CABLE
TOTAL	16					

MAX30102 USBOSMB EV BOM

ITEM	QTY	REF DES	MFG PART #	MANUFACTURER	VALUE	DESCRIPTION	STATUS
1	1	C1	C0603C104K4RACAUTO	KEMET	0.1UF	CAPACITOR; SMT (0603); CERAMIC CHIP; 0.1UF; 16V; TOL=10%; TG=-55 DEGC TO +125 DEGC; TC=X7R AUTO	EVKIT-NOT FOR TEST
2	1	C2	GRM32ER71H106KA12L; CL32B106KBJNNN	MURATA; SAMSUNG ELECTRONICS	10UF	CAPACITOR; SMT (1210); CERAMIC CHIP; 10UF; 50V; TOL=10%; TG=-55 DEGC TO +125 DEGC; TC=X7R	ACTIVE
3	3	C3, C4, C8	UMK107AB7105KA	TAIYO YUDEN	1UF	CAPACITOR; SMT (0603); CERAMIC CHIP; 1UF; 50V; TOL=10%; TG=-55 DEGC TO +125 DEGC; TC=X7R	ACTIVE
4	3	C5, C9, C11	C1608X5R1E475K080AC	TDK	4.7UF	CAPACITOR; SMT (0603); CERAMIC CHIP; 4.7UF; 25V; TOL=10%; MODEL=C SERIES; TG=-55 DEGC TO +85 DEGC; TC=X5R	ACTIVE
5	1	C10	C1608C0G1H103J; CGA3E2C0G1H103J080AD; GRM1885C1H103JA01	TDK; MURATA	0.01UF	CAPACITOR; SMT (0603); CERAMIC CHIP; 0.01UF; 50V; TOL=5%; TG=-55 DEGC to +125 DEGC; TC=C0G	ACTIVE
6	1	DS1	HSMH-C190	AVAGO TECHNOLOGIES	HSMH-C190	DIODE; LED; SURFACE MOUNT CHIP LED; RED; SMT (0603); PIV=1.8V; IF=0.02A	EVKIT-NOT FOR TEST
7	1	DS2	HSMG-C190	AVAGO TECHNOLOGIES	HSMG-C190	DIODE; LED; SURFACE MOUNT CHIP LED; GREEN; SMT (0603); PIV=2.2V; IF=0.02A	EVKIT-NOT FOR TEST
8	1	J1	ZX62RD-AB-5P8	HIROSE ELECTRIC CO LTD.	ZX62RD-AB-5P8	CONNECTOR; MALE; SMT; MICRO-USB CONNECTOR MEETING REQUIREMENTS OF USB 2.0 STANDARD; RIGHT ANGLE; 5PINS	ACTIVE
9	1	J2	GRPB031VWVN-RC	SULLINS ELECTRONICS CORP.	GRPB031VWVN-RC	CONNECTOR; MALE; THROUGH HOLE; 0.050" SINGLE ROW MALE HEADER CONNECTOR; STRAIGHT; 3PINS; -40 DEGC TO +105 DEGC	EVKIT-NOT FOR TEST
10	1	J3	68711014522	WURTH ELECTRONICS INC.	68711014522	CONNECTOR; FEMALE; SMT; 0.5MM ZIF HORIZONTAL BOTTOM CONTACT WR-FPC; RIGHT ANGLE; 10PINS	EVKIT-NOT FOR TEST
11	3	R1, R4, R5	ERJ-2GEJ471X	PANASONIC	470	RESISTOR; 0402; 470 OHM; 5%; 200PPM; 0.10W; THICK FILM	EVKIT-NOT FOR TEST
12	6	R2, R3, R6-R8, R11	ERJ-2GEJ472X	PANASONIC	4.7K	RESISTOR; 0402; 4.7K OHM; 5%; 200PPM; 0.10W; THICK FILM	EVKIT-NOT FOR TEST
13	1	R9	CRCW040213K7FK	VISHAY DALE	13.7K	RESISTOR; 0402; 13.7K OHM; 1%; 100PPM; 0.063W; THICK FILM	ACTIVE
14	1	R10	CRCW040236K5FK	PANASONIC	36.5K	RESISTOR; 0402; 36.5K OHM; 1%; 100PPM; 0.063W; THICK FILM	EVKIT-NOT FOR TEST
15	1	U1	C8051F321	SILICON LABORATORIES	C8051F321	IC; CTRL; FULL SPEED USB, 16K ISP FLASH MCU FAMILY; QFN28-EP	EVKIT-NOT FOR TEST
16	1	U2	MAX3207EAUT+	MAXIM	MAX3207EAUT	IC; PROT; DUAL, QUAD, AND HEX HIGH-SPEED DIFFERENTIAL ESD-PROTECTION IC; SOT23-6	ACTIVE
17	1	U3	MAX8510EXK18	MAXIM	MAX8510EXK18	IC; VREG; ULTRA-LOW-NOISE; HIGH PSRR; LOW-DROPOUT; 0.12A LINEAR REGULATOR; SC70-5	ACTIVE
18	1	U5	MAX8512EXK	MAXIM	MAX8512EXK	IC, VREG, Ultra-Low-Noise, High PSRR, Adjustable Vout, SC70-5	ACTIVE
19	1		EPCB	MAX	MAXIM	PCB	PCB: MAX
TOTAL	30						

Revision History

REVISION NUMBER	REVISION DATE	DESCRIPTION	PAGES CHANGED
0	10/15	Initial Release	—
1	4/24	Updated <i>Quick Start</i> , <i>Procedure</i> , and <i>Component List</i> sections	1



Information furnished by Analog Devices is believed to be accurate and reliable. However, no responsibility is assumed by Analog Devices for its use, nor for any infringements of patents or other rights of third parties that may result from its use. Specifications subject to change without notice. No license is granted by implication or otherwise under any patent or patent rights of Analog Devices. Trademarks and registered trademarks are the property of their respective owners.