

## General Description

The MAX16165/MAX16166 evaluation kit (EV kit) monitors up to five voltages and sequences up to four voltages. The MAX16165 and MAX16166 provide an adjustable delay as each power supply is turned on as well as monitor each power supply voltage.

The MAX16166 EV kit comes with the MAX16166WPH+T installed. This product is RoHS compliant.

## Features

- 2.7V to 16.0V Wide Operating Voltage Range
- Monitor up to Five Voltages
- Sequence up to Four Voltages
- Configurable for MAX16165 and MAX16166
- EV Kit comes with LED Indicators for System Event
- Onboard LDO's are used for Sequencing/Monitoring
- Proven 4-Layer 1-oz Copper PCB Layout
- Demonstrates Compact Solution Size
- Fully Assembled and Tested

## MAX16165/MAX16166 EV Kit Files

FILE	DESCRIPTION
MAX16165/MAX16166 EV BOM	EVKIT BOM
MAX16165/MAX16166 EV PCB LAYOUT	EVKIT Layout
MAX16165/MAX16166 EV SCHEMATIC	EVKIT Schematic

[Ordering Information](#) appears at end of data sheet.

## Quick Start

### Required Equipment

- MAX16165/MAX16166 EV kit
- 25V, 1A DC Power supply
- Oscilloscope
- Digital voltmeter (DVM)

### Procedure

The EV kit is fully assembled and tested. Follow the steps and make the required hardware connections to start operation of the kit.

**Caution: Do not turn on the power supply until all connections are completed.**

1. Verify that shunt J1, J2, JSET\_, JEN\_, JIN\_, JLOAD, UVSET, and JPULLUP are configured as in [Table 1](#) and [Table 3](#).
2. If the VDD is more than 5V, do not install shunt in J2.
3. Connect the positive terminal of power supply to the VDD test point.
4. Adjust the voltage to 5V and turn on the VDD power supply.
5. Check the FAULT indicator LED and make sure it is not turned on.
6. Remove shunt from J1(2:3) and connect to J1(1:2) to initiate the power-on sequencing.
7. Verify that the status LEDs indicate the correct state of all OUT\_, DONE, and POK outputs during power-on sequencing.
8. Once power-on sequencing is completed, remove shunt from J1(1:2) and connect to J1(2:3) to initiate power-down sequencing.

EV Kit Photo

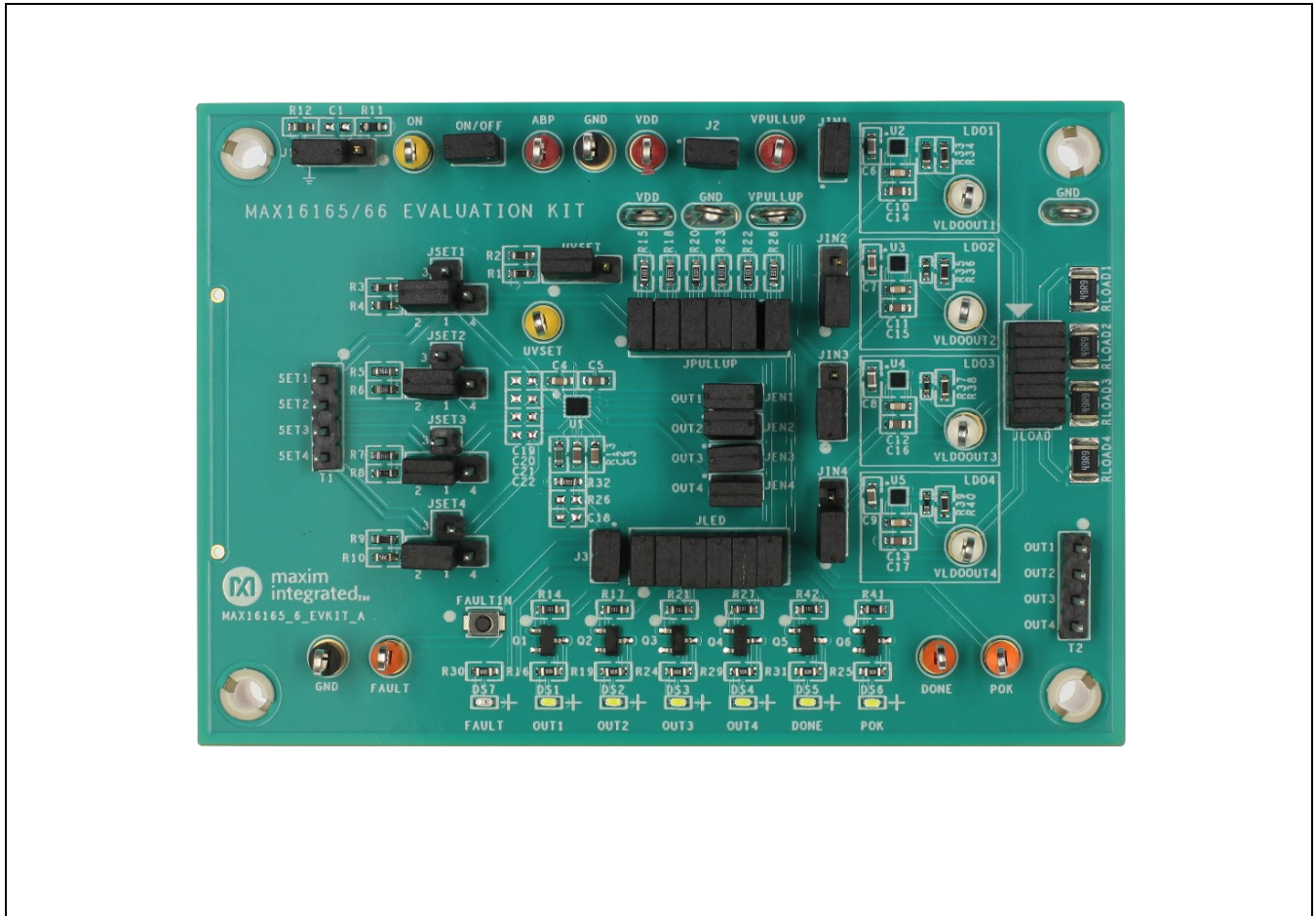

Figure 1. MAX16165/MAX16166 EV Kit Board Connections

**Table 1. MAX16165/MAX16166 EV Kit Jumper Description**

JUMPER		SIGNAL	SHUNT POSITION	DESCRIPTION
MAX16165	MAX16166			
J1	J1	VPULLUP	1-2	Power-up sequencing
			2-3*	Power-down sequencing
			Not Installed	Power-up and power-down sequencing using programmable controllers
J2	J2	VDD	1-2*	Connects VDD to VPULLUP
			Not Installed	If VDD > 5V, an additional power supply is needed for VPULLUP
J3	J3	FAULT	1-2*	Enables LED Indicator for FAULT
JSET1	JSET1	SET1	1-2*	Feedback from VLDOOUT1
			1-3	ABP is connected to SET1, skips OUT1/disables channel 1
			1-4	OUT1 is connected to SET1
JSET2	JSET2	SET2	1-2*	Feedback from VLDOOUT2
			1-3	ABP is connected to SET2, skips OUT2/disables channel 2
			1-4	OUT2 is connected to SET2
JSET3	JSET3	SET3	1-2*	Feedback from VLDOOUT3
			1-3	ABP is connected to SET3, skips OUT3/disables channel 3
			1-4	OUT3 is connected to SET3
JSET4	JSET4	SET4	1-2*	Feedback from VLDOOUT4
			1-3	ABP is connected to SET4, skips OUT4/disables channel 4
			1-4	OUT4 is connected to SET4
JIN1	JIN1	U2_IN	1-2*	VPULLUP is connected to LDO input
JIN2	JIN2	U3_IN	1-2	VPULLUP is connected to LDO input
			2-3*	VLDOOUT1 is connected to LDO input
JIN3	JIN3	U4_IN	1-2	VPULLUP is connected to LDO input
			2-3*	VLDOOUT2 is connected to LDO input
JIN4	JIN4	U5_IN	1-2	VPULLUP is connected to LDO input
			2-3*	VLDOOUT3 is connected to LDO input
JEN1	JEN1	EN	1-2*	Connects OUT1 with EN of U2
			Not Installed	Sequencer only operation; DC-DC mode with feedback from LDO is disabled
JEN2	JEN2		1-2*	Connects OUT2 with EN of U3

			Not Installed	Sequencer only operation; DC-DC mode with feedback from LDO is disabled
JEN3	JEN3		1-2*	Connects OUT3 with EN of U4
			Not Installed	Sequencer only operation; DC-DC mode with feedback from LDO is disabled
JEN4	JEN4		1-2*	Connects OUT4 with EN of U5
			Not Installed	Sequencer only operation; DC-DC mode with feedback from LDO is disabled
JLOAD	JLOAD	VLDOOUT_	1-2*	Connects VLDOOUT1 with RLOAD1
			3-4*	Connects VLDOOUT2 with RLOAD2
			5-6*	Connects VLDOOUT3 with RLOAD3
			7-8*	Connects VLDOOUT4 with RLOAD4
JPULLUP		OUT_	1-2	Connects OUT1 with PULLUP resistor
			3-4	Connects OUT2 with PULLUP resistor
			5-6	Connects OUT3 with PULLUP resistor
			7-8	Connects OUT4 with PULLUP resistor
		DONE	9-10	Connects DONE with PULLUP resistor
		POK	11-12	Connects POK with PULLUP resistor
JLED	JLED	OUT_	1-2*	Enables LED indicator for OUT1
			3-4*	Enables LED indicator for OUT2
			5-6*	Enables LED indicator for OUT3
			7-8*	Enables LED indicator for OUT4
		DONE	9-10*	Enables LED indicator for DONE
		POK	11-12*	Enables LED indicator for POK

\*Default position

## Detailed Description of Hardware

The MAX16165/MAX16166 EV kit demonstrates the sequencer operation of four power supplies during turn-on and turn-off. During turn-off, the sequencer disables these four power supplies in reverse order.

The EV kit should be used with the following documents:

- MAX16165/MAX16166 data sheet
- MAX16165/MAX16166 EV kit data sheet (this document)

## Sequencer Operation

### 1. Power-On Sequencing

When the sequencer initiates power-on sequencing, the MAX16165/MAX16166 provide a capacitor-adjustable delay time ( $t_{DLY}$ ) before the first output is enabled. Connect a capacitor (C2) between DLY and GND to adjust the sequencing delay period ( $t_{DLY}$ ) that occurs between sequenced channels. Use the following formula to estimate the delay:

$$t_{DLY} = 125k\Omega \times C2$$

where  $t_{DLY}$  is in seconds and C2 is in Farads. Leave DLY unconnected for the minimum 40 $\mu$ s (typ) delay. After each  $t_{DLY}$  the DLY capacitor discharges (internal 4 $\Omega$ ) with 40 $\mu$ s. The accuracy of  $t_{DLY}$  is affected by the C2 capacitor leakage and tolerance. A low-leakage ceramic capacitor is recommended.

In the EV kit, the sequencing delay period ( $t_{DLY}$ ) is 275ms.

### 2. Power-Off Sequencing

When the sequencer initiates power-off sequencing, an offset current  $I_{OFFSET}$  is injected into the SET\_ pins, and the MAX16165/MAX16166 provide the delay time  $t_{DLY}$  before the fourth output is disabled. Connect a resistor (R13) between IOS and GND to decide the  $I_{OFFSET}$  of all the channels. Use the following formula to calculate the  $R_{IOS}$  (R13) for an offset current  $I_{OFFSET}$ :

$$R_{IOS} = \left( \frac{0.5V}{I_{OFFSET}} \right)$$

In the EV kit, the offset current value is 10 $\mu$ A.

### 3. Sequencer Only Operation

To operate in this mode, do not install the jumper JEN\_. JEN1, JEN2, JEN3, and JEN4 should be kept floating. This isolates the LDO's connection with MAX16165/MAX16166 IC. See [Table 1](#) for a connection guide.

**Table 2. LED Indicator Status**

STATUS LED	DESCRIPTION
DS1 (OUT1)	This Green LED indicates the status of OUT1, turns on when it is HIGH.
DS2 (OUT2)	This Green LED indicates the status of OUT2, turns on when it is HIGH.
DS3 (OUT3)	This Green LED indicates the status of OUT3, turns on when it is HIGH.
DS4 (OUT4)	This Green LED indicates the status of OUT4, turns on when it is HIGH.
DS5 (DONE)	This Green LED indicates the status of DONE, turns on when it is HIGH.
DS6 (POK)	This Green LED indicates the status of POK, turns on when it is HIGH.
DS7 (FAULT)	This Red LED indicates the status of FAULT, turns on when it is LOW.

## UVSET

The MAX16165/MAX16166 also monitor UVSET input for an undervoltage condition after power-up. UVSET is supplied with VDD through a resistor divider R1 and R2 on the EV kits. R1 and R2 are configured to obtain approximately 0.5V at the UVSET pin.

**Table 3. UVSET Jumper Description/Connection Guide**

JUMPER	SHUNT POSITION	DESCRIPTION
UVSET	1-2*	Connects VDD power supply to UVSET through resistor divider
	2-3	Connects ABP to UVSET

\*Default position

## FAULT Input/Output

FAULT is bidirectional. It is active low input and active low open-drain output. Refer to the MAX16165/MAX16166 data sheet for all conditions that assert a FAULT.

**Note:** If extended fault pulse width is desired, mount R26 and C18 to avoid channel skipping during initialization.

## SKIP or DISABLE Channels

If fewer than four channels are required, skip a channel by connecting the SET\_ pin to ABP pin. The sequencing is similar with four channel sequencing, proceed as though the MAX16165/MAX16166 has fewer channels (e.g., if SET2 is connected to ABP, all logic for channel 2 is removed from the state machine; no delay, no timer, no UV detection, and no fault triggered from this channel). If all channels are skipped, the device asserts DONE and POK immediately after initialization.

## Power Good Timer and Power Timer Input (PGT)

The Power Good Timer is used to check the capability of a power supply to reach a set voltage within a capacitor adjustable delay ( $t_{PGT}$ ). Connect a capacitor (C3) between PGT and GND to adjust the sequencing delay period ( $t_{PGT}$ ) on the EV kit. Use the following formula to estimate the delay:

$$t_{PGT} = 5\mu s + 125k\Omega \times C3$$

where  $t_{PGT}$  is in seconds and C3 is in Farads. Leave PGT unconnected for a minimum 5 $\mu$ s (typ) delay. The accuracy of the delay is affected by the C3 capacitor leakage and tolerance. A low-leakage ceramic capacitor is recommended.

In the EV kit, the sequencing delay period ( $t_{PGT}$ ) is 125ms.

## Open-Drain and Push-pull Outputs

The MAX16165 has open-drain outputs whereas the MAX16166 has push-pull outputs. Pullup resistors are required for open-drain outputs. The exact value of the pullup resistors for the open-drain outputs is not critical, but some consideration should be made to ensure the proper logic levels when the device is sinking current. For example, if VDD = 3.3V and the pullup voltage is 5V, keep the sink current less than 3.2mA as shown in the *Electrical Characteristics* table of MAX16165/16166 datasheet. As a result, the pullup resistor should be greater than 1.6k $\Omega$ . For a 12V pullup, the resistor should be larger than 3.74k $\Omega$ .

In the EV kit, R15, R18, R20, R22, R23, and R28 are pullup resistors, and their values are set to 10k $\Omega$ .

## SET\_IN Threshold and LDO Output Setting

The EV kit input-voltage thresholds are set to operate with 3.6V, 3.3V, 2.5V, and 1.8V (MAX16165/MAX16166) voltage systems. All input-voltage thresholds can be reconfigured by replacing the corresponding resistors R33, R34, R35, R36, R37, and R38 as shown in [Figure 1](#). Refer to the *Applications Information* section of the MAX16165/MAX16166 IC data sheet and Resistor Value Selection section in the MAX38903 IC data sheet to calculate the new resistor values when reconfiguring the EV kit input thresholds.

## Ordering Information

PART	TYPE
MAX16166EVKIT#	EV KIT
MAX16165EVKIT#*	EV KIT

#Denotes a RoHS-compliant device that may include lead(Pb) that is exempt under the RoHS requirements.

\*Future product—contact factory for availability.

## MAX16165/MAX16166 EV Kit Bill of Materials

ITEM	REF_DES	QTY	MFG PART#	MANUFACTURER	VALUE	DESCRIPTION
1	ABP, VDD, VPULLUP	3	5010	KEystone	N/A	TEST POINT; PIN DIA=0.125IN; TOTAL LENGTH=0.445IN; BOARD HOLE=0.063IN; RED;
2	C2	1	GCM188R70J225KE22J	MURATA	2.2UF	CAP; SMT (0603); 2.2UF; 10%; 6.3V; X7R; CERAMIC
3	C3, C5	2	C0603C105K9RACAUTO	KEMET	1UF	CAP; SMT (0603); 1UF; 10%; 6.3V; X7R; CERAMIC
4	C4	1	885012206071;C1608X7R1E104K080AA;C0603C104K3RAC	WURTH ELECTRONICS INC;TDK	0.1UF	CAP; SMT (0603); 0.1UF; 10%; 25V; X7R; CERAMIC
5	C6-C9, C14-C17	8	CL10B106MQ8NRN	SAMSUNG ELECTRONICS	10UF	CAP; SMT (0603); 10UF; 20%; 6.3V; X7R; CERAMIC
6	C10-C13	4	C0603C473K5RAC; GRM188R71H473KA61; GCM188R71H473KA55	KEMET;MURATA;MURATA	0.047UF	CAP; SMT (0603); 0.047UF; 10%; 50V; X7R; CERAMIC
7	DONE, FAULT, POK	3	5013	KEystone	N/A	TEST POINT; PIN DIA=0.125IN; TOTAL LENGTH=0.445IN; BOARD HOLE=0.063IN; ORANGE;
8	DS1-DS6	6	KP DELPS1.FP-JGVI-34-Z555	OSRAM	-	LED; PURE GREEN; SMT; VF=2.9V; IF=0.01A
9	DS7	1	KS DELPS1.22-TIVH-68-H3Q4	OSRAM	-	LED; SUPER RED; SMT; VF=2.2V; IF=0.02A
10	FAULTIN	1	B3U-1000P	OMRON	-	SWITCH; SPST; SMT; STRAIGHT; 12V; 0.05A; ULTRA-SMALL TACTILE SWITCH
11	GND, GND1, VDD1, VPULLUP1	4	9020 BUSS	WEICO WIRE	-	EVK KIT PARTS; MAXIM PAD; WIRE; NATURAL; SOLID; SOFT DRAWN BUS TYPE-S; 20AWG
12	J1, JIN2-JIN4, UVSET	5	PCC03SAAN	SULLINS	-	CONNECTOR; MALE; THROUGH HOLE; BREAKAWAY; STRAIGHT THROUGH; 3PINS;
13	J2, J3, JEN1-JEN4, JIN1, ON/OFF	8	PEC02SAAN	SULLINS	-	CONNECTOR; MALE; THROUGH HOLE; BREAKAWAY; STRAIGHT; 2PINS
14	JLED, JPULLUP	2	PEC06DAAN	SULLINS ELECTRONICS CORP.	-	CONNECTOR; MALE; THROUGH HOLE; BREAKAWAY; STRAIGHT; 12PINS
15	JLOAD	1	PEC04DAAN	SULLINS ELECTRONICS CORP.	-	CONNECTOR; MALE; THROUGH HOLE; BREAKAWAY; STRAIGHT; 8PINS
16	MH1-MH4	4	9032	KEystone	9032	MACHINE FABRICATED; ROUND-THRU HOLE SPACER; NO THREAD; M3.5; 5/8IN; NYLON
17	ON, TP3	2	5014	KEystone	N/A	TEST POINT; PIN DIA=0.125IN; TOTAL LENGTH=0.445IN; BOARD HOLE=0.063IN; YELLOW;
18	Q1-Q6	6	ZXTN25020DFH	DIODES INCORPORATED	-	TRAN; 20V SOT23 NPN MEDIUM POWER TRANSISTOR; NPN; SOT-23; PD-(1.25W); I-(4.5A); V-(20V)
19	R1, R34, R36, R38, R40	5	ERJ-PA3F3003	PANASONIC	300K	RES; SMT (0603); 300K; 1%; +/- 100PPM/DEGC; 0.2500W

20	R2	1	ERJ-3EKF3572	PANASONIC	35.7K	RES; SMT (0603); 35.7K; 1%; +/- 100PPM/DEGC; 0.1000W
21	R3	1	CRCW0603261KFK	VISHAY DALE	261K	RES; SMT (0603); 261K; 1%; +/- 100PPM/DEGC; 0.1000W
22	R4	1	CRCW060345K3FK;	VISHAY DALE	45.3K	RES; SMT (0603); 45.3K; 1%; +/- 100PPM/DEGC; 0.1000W
23	R5	1	CRCW0603232KFK	VISHAY DALE	232K	RES; SMT (0603); 232K; 1%; +/- 100PPM/DEGC; 0.1000W
24	R6	1	ERJ-3EKF4422	PANASONIC	44.2K	RES; SMT (0603); 44.2K; 1%; +/- 100PPM/DEGC; 0.1000W
25	R7	1	ERJ-3EKF1543	PANASONIC	154K	RES; SMT (0603); 154K; 1%; +/- 100PPM/DEGC; 0.1000W
26	R8	1	CRCW060341K2FK	VISHAY DALE	41.2K	RES; SMT (0603); 41.2K; 1%; +/- 100PPM/DEGC; 0.1000W
27	R9	1	ERA-3AEB8872	PANASONIC	88.7K	RES; SMT (0603); 88.7K; 0.10%; +/- 25PPM/DEGC; 0.1000W
28	R10	2	CRCW060337K4FK	VISHAY	37.4K	RES; SMT (0603); 37.4K; 1%; +/- 100PPM/DEGC; 0.1000W
29	R11,R12	1	CRCW060310K0FK;ERJ-3EKF1002;AC0603FR-0710KL;RMC0603FT10K0	VISHAY DALE;PANASONIC;YAGEO	10K	RES; SMT (0603); 10K; 1%; +/- 100PPM/DEGC; 0.1000W
30	R13	6	PNM0603E5002BS	VISHAY DALE	50K	RES; SMT (0603); 50K; 0.10%; +/- 25PPM/DEGC; 0.1500W
31	R14, R17, R21, R27, R41, R42	6	ERJ-3GEYJ102	PANASONIC	1K	RES; SMT (0603); 1K; 5%; +/-200PPM/DEGC; 0.1000W
32	R15, R18, R20, R22, R23, R28	7	301-10K-RC	XICON	10K	RES; SMT (0603); 10K; 5%; +/- 200PPM/DEGC; 0.0630W
33	R16, R19, R24, R25, R29-R31	1	RNCP0603FTD2K00	STACKPOLE ELECTRONICS INC.	2K	RES; SMT (0603); 2K; 1%; +/-100PPM/DEGC; 0.1250W
34	R32	1	CRCW0603100KFK	VISHAY DALE	100K	RES; SMT (0603); 100K; 1%; +/- 100PPM/DEGC; 0.1000W
35	R33	1	CRCW06031M50FK	VISHAY DALE	1.5M	RES; SMT (0603); 1.5M; 1%; +/- 100PPM/DEGC; 0.1000W
36	R35	1	RC0402FR-071M33L	YAGEO	1.33M	RES; SMT (0402); 1.33M; 1%; +/- 100PPM/DEGC; 0.0630W
37	R37	1	CRCW0402953KFKEDC; RC0402FR-07953KL	VISHAY;YAGEO	953K	RES; SMT (0402); 953K; 1%; +/- 100PPM/DEGC; 0.0630W;
38	R39	1	ERJ-2RKF6043	PANASONIC	604K	RES; SMT (0402); 604K; 1%; +/- 100PPM/DEGC; 0.1000W
39	RLOAD1-RLOAD4	4	ERJ-14NF49R9	PANASONIC	49.9	RES; SMT (1210); 49.9; 1%; +/- 100PPM/DEGC; 0.5000W
40	SU1-SU33	33	STC02SYAN	SULLINS ELECTRONICS CORP.	-	CONNECTOR; MALE; THROUGH HOLE; BREAKAWAY; STRAIGHT; 4PINS
41	JSET1-JSET4, T1, T2	6	PEC04SAAN	SULLINS ELECTRONICS CORP.	-	CONNECTOR; MALE; THROUGH HOLE; BREAKAWAY; STRAIGHT; 4PINS
42	TP1, TP2	2	5011	KEYSTONE	N/A	TEST POINT; PIN DIA=0.125IN; TOTAL LENGTH=0.445IN; BOARD HOLE=0.063IN; BLACK

43	U1	1	MAX16166AHWP+	MAXIM	MAX16166AHWP+	EVKIT PART - IC; PWRM; QUAD POWER SUPPLY SEQUENCER AND SUPERVISOR; PACKAGE CODE: W201C2+2; PACKAGE OUTLINE DRAWING: 21-100553; WLP20
44	U2-U5	4	MAX38903CANL+	MAXIM	MAX38903CANL+	IC; REG; 1.7V-5.5VIN; 1A LOW NOISE LDO LINEAR REGULATORS; WLP9
45	VLDOOUT1- VLDOOUT4	4	5012	KEystone	N/A	TEST POINT; PIN DIA=0.125IN; TOTAL LENGTH=0.445IN; BOARD HOLE=0.063IN; WHITE
46	C18-C22	0	885012206071	WURTH ELECTRONICS INC	0.1UF	CAP; SMT (0603); 0.1UF; 10%; 25V; X7R; CERAMIC
47	R26	0	RNCP0603FTD100R	STACKPOLE ELECTRONICS INC	100	RES; SMT (0603); 100; 1%; +/- 100PPM/DEGC; 0.1250W
48	C1	0	N/A	N/A	OPEN	PACKAGE OUTLINE 0603 NON-POLAR CAPACITOR

MAX16165/MAX16166 EV Kit Schematics

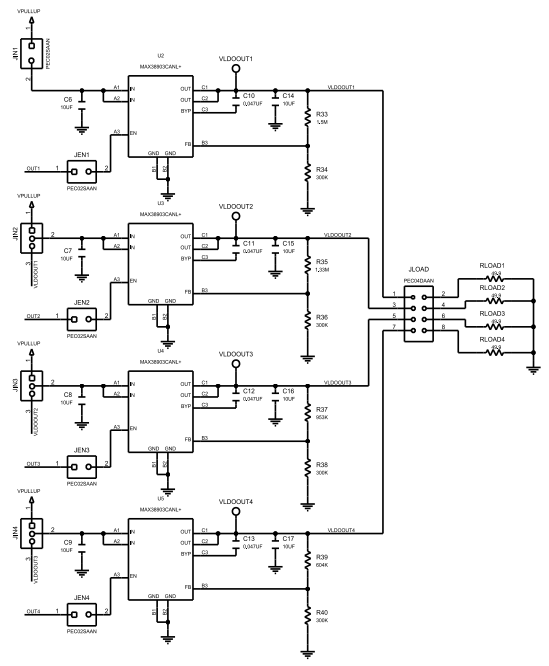
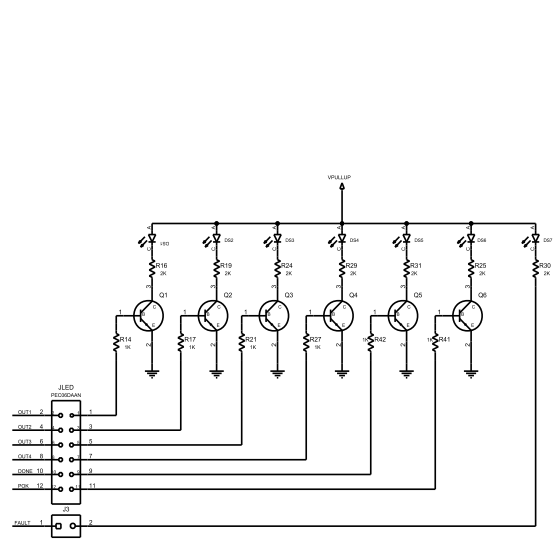
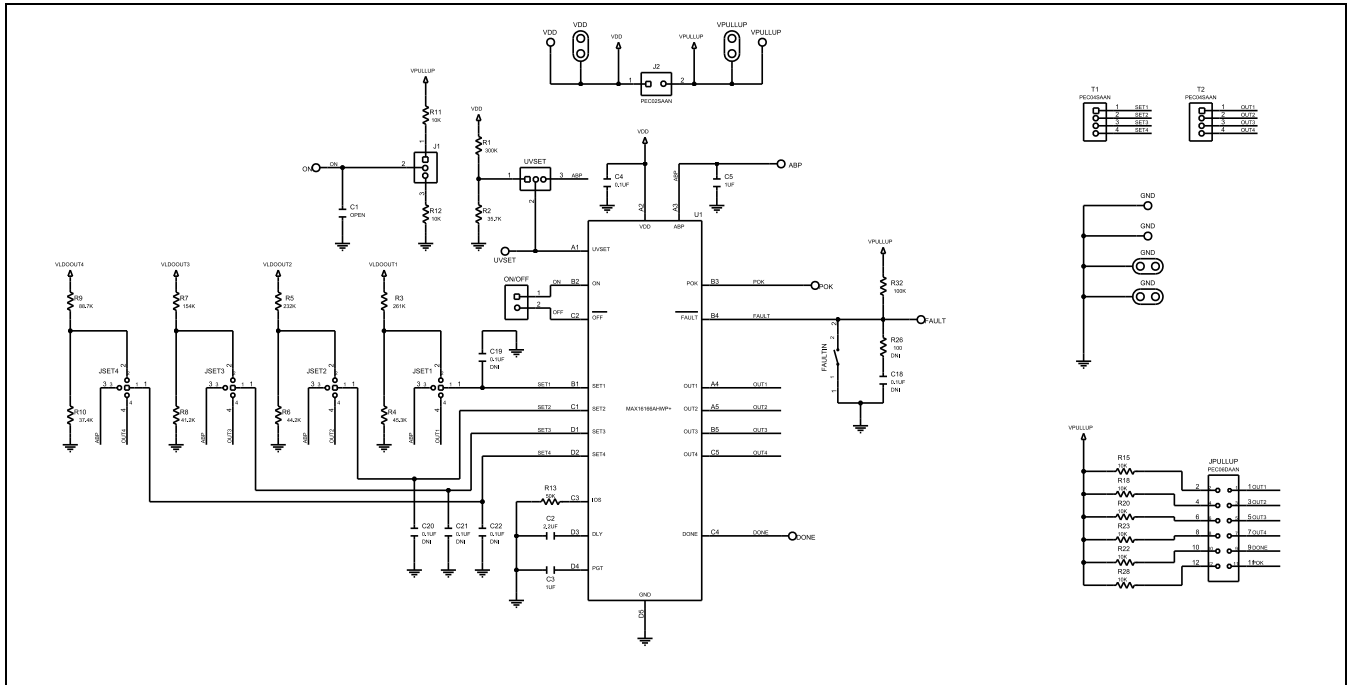

Figure 2.

MAX16165/MAX16166 EV Kit PCB Layout

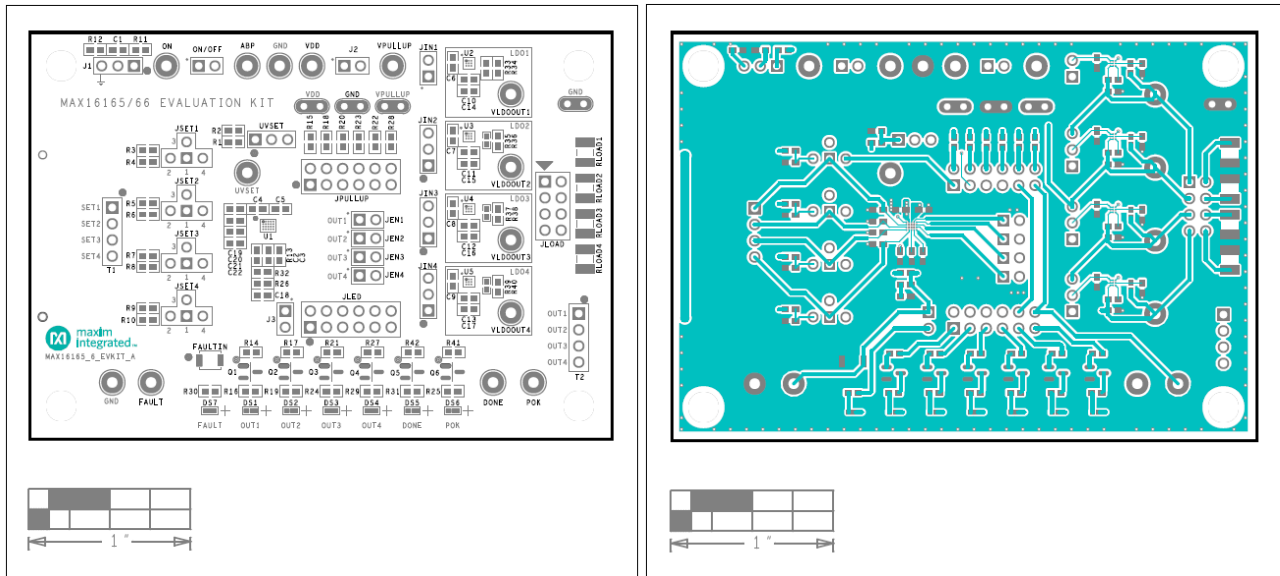
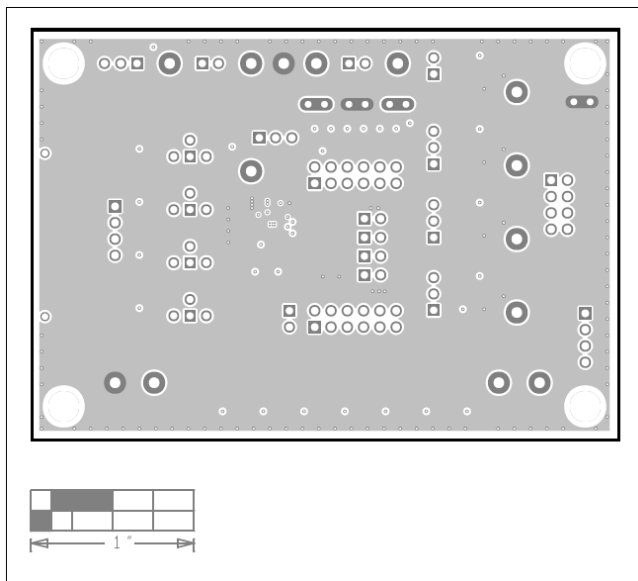
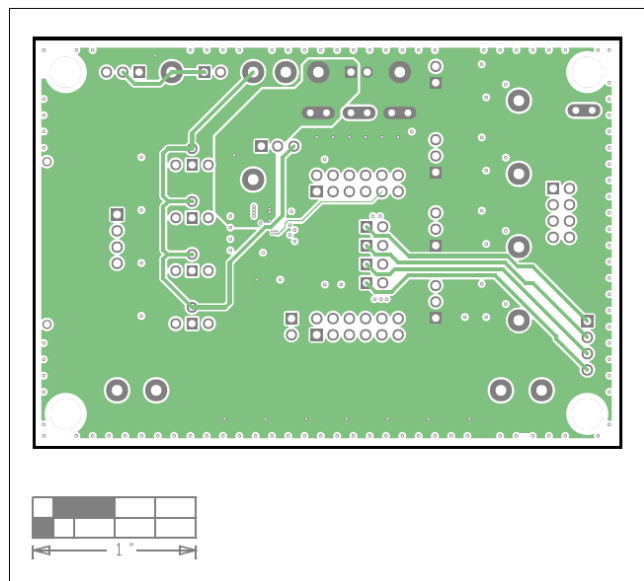

Figure 3. MAX16165/MAX16166 EV Kit PCB Layout—Top Silkscreen      MAX16165/MAX16166 EV Kit PCB Layout—Top



MAX16165/MAX16166 EV Kit PCB Layout—Layer 2



MAX16165/MAX16166 EV Kit PCB Layout—Layer 3

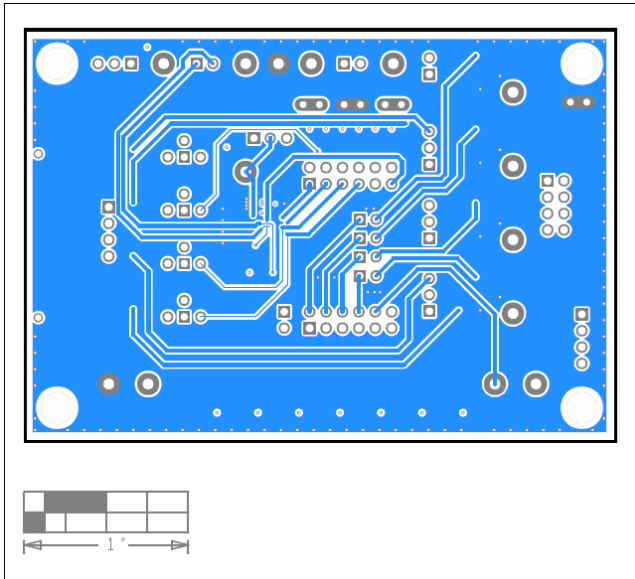

MAX16165/MAX16166 EV Kit PCB Layout—Bottom Silkscreen

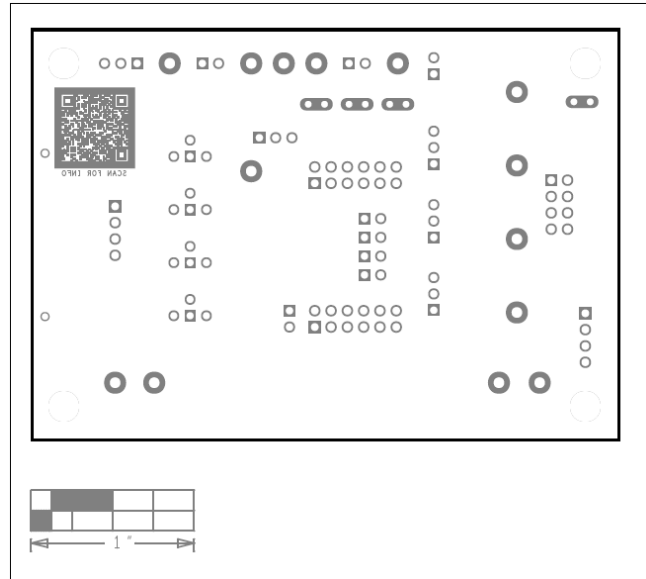

MAX16165/MAX16166 EV Kit PCB Layout—Bottom

## Revision History

REVISION NUMBER	REVISION DATE	DESCRIPTION	PAGES CHANGED
0	8/21	Release for Market Intro	—
1	6/24	Updated the Detailed Description of Hardware section	5-6

