

## SEK-19 SV HT MA LP ANG29 20P PL2 VC/RE/B

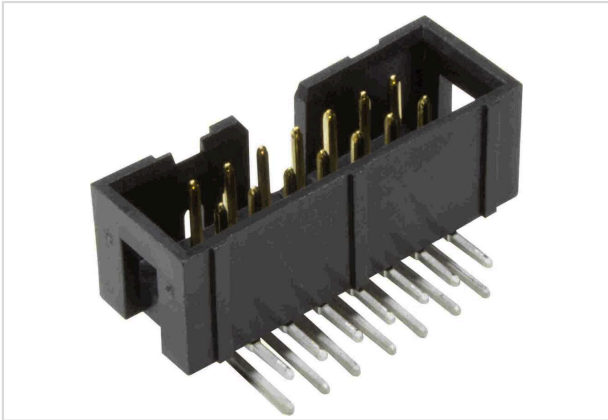

Image is for illustration purposes only. Please refer to product description.

Part number	09 19 520 6323 741
Specification	SEK-19 SV HT MA LP ANG29 20P PL2 VC/RE/B
HARTING eCatalogue	<a href="https://b2b.harting.com/09195206323741">https://b2b.harting.com/09195206323741</a>

### Identification

Category	Connectors
Series	SEK Low-profile
Element	Male connector
Description of the contact	Angled

### Version

Termination method	Reflow soldering termination (THR)
Connection type	PCB to cable Motherboard to daughtercard
Number of contacts	20
Termination length	2.9 mm
Pack contents	Tape & reel

### Technical characteristics

Contact rows	2
Contact spacing (termination side)	2.54 mm
Rated current	1 A
Insulation resistance	$>10^9 \Omega$
Contact resistance	$\leq 20 \text{ m}\Omega$
Limiting temperature	-55 ... +125 °C (during reflow soldering max. +240 °C for 60 s)
Insertion force	$\leq 40 \text{ N}$
Withdrawal force	$\leq 40 \text{ N}$
Performance level	2 acc. to IEC 60603-13



Pushing Performance  
Since 1945

## Technical characteristics

Mating cycles	≥250
Test voltage $U_{r.m.s.}$	1 kV
Isolation group	II ( $400 \leq CTI < 600$ )

## Material properties

Material (insert)	Thermoplastic resin (PCT)
Colour (insert)	Black
Material (contacts)	Copper alloy
Surface (contacts)	Noble metal over Ni Mating side Sn over Ni Termination side
Material flammability class acc. to UL 94	V-0
RoHS	compliant
ELV status	compliant
China RoHS	e
REACH Annex XVII substances	Not contained
REACH ANNEX XIV substances	Not contained
REACH SVHC substances	Not contained

## Specifications and approvals

Specifications	IEC 60603-13
UL / CSA	UL 1977 ECBT2.E102079 CSA-C22.2 No. 182.3 ECBT8.E102079

## Commercial data

Packaging size	280
Net weight	5.2 g
Country of origin	Romania
European customs tariff number	85366990
GTIN	5713140212121
ETIM	EC002637
eCl@ss	27460201 PCB connector (board connector)



**Pushing Performance**  
Since 1945

Cross section of solder termination

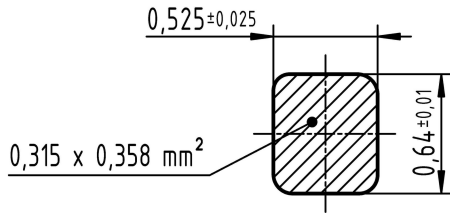

Reel dimensions

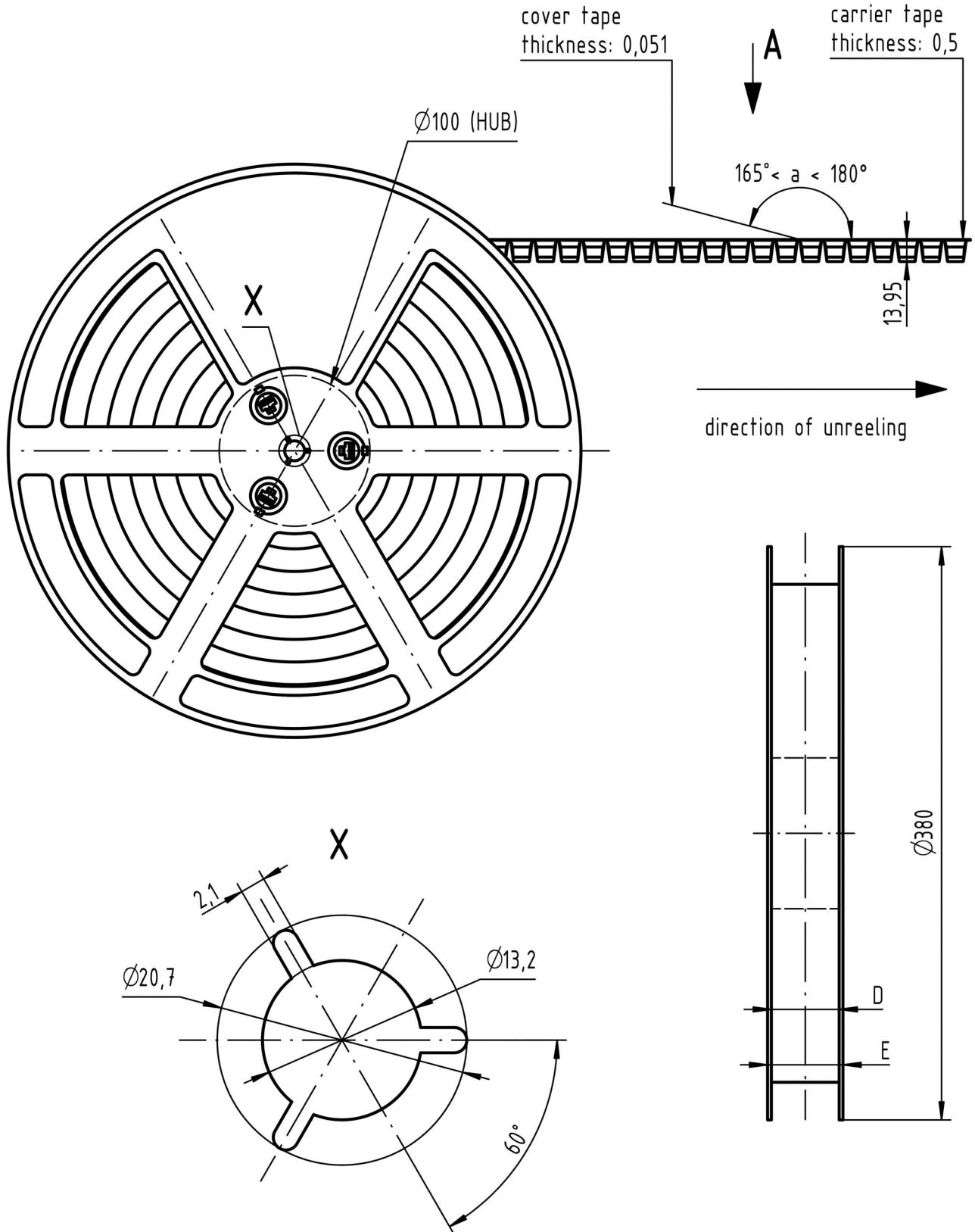

Tape layout & packaging

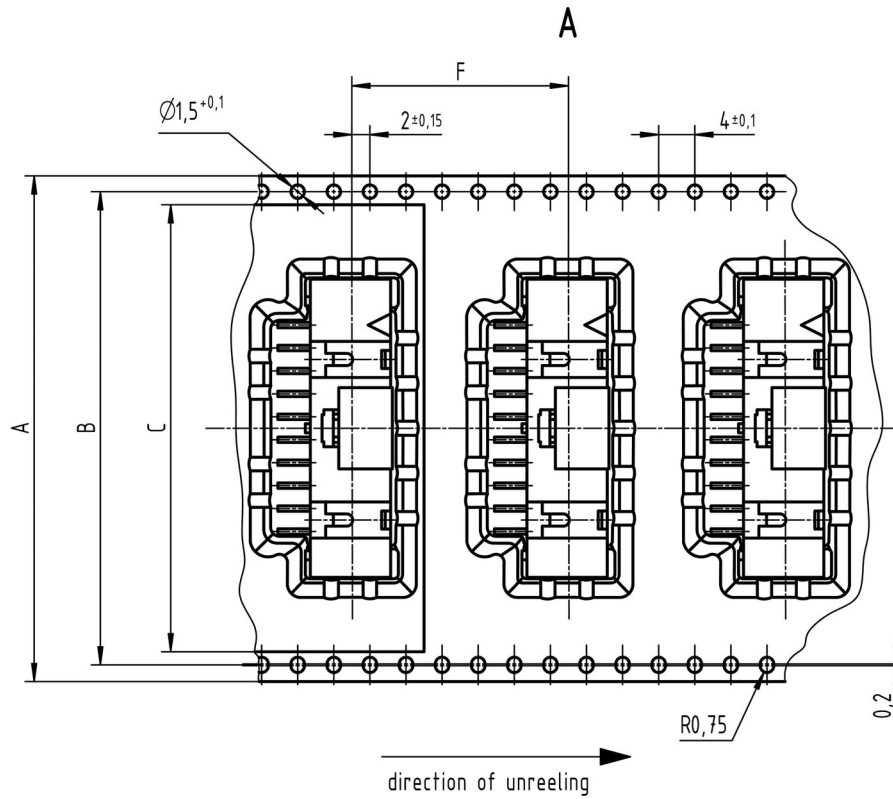

contacts	A	B	C	D	E	F	-trailer- number of empty cavities	number of connector per reel	-leader- number of empty cavities
40	72	68,4	65,5	73	78	24	14	280	16
34	72	68,4	65,5	73	78	24	14	280	16
30	56	52,4	49,5	57	62	24	14	280	16
26	56	52,4	49,5	57	62	24	14	280	16
20	56	52,4	49,5	57	62	24	14	280	16
16	44	40,4	37,5	45	50	24	14	280	16
14	44	40,4	37,5	45	50	24	14	280	16
10	44	40,4	37,5	45	50	24	14	280	16
6	32	28,4	25,5	33	38	24	14	280	16