

REVISIONS					
REV	ECO	DESCRIPTION	DATE	BY	APPR
A1	-	RELEASE NEW DRAWING	28/MAR/22	MILO	TOMMY

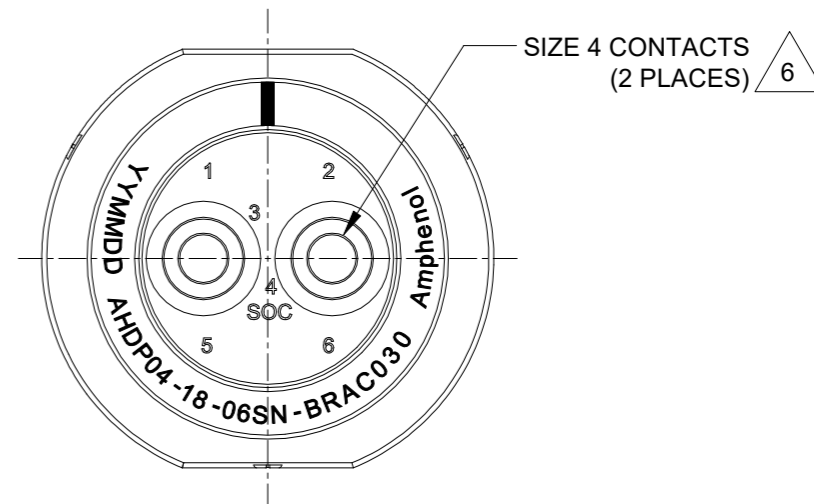
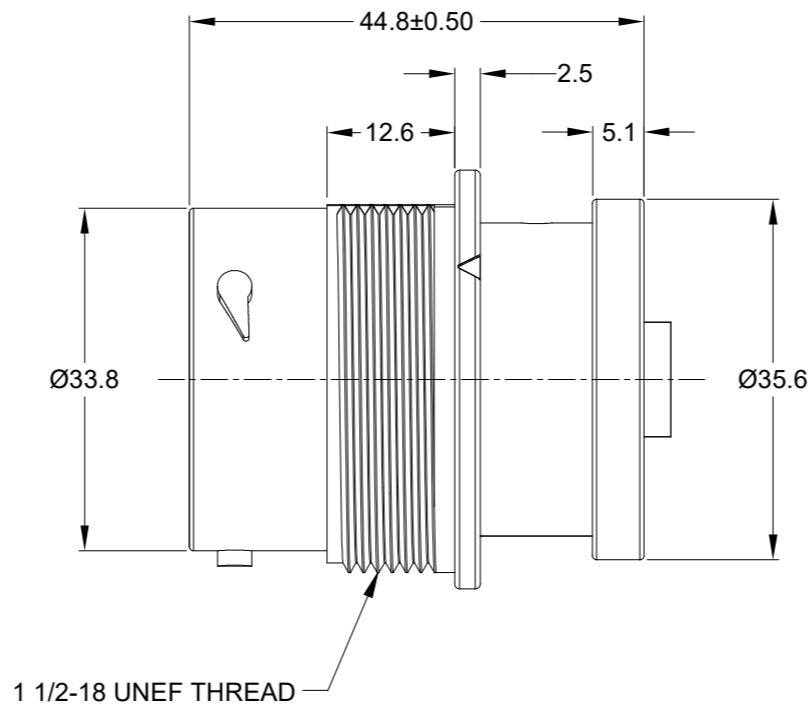
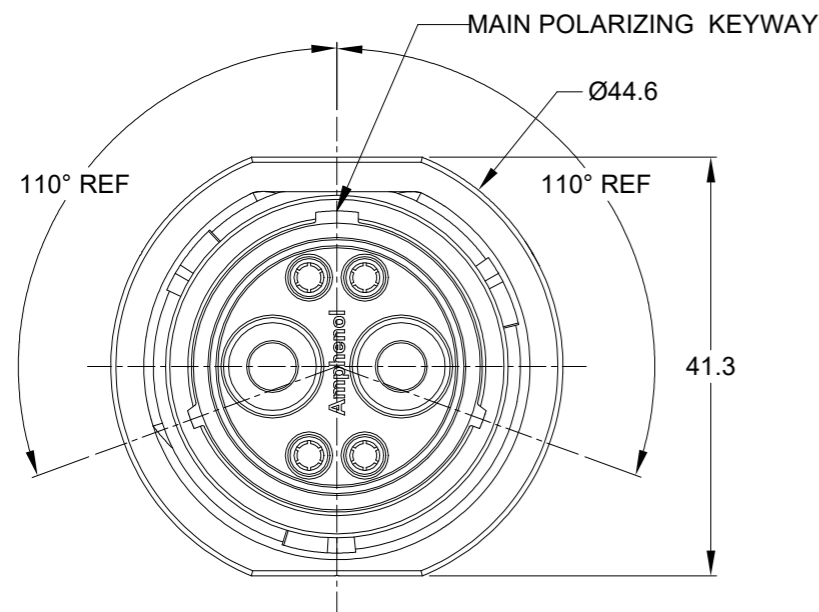

NOTES: UNLESS OTHERWISE SPECIFIED

- MATERIAL:
HOUSING: THERMOPLASTIC; BLACK
SEAL: SILICONE RUBBER
- MODIFICATIONS: BACKSHELL RING ADAPTER (BRA);
STANDARD DIA. WIRE SEAL
- SPECIFICATIONS:
 - OPERATING TEMPERATURE: -55°C TO +125°C.
 - DIELECTRIC WITHSTANDING VOLTAGE: LESS THAN 2 MILLIAMPS CURRENT LEAKAGE @ 1500 VOLTS AC.
 - INSULATION RESISTANCE: 1000 MEGOHM MIN @ 25°C.
 - MOISTURE RESISTANCE:
IP68(IM OF WATER FOR A PERIOD OF 24 HOURS, MATED CONDITION);
IP69K(MATED CONDITION).
 - MATING CYCLE DURABILITY: 100 CYCLES
 - RoHS COMPLIANT
- MATING PART: AHDP06-18-06P* (* = SEAL TYPE) (C030 OPTION)
- ALL DIMENSIONS ARE FOR REFERENCE USE ONLY.

Ø38.29±0.12

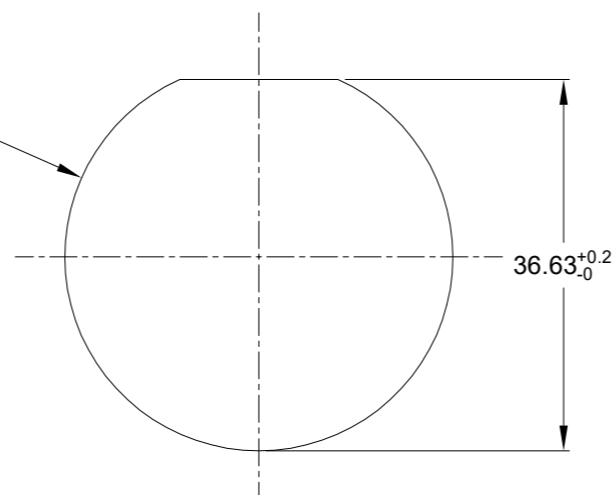

RECOMMENDED PANEL MOUNTING HOLE

RECOMMENDED PANEL THICKNESS: 1.6 TO 4.7MM

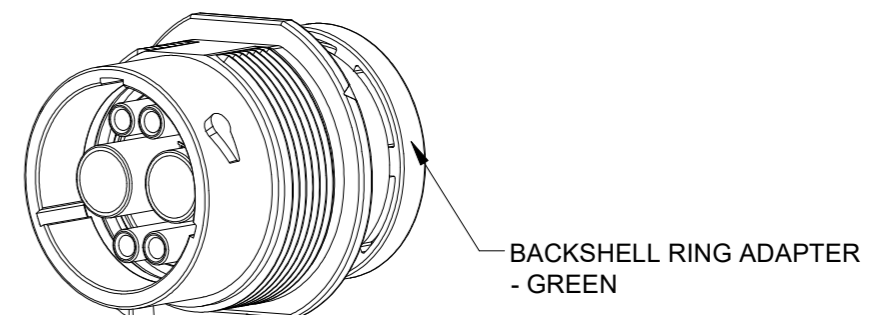

BACKSHELL RING ADAPTER - GREEN

6 CONTACT SIZE AND WIRE RANGE:

CONTACT SIZE	MIN. INSUL O.D.	MAX. INSUL O.D.	TYPICAL WIRE RANGE	CURRENT RATING
4	6.63 mm (.261in)	7.42 mm (.292 in)	6 AWG (16.0-13.0mm ²)	100 AMPS

QUANTITY	PART NUMBER	DESCRIPTION	ITEM
	AHDP04-18-06SN-BRAC030		

SIGNATURES			DATE
DRAWN:	MILO		28/MAR/22
CHECKED:	SULLEN		29/MAR/22
ENGINEER:			
APPROVAL:	TOMMY		30/MAR/22

MATERIALS LIST			
UNLESS OTHERWISE SPECIFIED 1) All dimensions are in metric(mm). 2) Tolerances are as follows: 1 PL DEC ±0.30 Fractions ±1/64 2 PL DEC ±0.15 Angles ±1° 3 PL DEC ±0.08 3) Note reference = X			
MATERIAL SPECIFICATIONS:		CUSTOMER:	
WEIGHT: 40.6g			
PROCESS SPECIFICATIONS:		THIS DRAWING IS SUPPLIED FOR INFORMATION ONLY. DESIGN FEATURES, SPECIFICATIONS AND PERFORMANCE DATA SHOWN HEREON ARE THE PROPERTY OF THE AMPHENOL CORPORATION. NO RIGHTS OF REPRODUCTION ARE IMPLIED. ALL DIMENSIONS ARE SUBJECT TO NORMAL MANUFACTURING VARIATIONS.	
NEXT ASSY:			

Sine Systems - www.amphenol-sine.com 44724 Morley Drive Clinton Township, MI 48036	
2POS, RECEPTACLE, SOCKET, SIZE 18, NORMAL SEAL, BRA, C030, DURAMATE AHDP	
SIZE	REVISION
B C-	A1
DWG NO:	AHDP04-18-06SN-BRAC030
SCALE:	NONE
SHEET	1 OF 1

TITLE: 2POS, RECEPTACLE SOCKET, SIZE 18, NORMAL SEAL, BRA, C030, DURAMATE AHDP

DWG NO: AHDP04-18-06SN-BRAC030

REV: A1

SH: 1

OF: 1

A Series™ - Contact Size 4 Options (Works with: ATHD and DuraMate Series)

Machined Contacts, Pins and Sockets					
Part Number	Description	Size	AWG	Type	Amps
AT60-203-04141-4	Male Contact - Pin, Copper Alloy, Nickel-Plated	4	4	Machined	100A
AT60-204-0490	Male Contact - Pin, Copper Alloy, Nickel-Plated	4	6	Machined	100A
AT62-203-04141-4	Female Contact - Socket, Copper Alloy, Nickel-Plated	4	4	Machined	100A
AT62-203-04141	Female Contact - Socket, Copper Alloy, Nickel-Plated	4	6	Machined	100A

Tooling - Machined Contacts	
Part Number	Description
WA23	Heavy Duty Pneumatic Crimp Tool -Uses Universal Positioner Part No. WA23-101DA and Crimp Locator MFX-3961
WA23-138DA	Die Assembly -for Heavy Duty Pneumatic Crimp Tool, Size 4
WA23-11	Contact Locator, Size 4
96-978-22	Crimper and Dies -for Size 10mm ² -185mm ² Wires
AT11-027-0405	Contact Removal Tool, Plastic, Size 4, 4AWG