

REVISIONS					
REV	ECO	DESCRIPTION	DATE	BY	APPR
A1	-	TECHNICAL DATA SHEET RELEASE	12-MAY-14	KMM	RFC

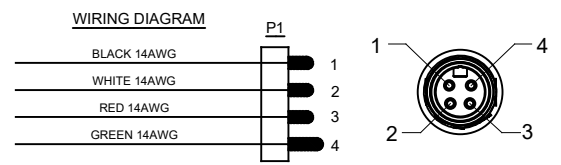
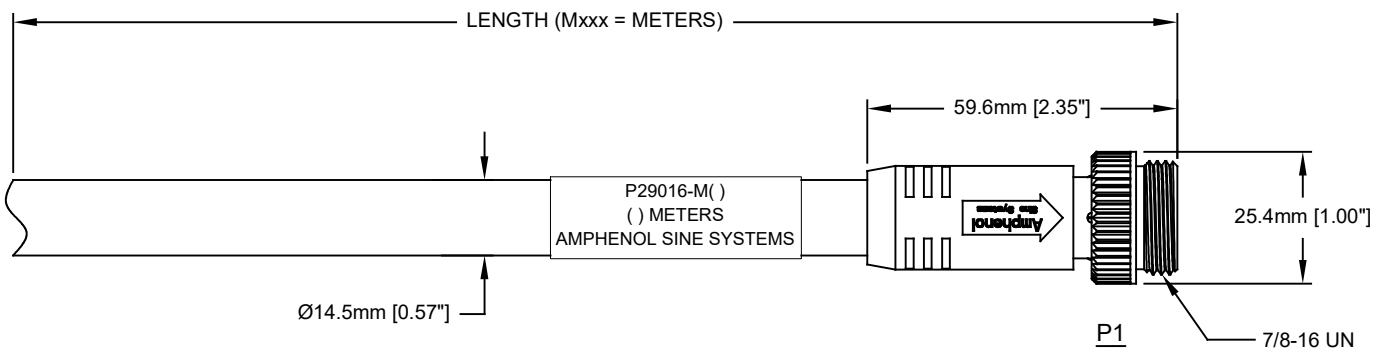

**TECHNICAL DATA:**

- 1) MATERIALS:  
 COUPLING NUT: MACHINED ALUMINUM, ANODIZED  
 INSULATION INSERT: THERMOPLASTIC, UL 94/V-0  
 CONTACT: GOLD FLASH PLATING OVER COPPER ALLOY  
 OVERMOLD MATERIAL: THERMOPLASTIC COLOR: BLACK  
 CABLE RATING: UL LISTED DUAL RATED TC-ER/STOOW, CSA TYPE STOOW, FT4 FLAME RATING, 600V, 90°C DRY & 75°C WET (TC-ER), 105°C (STOOW)  
 CABLE JACKET MATERIAL: PVC COLOR: BLACK  
 CONDUCTOR INSULATION: PVC  
 NUMBER OF CONDUCTORS: (4) 14AWG

- 2) ELECTRICAL DATA:  
 CURRENT (MAX): 15A  
 VOLTAGE (MAX): 600V AC/DC  
 INSULATION RESISTANCE (MIN): 5000M OHMS  
 DIELECTRIC TEST VOLTAGE: 2200V

- 3) MECHANICAL DATA:  
 TEMPERATURE RANGE: -40°C TO 90°C  
 PROTECTION: IP67 (MATED CONDITION)  
 MATING CYCLES: >500  
 VIBRATION RESISTANCE PER MIL-STD-202 METHOD 204  
 THERMAL SHOCK PER MIL-STD-202 METHOD 207  
 48 HOUR SALT SPRAY PER MIL-STD-202 METHOD 101

- 4) RoHS COMPLIANT  
 5) UL 2237 LISTED ASSEMBLY  
 UL FILE NUMBERS: E339703

TOLERANCE	
0-2.99 M = +100.0/-25.0mm	0-9.99 FT = +4" / -1"
3-8.99 M = +150.0/-25.0mm	10.00-29.99 FT = +6" / -1"
9-14.99 M = +300.0/-25.0mm	30.00-49.99 FT = +12" / -1"
15-OVER M = +450.0/-25.0mm	50 FT-OVER = +18" / -1"

QUANTITY	PART NUMBER	DESCRIPTION	ITEM
<b>MATERIALS LIST</b>			
UNLESS OTHERWISE SPECIFIED		SIGNATURES	DATE
1) All dimensions are in metric (mm).		DRAWN: KMM	12-MAY-14
2) Tolerances are as follows:		CHECKED: MRF	12-MAY-14
1 PL DEC ±0.30   Fractions ±1/64		ENGINEER: KMM	
2 PL DEC ±0.15   Angles ±1°		APPROVAL: RFC	12-MAY-14
3) Note reference =		CUSTOMER:	
MATERIAL SPECIFICATIONS:		THIS DRAWING IS SUPPLIED FOR INFORMATION ONLY. DESIGN FEATURES, SPECIFICATIONS AND PERFORMANCE DATA SHOWN HEREON ARE THE PROPERTY OF THE AMPHENOL CORPORATION. NO RIGHTS OF REPRODUCTION ARE IMPLIED. ALL DIMENSIONS ARE SUBJECT TO NORMAL MANUFACTURING VARIATIONS.	
PROCESS SPECIFICATIONS:		SIZE	TYPE
NEXT ASSY:		C-	P29016-Mxxx
		DWG NO:	REVISION
			A1
		SCALE	FULL
			C-P29016
		SHEET	1 OF 1

TTT#422 PB LITE, 4 PIN, M/F, 14AWG, TC-ER/STOOW, PVC dwg no: C-P29008-Mxxx rev: A1 sh: 1 of: 1