

- 1
- 2
- 3
- 4
- 5
- 6
- 7
- 8
- 9
- 10
- 11
- 12
- 13
- 14
- 15
- 16
- 17
- 18
- 19

**LEVER BODY**

Glass-fibre reinforced polyamide based (PA) technopolymer, in Elecolors colours, matte finish.

**PUSH BUTTON**

Technopolymer in Elecolors colours, glossy finish.

**STANDARD EXECUTIONS**

Glass-fibre reinforced technopolymer clamping element with retaining pin, black colour, with knurling on the protruding part to make initial tightening easier. AISI 302 stainless steel return spring.

- **ERX-B:** brass boss, threaded blind hole.
- **ERX-SST:** AISI 303 stainless steel boss, threaded blind hole.
- **ERX-p:** zinc-plated steel threaded stud, chamfered flat end UNI 947 : ISO 4753 (see Technical data on page A-11).
- **ERX-SST-p:** AISI 303 stainless steel threaded stud, chamfered flat end UNI 947 : ISO 4753 (see Technical data on page A-11).

**FEATURES AND APPLICATIONS**

Particularly suitable when the lever turning angle is limited owing to lack of space.

Compared to other types of adjustable handles with metal retaining screw this solution offers:

- absolute electric insulation for the operator
- no visible steel parts subject to rust
- more comfortable lever release.

**STRESS RESISTANCE**

Adjustable handles are generally used for repetitive clamping operations sometimes with very high-frequency.

Therefore, the stress resistance (i.e. the resistance to repeated tightening cycles) of the handle unit is particularly important and, especially, the strength of the toothed element which transmits the tightening force from the handle to the threaded element (boss or stud).

In fact, the results of several laboratory tests, performed with a special instrument that simulates the most severe use conditions, have shown that e.g. ERX.78 adjustable handle can withstand without yielding more than 100,000 tightening cycles, under the action of a force of 490 N (see graphic).

The special glass-fibre reinforced technopolymer enables the ELESAs adjustable handles to guarantee stress resistance values which are much higher than the ones generated under normal working conditions.

**INSTRUCTIONS OF USE**

For clamping, lift the lever to disengage the clamping device teeth and bring it back to start position. By releasing the lever, the return spring automatically engages the teeth.



**ERGOSTYLE®** ELESA Original design stuttgart

NUMBER OF TIGHTENINGS

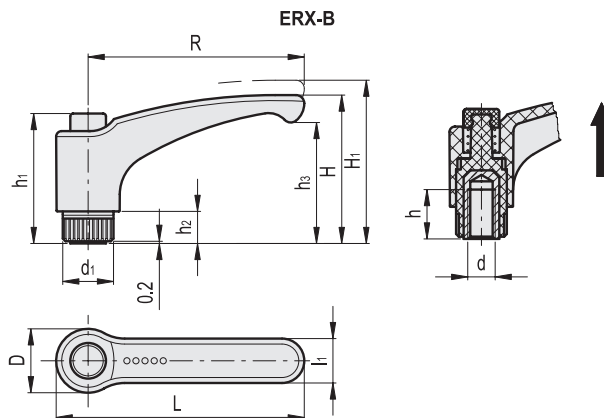
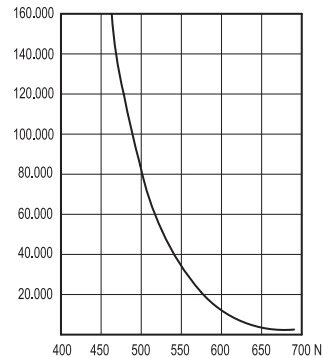

Conversion Table	
1 mm = 0.039 inch	
R	
mm	inch
30	1.18
44	1.73
63	2.48
78	3.07
95	3.74
108	4.25



\* Complete with colour index, example: 233061-C2 ERX.30 B-M3-C2

C1 RAL7021
  C2 RAL2004
  C3 RAL7035
  C4 RAL1021
  C5 RAL5024
  C6 RAL3000
  C17 RAL6017

ERX-B

METRIC

Code	Description	R	d6H	L	D	H	H1	h	h1	h2	h3	d1	l1	Teeth no.	⚖
233061-*	ERX.30 B-M3-*	30	M3	37.5	15	30	33.5	6	29.5	6	23	12	9	18	8
233066-*	ERX.30 B-M4-*	30	M4	37.5	15	30	33.5	10	29.5	6	23	12	9	18	8
233071-*	ERX.30 B-M5-*	30	M5	37.5	15	30	33.5	10	29.5	6	23	12	9	18	7
233076-*	ERX.30 B-M6-*	30	M6	37.5	15	30	33.5	10	29.5	6	23	12	9	18	6
233101-*	ERX.44 B-M5-*	44	M5	52	16	32.5	36	10	29.5	6	25	12	11	18	10
233106-*	ERX.44 B-M6-*	44	M6	52	16	32.5	36	10	29.5	6	25	12	11	18	10
233131-*	ERX.63 B-M6-*	63	M6	72.5	19	43	47	16	37.5	8	34.5	15	13.5	20	21
233136-*	ERX.63 B-M8-*	63	M8	72.5	19	43	47	13	37.5	8	34.5	15	13.5	20	20
233141-*	ERX.63 B-M10-*	63	M10	72.5	19	43	47	13	37.5	8	34.5	15	13.5	20	19
233151-*	ERX.78 B-M8-*	78	M8	89.5	23	54	58	20	47	12	44	19	16	24	46
233156-*	ERX.78 B-M10-*	78	M10	89.5	23	54	58	18	47	12	44	19	16	24	44
233161-*	ERX.78 B-M12-*	78	M12	89.5	23	54	58	17	47	12	44	19	16	24	43
233171-*	ERX.95 B-M10-*	95	M10	108	26	64.5	69	20	54.5	13	53	21.5	18	26	52
233176-*	ERX.95 B-M12-*	95	M12	108	26	64.5	69	20	54.5	13	53	21.5	18	26	51
233181-*	ERX.95 B-M14-*	95	M14	108	26	64.5	69	20	54.5	13	53	21.5	18	26	50
233211-*	ERX.108 B-M12-*	108	M12	123	30	65.5	70	20	54.5	11	52.5	25	20	28	60
233216-*	ERX.108 B-M14-*	108	M14	123	30	65.5	70	20	54.5	11	52.5	25	20	28	59
233221-*	ERX.108 B-M16-*	108	M16	123	30	65.5	70	22	54.5	11	52.5	25	20	28	58



\* Complete with colour index, example: 233061-C2-C1 ERX.30-C2-B-M3-C1

C2 RAL2004
  C3 RAL7035
  C4 RAL1021
  C5 RAL5024
  C6 RAL3000
  C17 RAL6017

ERX-B

METRIC

Code	Description	R	d6H	L	D	H	H1	h	h1	h2	h3	d1	l1	Teeth no.	⚖
233061-*-C1	ERX.30*-B-M3-C1	30	M3	37.5	15	30	33.5	6	29.5	6	23	12	9	18	8
233066-*-C1	ERX.30*-B-M4-C1	30	M4	37.5	15	30	33.5	10	29.5	6	23	12	9	18	8
233071-*-C1	ERX.30*-B-M5-C1	30	M5	37.5	15	30	33.5	10	29.5	6	23	12	9	18	7
233076-*-C1	ERX.30*-B-M6-C1	30	M6	37.5	15	30	33.5	10	29.5	6	23	12	9	18	6
233101-*-C1	ERX.44*-B-M5-C1	44	M5	52	16	32.5	36	10	29.5	6	25	12	11	18	10
233106-*-C1	ERX.44*-B-M6-C1	44	M6	52	16	32.5	36	10	29.5	6	25	12	11	18	10
233131-*-C1	ERX.63*-B-M6-C1	63	M6	72.5	19	43	47	16	37.5	8	34.5	15	13.5	20	21
233136-*-C1	ERX.63*-B-M8-C1	63	M8	72.5	19	43	47	13	37.5	8	34.5	15	13.5	20	20
233141-*-C1	ERX.63*-B-M1-C1	63	M10	72.5	19	43	47	13	37.5	8	34.5	15	13.5	20	19
233151-*-C1	ERX.78*-B-M8-C1	78	M8	89.5	23	54	58	20	47	12	44	19	16	24	46
233156-*-C1	ERX.78*-B-M10-C1	78	M10	89.5	23	54	58	18	47	12	44	19	16	24	44
233161-*-C1	ERX.78*-B-M12-C1	78	M12	89.5	23	54	58	17	47	12	44	19	16	24	43
233171-*-C1	ERX.95*-B-M10-C1	95	M10	108	26	64.5	69	20	54.5	13	53	21.5	18	26	52
233176-*-C1	ERX.95*-B-M12-C1	95	M12	108	26	64.5	69	20	54.5	13	53	21.5	18	26	51
233181-*-C1	ERX.95*-B-M14-C1	95	M14	108	26	64.5	69	20	54.5	13	53	21.5	18	26	50
233211-*-C1	ERX.108*-B-M12-C1	108	M12	123	30	65.5	70	20	54.5	11	52.5	25	20	28	60
233216-*-C1	ERX.108*-B-M14-C1	108	M14	123	30	65.5	70	20	54.5	11	52.5	25	20	28	59
233221-*-C1	ERX.108*-B-M16-C1	108	M16	123	30	65.5	70	22	54.5	11	52.5	25	20	28	58



Clamping handles

- 1
- 2
- 3
- 4
- 5
- 6
- 7
- 8
- 9
- 10
- 11
- 12
- 13
- 14
- 15
- 16
- 17
- 18
- 19
- 20

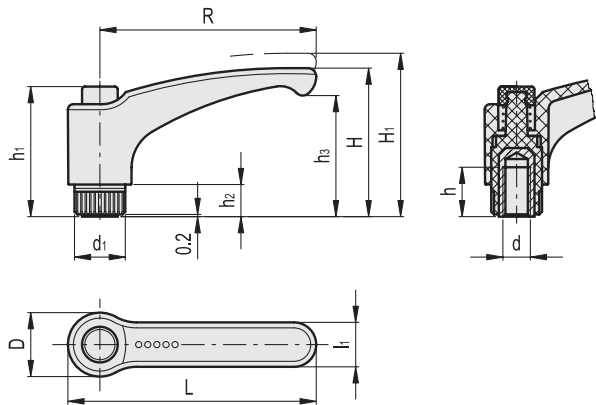

**Conversion Table**  
1 mm = 0,039 inch

mm	inch
30	1.18
44	1.73
63	2.48
78	3.07
95	3.74
108	4.25



\*Complete with colour index, example: 235071-C2 ERX.30 SST-M5-C2

- C1 RAL7021
- C2 RAL2004
- C3 RAL7035
- C4 RAL1021
- C5 RAL5024
- C6 RAL3000
- C17 RAL6017

ERX-SST

**INOX** STAINLESS STEEL **METRIC**

Code	Description	R	d6H	L	D	H	H1	h	h1	h2	h3	d1	l1	Teeth no.	⚖
235069.*	ERX.30 SST-M3.*	30	M3	37.5	15	30	33.5	6	29.5	6	23	12	9	18	8
235070.*	ERX.30 SST-M4.*	30	M4	37.5	15	30	33.5	10	29.5	6	23	12	9	18	8
235071.*	ERX.30 SST-M5.*	30	M5	37.5	15	30	33.5	6	29.5	6	23	12	9	18	8
235076.*	ERX.30 SST-M6.*	30	M6	37.5	15	30	33.5	10	29.5	6	23	12	9	18	6
235101.*	ERX.44 SST-M5.*	44	M5	52	16	32.5	36	6	29.5	6	25	12	11	18	11
235106.*	ERX.44 SST-M6.*	44	M6	52	16	32.5	36	10	29.5	6	25	12	11	18	10
235131.*	ERX.63 SST-M6.*	63	M6	72.5	19	43	47	12	37.5	8	34.5	15	13.5	20	22
235136.*	ERX.63 SST-M8.*	63	M8	72.5	19	43	47	13	37.5	8	34.5	15	13.5	20	20
235151.*	ERX.78 SST-M8.*	78	M8	89.5	23	54	58	13	47	12	44	19	16	24	46
235156.*	ERX.78 SST-M10.*	78	M10	89.5	23	54	58	17	47	12	44	19	16	24	44
235176.*	ERX.95 SST-M12.*	95	M12	108	26	64.5	69	20	54.5	13	53	21.5	18	26	52
235191.*	ERX.108 SST-M12.*	108	M12	123	30	65.5	70	20	54.5	11	52.5	25	20	28	60



\*Complete with colour index, example: 235071-C2-C1 ERX.30-C2-SST-M5-C1

- C2 RAL2004
- C3 RAL7035
- C4 RAL1021
- C5 RAL5024
- C6 RAL3000
- C17 RAL6017

ERX-SST

**INOX** STAINLESS STEEL **METRIC**

Code	Description	R	d6H	L	D	H	H1	h	h1	h2	h3	d1	l1	Teeth no.	⚖
235069.*-C1	ERX.30*-SST-M3-C1	30	M3	37.5	15	30	33.5	6	29.5	6	23	12	9	18	8
235070.*-C1	ERX.30*-SST-M4-C1	30	M4	37.5	15	30	33.5	10	29.5	6	23	12	9	18	8
235071.*-C1	ERX.30*-SST-M5-C1	30	M5	37.5	15	30	33.5	6	29.5	6	23	12	9	18	8
235076.*-C1	ERX.30*-SST-M6-C1	30	M6	37.5	15	30	33.5	10	29.5	6	23	12	9	18	6
235101.*-C1	ERX.44*-SST-M5-C1	44	M5	52	16	32.5	36	6	29.5	6	25	12	11	18	11
235106.*-C1	ERX.44*-SST-M6-C1	44	M6	52	16	32.5	36	10	29.5	6	25	12	11	18	10
235131.*-C1	ERX.63*-SST-M6-C1	63	M6	72.5	19	43	47	12	37.5	8	34.5	15	13.5	20	22
235136.*-C1	ERX.63*-SST-M8-C1	63	M8	72.5	19	43	47	13	37.5	8	34.5	15	13.5	20	20
235151.*-C1	ERX.78*-SST-M8-C1	78	M8	89.5	23	54	58	13	47	12	44	19	16	24	46
235156.*-C1	ERX.78*-SST-M10-C1	78	M10	89.5	23	54	58	17	47	12	44	19	16	24	44
235176.*-C1	ERX.95*-SST-M12-C1	95	M12	108	26	64.5	69	20	54.5	13	53	21.5	18	26	52
235191.*-C1	ERX.108*-SST-M12-C1	108	M12	123	30	65.5	70	20	54.5	11	52.5	25	20	28	60

Clamping handles

Conversion Table 1 mm = 0.039 inch	
R	
mm	inch
30	1.18
44	1.73
63	2.48
78	3.07
95	3.74
108	4.25

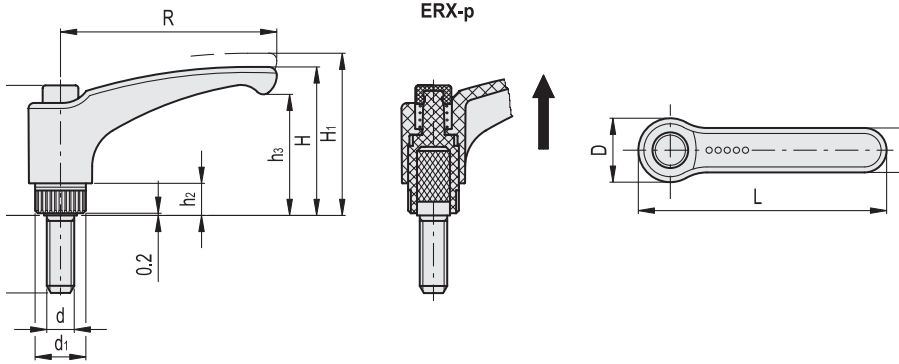

\* Complete with colour index, example: 234001-C2 ERX.30 p-M5x10-C2

- C1  
RAL7021
- C2  
RAL2004
- C3  
RAL7035
- C4  
RAL1021
- C5  
RAL5024
- C6  
RAL3000
- C17  
RAL6017

ERX-p

Code	Description	R	d6g	L	D	H	H1	h1	h2	h3	d1	l	l1	Teeth no.	Δ	Δ
234001-*	ERX.30 p-M5x10-*	30	M5	37.5	15	30	33.5	29.5	6	23	12	10	9	18	6	
234006-*	ERX.30 p-M5x16-*	30	M5	37.5	15	30	33.5	29.5	6	23	12	16	9	18	6	
234011-*	ERX.30 p-M5x20-*	30	M5	37.5	15	30	33.5	29.5	6	23	12	20	9	18	7	
234016-*	ERX.30 p-M6x10-*	30	M6	37.5	15	30	33.5	29.5	6	23	12	10	9	18	8	
234021-*	ERX.30 p-M6x16-*	30	M6	37.5	15	30	33.5	29.5	6	23	12	16	9	18	9	
234026-*	ERX.30 p-M6x20-*	30	M6	37.5	15	30	33.5	29.5	6	23	12	20	9	18	10	
234031-*	ERX.30 p-M6x25-*	30	M6	37.5	15	30	33.5	29.5	6	23	12	25	9	18	11	
234036-*	ERX.30 p-M6x30-*	30	M6	37.5	15	30	33.5	29.5	6	23	12	30	9	18	12	
234046-*	ERX.30 p-M6x40-*	30	M6	37.5	15	30	33.5	29.5	6	23	12	40	9	18	14	
234101-*	ERX.44 p-M5x10-*	44	M5	52	16	32.5	36	29.5	6	25	12	10	11	18	11	
234106-*	ERX.44 p-M5x16-*	44	M5	52	16	32.5	36	29.5	6	25	12	16	11	18	12	
234111-*	ERX.44 p-M5x20-*	44	M5	52	16	32.5	36	29.5	6	25	12	20	11	18	13	
234116-*	ERX.44 p-M6x10-*	44	M6	52	16	32.5	36	29.5	6	25	12	10	11	18	13	
234121-*	ERX.44 p-M6x16-*	44	M6	52	16	32.5	36	29.5	6	25	12	16	11	18	14	
234126-*	ERX.44 p-M6x20-*	44	M6	52	16	32.5	36	29.5	6	25	12	20	11	18	15	
234131-*	ERX.44 p-M6x25-*	44	M6	52	16	32.5	36	29.5	6	25	12	25	11	18	16	
234136-*	ERX.44 p-M6x30-*	44	M6	52	16	32.5	36	29.5	6	25	12	30	11	18	17	
234141-*	ERX.44 p-M6x35-*	44	M6	52	16	32.5	36	29.5	6	25	12	35	11	18	18	
234146-*	ERX.44 p-M6x40-*	44	M6	52	16	32.5	36	29.5	6	25	12	40	11	18	19	
234151-*	ERX.44 p-M6x45-*	44	M6	52	16	32.5	36	29.5	6	25	12	45	11	18	20	
234159-*	ERX.44 p-M8x16-*	44	M8	52	16	32.5	36	29.5	6	25	12	16	11	18	17	
234161-*	ERX.44 p-M8x20-*	44	M8	52	16	32.5	36	29.5	6	25	12	20	11	18	18	
234163-*	ERX.44 p-M8x25-*	44	M8	52	16	32.5	36	29.5	6	25	12	25	11	18	19	
234301-*	ERX.63 p-M6x10-*	63	M6	72.5	19	43	47	37.5	8	34.5	15	10	13.5	20	28	
234306-*	ERX.63 p-M6x16-*	63	M6	72.5	19	43	47	37.5	8	34.5	15	16	13.5	20	29	
234311-*	ERX.63 p-M6x20-*	63	M6	72.5	19	43	47	37.5	8	34.5	15	20	13.5	20	30	
234316-*	ERX.63 p-M6x25-*	63	M6	72.5	19	43	47	37.5	8	34.5	15	25	13.5	20	31	
234321-*	ERX.63 p-M6x30-*	63	M6	72.5	19	43	47	37.5	8	34.5	15	30	13.5	20	32	
234323-*	ERX.63 p-M6x35-*	63	M6	72.5	19	43	47	37.5	8	34.5	15	35	13.5	20	32	
234326-*	ERX.63 p-M6x40-*	63	M6	72.5	19	43	47	37.5	8	34.5	15	40	13.5	20	32	
234329-*	ERX.63 p-M6x50-*	63	M6	72.5	19	43	47	37.5	8	34.5	15	50	13.5	20	32	
234333-*	ERX.63 p-M8x16-*	63	M8	72.5	19	43	47	37.5	8	34.5	15	16	13.5	20	32	
234336-*	ERX.63 p-M8x20-*	63	M8	72.5	19	43	47	37.5	8	34.5	15	20	13.5	20	32	
234341-*	ERX.63 p-M8x25-*	63	M8	72.5	19	43	47	37.5	8	34.5	15	25	13.5	20	34	
234346-*	ERX.63 p-M8x30-*	63	M8	72.5	19	43	47	37.5	8	34.5	15	30	13.5	20	36	
234351-*	ERX.63 p-M8x35-*	63	M8	72.5	19	43	47	37.5	8	34.5	15	35	13.5	20	38	
234356-*	ERX.63 p-M8x40-*	63	M8	72.5	19	43	47	37.5	8	34.5	15	40	13.5	20	40	
234361-*	ERX.63 p-M8x45-*	63	M8	72.5	19	43	47	37.5	8	34.5	15	45	13.5	20	41	
234366-*	ERX.63 p-M8x50-*	63	M8	72.5	19	43	47	37.5	8	34.5	15	50	13.5	20	43	
234371-*	ERX.63 p-M8x60-*	63	M8	72.5	19	43	47	37.5	8	34.5	15	60	13.5	20	46	
234376-*	ERX.63 p-M8x70-*	63	M8	72.5	19	43	47	37.5	8	34.5	15	70	13.5	20	50	
234378-*	ERX.63 p-M8x80-*	63	M8	72.5	19	43	47	37.5	8	34.5	15	80	13.5	20	50	
234381-*	ERX.63 p-M10x20-*	63	M10	72.5	19	43	47	37.5	8	34.5	15	20	13.5	20	40	
234382-*	ERX.63 p-M10x30-*	63	M10	72.5	19	43	47	37.5	8	34.5	15	30	13.5	20	43	
234383-*	ERX.63 p-M10x40-*	63	M10	72.5	19	43	47	37.5	8	34.5	15	40	13.5	20	46	
234385-*	ERX.63 p-M10x50-*	63	M10	72.5	19	43	47	37.5	8	34.5	15	50	13.5	20	50	
234387-*	ERX.63 p-M10x60-*	63	M10	72.5	19	43	47	37.5	8	34.5	15	60	13.5	20	54	

METRIC



Clamping handles

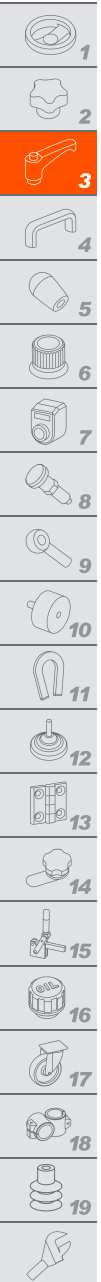

Conversion Table	
1 mm = 0.039 inch	
R	
mm	inch
30	1.18
44	1.73
63	2.48
78	3.07
95	3.74
108	4.25



\* Complete with colour index, example: 234498-C2 ERX.78 p-M8x20-C2

C1 RAL7021  
 C2 RAL2004  
 C3 RAL7035  
 C4 RAL1021  
 C5 RAL5024  
 C6 RAL3000  
 C17 RAL6017

**METRIC**

ERX-p

Code	Description	R	d6g	L	D	H	H1	h1	h2	h3	d1	l	l1	Teeth no.	
234498*	ERX.78 p-M8x20-*	78	M8	89.5	23	54	58	47	12	44	19	20	16	24	42
234501*	ERX.78 p-M8x25-*	78	M8	89.5	23	54	58	47	12	44	19	25	16	24	43
234503*	ERX.78 p-M8x30-*	78	M8	89.5	23	54	58	47	12	44	19	30	16	24	44
234506*	ERX.78 p-M8x40-*	78	M8	89.5	23	54	58	47	12	44	19	40	16	24	48
234507*	ERX.78 p-M8x45-*	78	M8	89.5	23	54	58	47	12	44	19	45	16	24	50
234509*	ERX.78 p-M8x50-*	78	M8	89.5	23	54	58	47	12	44	19	50	16	24	52
234511*	ERX.78 p-M8x55-*	78	M8	89.5	23	54	58	47	12	44	19	55	16	24	55
234513*	ERX.78 p-M8x60-*	78	M8	89.5	23	54	58	47	12	44	19	60	16	24	57
234515*	ERX.78 p-M8x70-*	78	M8	89.5	23	54	58	47	12	44	19	70	16	24	60
234516*	ERX.78 p-M10x20-*	78	M10	89.5	23	54	58	47	12	44	19	20	16	24	58
234521*	ERX.78 p-M10x25-*	78	M10	89.5	23	54	58	47	12	44	19	25	16	24	61
234526*	ERX.78 p-M10x30-*	78	M10	89.5	23	54	58	47	12	44	19	30	16	24	64
234531*	ERX.78 p-M10x35-*	78	M10	89.5	23	54	58	47	12	44	19	35	16	24	67
234536*	ERX.78 p-M10x40-*	78	M10	89.5	23	54	58	47	12	44	19	40	16	24	70
234541*	ERX.78 p-M10x50-*	78	M10	89.5	23	54	58	47	12	44	19	50	16	24	76
234546*	ERX.78 p-M10x60-*	78	M10	89.5	23	54	58	47	12	44	19	60	16	24	82
234551*	ERX.78 p-M10x70-*	78	M10	89.5	23	54	58	47	12	44	19	70	16	24	88
234561*	ERX.78 p-M12x20-*	78	M12	89.5	23	54	58	47	12	44	19	20	16	24	70
234566*	ERX.78 p-M12x25-*	78	M12	89.5	23	54	58	47	12	44	19	25	16	24	71
234571*	ERX.78 p-M12x30-*	78	M12	89.5	23	54	58	47	12	44	19	30	16	24	74
234573*	ERX.78 p-M12x35-*	78	M12	89.5	23	54	58	47	12	44	19	35	16	24	75
234576*	ERX.78 p-M12x40-*	78	M12	89.5	23	54	58	47	12	44	19	40	16	24	76
234581*	ERX.78 p-M12x45-*	78	M12	89.5	23	54	58	47	12	44	19	45	16	24	77
234586*	ERX.78 p-M12x50-*	78	M12	89.5	23	54	58	47	12	44	19	50	16	24	78
234591*	ERX.78 p-M12x60-*	78	M12	89.5	23	54	58	47	12	44	19	60	16	24	81
234593*	ERX.78 p-M12x70-*	78	M12	89.5	23	54	58	47	12	44	19	70	16	24	84
234596*	ERX.78 p-M12x80-*	78	M12	89.5	23	54	58	47	12	44	19	80	16	24	86
234716*	ERX.95 p-M12x20-*	95	M12	108	26	64.5	69	54.5	13	53	21.5	20	18	26	86
234726*	ERX.95 p-M12x30-*	95	M12	108	26	64.5	69	54.5	13	53	21.5	30	18	26	86
234741*	ERX.95 p-M12x50-*	95	M12	108	26	64.5	69	54.5	13	53	21.5	50	18	26	90
234751*	ERX.95 p-M12x70-*	95	M12	108	26	64.5	69	54.5	13	53	21.5	70	18	26	94
234901*	ERX.95 p-M16x30-*	95	M16	108	26	64.5	69	54.5	13	53	21.5	30	18	26	104
234911*	ERX.95 p-M16x50-*	95	M16	108	26	64.5	69	54.5	13	53	21.5	50	18	26	110
234921*	ERX.95 p-M16x70-*	95	M16	108	26	64.5	69	54.5	13	53	21.5	70	18	26	116
234996*	ERX.108 p-M12x20-*	108	M12	123	30	65.5	70	54.5	11	52.5	25	20	20	28	70
235001*	ERX.108 p-M12x30-*	108	M12	123	30	65.5	70	54.5	11	52.5	25	30	20	28	70
235006*	ERX.108 p-M12x50-*	108	M12	123	30	65.5	70	54.5	11	52.5	25	50	20	28	75
235011*	ERX.108 p-M12x70-*	108	M12	123	30	65.5	70	54.5	11	52.5	25	70	20	28	80
235016*	ERX.108 p-M14x30-*	108	M14	123	30	65.5	70	54.5	11	52.5	25	30	20	28	86
235021*	ERX.108 p-M14x50-*	108	M14	123	30	65.5	70	54.5	11	52.5	25	50	20	28	90
235026*	ERX.108 p-M14x70-*	108	M14	123	30	65.5	70	54.5	11	52.5	25	70	20	28	95
235036*	ERX.108 p-M16x30-*	108	M16	123	30	65.5	70	54.5	11	52.5	25	30	20	28	100
235041*	ERX.108 p-M16x50-*	108	M16	123	30	65.5	70	54.5	11	52.5	25	50	20	28	105
235046*	ERX.108 p-M16x70-*	108	M16	123	30	65.5	70	54.5	11	52.5	25	70	20	28	110

Clamping handles

Conversion Table	
1 mm = 0.039 inch	
R	
mm	inch
30	1.18
44	1.73
63	2.48
78	3.07
95	3.74
108	4.25

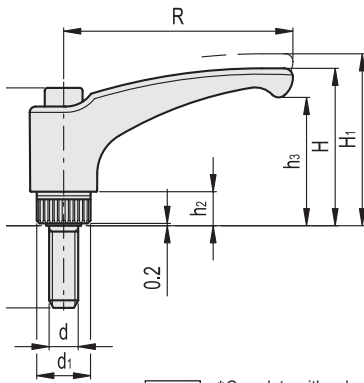

ERX-p

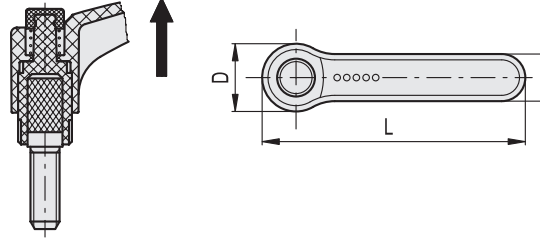

\* Complete with colour index, example: 234001-C2-C1 ERX.30-C2-p-M5x10-C1

**C2** RAL2004

**C3** RAL7035

**C4** RAL1021

**C5** RAL5024

**C6** RAL3000

**C17** RAL6017

**METRIC**

ERX-p

Code	Description	R	d6g	L	D	H	H1	h1	h2	h3	d1	l	l1	Teeth no.	⚖
234001*-C1	ERX.30*-p-M5x10-C1	30	M5	37.5	15	30	33.5	29.5	6	23	12	10	9	18	6
234006*-C1	ERX.30*-p-M5x16-C1	30	M5	37.5	15	30	33.5	29.5	6	23	12	16	9	18	6
234011*-C1	ERX.30*-p-M5x20-C1	30	M5	37.5	15	30	33.5	29.5	6	23	12	20	9	18	7
234016*-C1	ERX.30*-p-M6x10-C1	30	M6	37.5	15	30	33.5	29.5	6	23	12	10	9	18	8
234021*-C1	ERX.30*-p-M6x16-C1	30	M6	37.5	15	30	33.5	29.5	6	23	12	16	9	18	9
234026*-C1	ERX.30*-p-M6x20-C1	30	M6	37.5	15	30	33.5	29.5	6	23	12	20	9	18	10
234031*-C1	ERX.30*-p-M6x25-C1	30	M6	37.5	15	30	33.5	29.5	6	23	12	25	9	18	11
234036*-C1	ERX.30*-p-M6x30-C1	30	M6	37.5	15	30	33.5	29.5	6	23	12	30	9	18	12
234046*-C1	ERX.30*-p-M6x40-C1	30	M6	37.5	15	30	33.5	29.5	6	23	12	40	9	18	14
234101*-C1	ERX.44*-p-M5x10-C1	44	M5	52	16	32.5	36	29.5	6	25	12	10	11	18	11
234106*-C1	ERX.44*-p-M5x16-C1	44	M5	52	16	32.5	36	29.5	6	25	12	16	11	18	12
234111*-C1	ERX.44*-p-M5x20-C1	44	M5	52	16	32.5	36	29.5	6	25	12	20	11	18	13
234116*-C1	ERX.44*-p-M6x10-C1	44	M6	52	16	32.5	36	29.5	6	25	12	10	11	18	13
234121*-C1	ERX.44*-p-M6x16-C1	44	M6	52	16	32.5	36	29.5	6	25	12	16	11	18	14
234126*-C1	ERX.44*-p-M6x20-C1	44	M6	52	16	32.5	36	29.5	6	25	12	20	11	18	15
234131*-C1	ERX.44*-p-M6x25-C1	44	M6	52	16	32.5	36	29.5	6	25	12	25	11	18	16
234136*-C1	ERX.44*-p-M6x30-C1	44	M6	52	16	32.5	36	29.5	6	25	12	30	11	18	17
234141*-C1	ERX.44*-p-M6x35-C1	44	M6	52	16	32.5	36	29.5	6	25	12	35	11	18	18
234146*-C1	ERX.44*-p-M6x40-C1	44	M6	52	16	32.5	36	29.5	6	25	12	40	11	18	19
234151*-C1	ERX.44*-p-M6x45-C1	44	M6	52	16	32.5	36	29.5	6	25	12	45	11	18	20
234159*-C1	ERX.44*-p-M8x16-C1	44	M8	52	16	32.5	36	29.5	6	25	12	16	11	18	17
234161*-C1	ERX.44*-p-M8x20-C1	44	M8	52	16	32.5	36	29.5	6	25	12	20	11	18	18
234163*-C1	ERX.44*-p-M8x25-C1	44	M8	52	16	32.5	36	29.5	6	25	12	25	11	18	19
234301*-C1	ERX.63*-p-M6x10-C1	63	M6	72.5	19	43	47	37.5	8	34.5	15	10	13.5	20	28
234306*-C1	ERX.63*-p-M6x16-C1	63	M6	72.5	19	43	47	37.5	8	34.5	15	16	13.5	20	29
234311*-C1	ERX.63*-p-M6x20-C1	63	M6	72.5	19	43	47	37.5	8	34.5	15	20	13.5	20	30
234316*-C1	ERX.63*-p-M6x25-C1	63	M6	72.5	19	43	47	37.5	8	34.5	15	25	13.5	20	31
234321*-C1	ERX.63*-p-M6x30-C1	63	M6	72.5	19	43	47	37.5	8	34.5	15	30	13.5	20	32
234323*-C1	ERX.63*-p-M6x35-C1	63	M6	72.5	19	43	47	37.5	8	34.5	15	35	13.5	20	32
234326*-C1	ERX.63*-p-M6x40-C1	63	M6	72.5	19	43	47	37.5	8	34.5	15	40	13.5	20	32
234329*-C1	ERX.63*-p-M6x50-C1	63	M6	72.5	19	43	47	37.5	8	34.5	15	50	13.5	20	32
234333*-C1	ERX.63*-p-M8x16-C1	63	M8	72.5	19	43	47	37.5	8	34.5	15	16	13.5	20	32
234336*-C1	ERX.63*-p-M8x20-C1	63	M8	72.5	19	43	47	37.5	8	34.5	15	20	13.5	20	32
234341*-C1	ERX.63*-p-M8x25-C1	63	M8	72.5	19	43	47	37.5	8	34.5	15	25	13.5	20	34
234346*-C1	ERX.63*-p-M8x30-C1	63	M8	72.5	19	43	47	37.5	8	34.5	15	30	13.5	20	36
234351*-C1	ERX.63*-p-M8x35-C1	63	M8	72.5	19	43	47	37.5	8	34.5	15	35	13.5	20	38
234356*-C1	ERX.63*-p-M8x40-C1	63	M8	72.5	19	43	47	37.5	8	34.5	15	40	13.5	20	40
234361*-C1	ERX.63*-p-M8x45-C1	63	M8	72.5	19	43	47	37.5	8	34.5	15	45	13.5	20	41
234366*-C1	ERX.63*-p-M8x50-C1	63	M8	72.5	19	43	47	37.5	8	34.5	15	50	13.5	20	43
234371*-C1	ERX.63*-p-M8x60-C1	63	M8	72.5	19	43	47	37.5	8	34.5	15	60	13.5	20	46
234376*-C1	ERX.63*-p-M8x70-C1	63	M8	72.5	19	43	47	37.5	8	34.5	15	70	13.5	20	50
234378*-C1	ERX.63*-p-M8x80-C1	63	M8	72.5	19	43	47	37.5	8	34.5	15	80	13.5	20	50
234381*-C1	ERX.63*-p-M10x2-C1	63	M10	72.5	19	43	47	37.5	8	34.5	15	20	13.5	20	40
234382*-C1	ERX.63*-p-M10x3-C1	63	M10	72.5	19	43	47	37.5	8	34.5	15	30	13.5	20	43
234383*-C1	ERX.63*-p-M10x4-C1	63	M10	72.5	19	43	47	37.5	8	34.5	15	40	13.5	20	46
234385*-C1	ERX.63*-p-M10x5-C1	63	M10	72.5	19	43	47	37.5	8	34.5	15	50	13.5	20	50
234387*-C1	ERX.63*-p-M10x6-C1	63	M10	72.5	19	43	47	37.5	8	34.5	15	60	13.5	20	54



Clamping handles

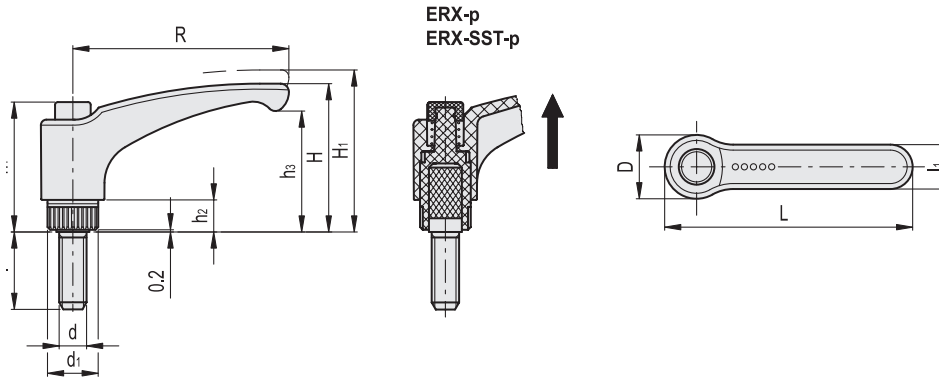
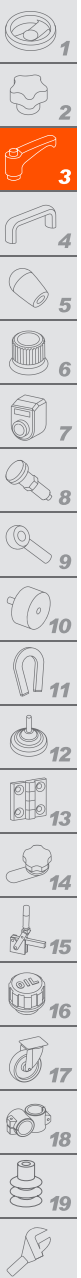

**Conversion Table**  
1 mm = 0.039 inch

mm	inch
30	1.18
44	1.73
63	2.48
78	3.07
95	3.74
108	4.25

\*Complete with colour index, example: 234498-C2-C1 ERX.78-C2-p-M8x20-C1

	<b>C2</b>		<b>C3</b>		<b>C4</b>		<b>C5</b>		<b>C6</b>		<b>C17</b>
	RAL2004		RAL7035		RAL1021		RAL5024		RAL3000		RAL6017

**METRIC**

**ERX-p**

Code	Description	R	d6g	L	D	H	H1	h1	h2	h3	d1	l	l1	Teeth no.	⚙️
234498*-C1	ERX.78*-p-M8x20-C1	78	M8	89.5	23	54	58	47	12	44	19	20	16	24	42
234501*-C1	ERX.78*-p-M8x25-C1	78	M8	89.5	23	54	58	47	12	44	19	25	16	24	43
234503*-C1	ERX.78*-p-M8x30-C1	78	M8	89.5	23	54	58	47	12	44	19	30	16	24	44
234506*-C1	ERX.78*-p-M8x40-C1	78	M8	89.5	23	54	58	47	12	44	19	40	16	24	48
234507*-C1	ERX.78*-p-M8x45-C1	78	M8	89.5	23	54	58	47	12	44	19	45	16	24	50
234509*-C1	ERX.78*-p-M8x50-C1	78	M8	89.5	23	54	58	47	12	44	19	50	16	24	52
234511*-C1	ERX.78*-p-M8x55-C1	78	M8	89.5	23	54	58	47	12	44	19	55	16	24	55
234513*-C1	ERX.78*-p-M8x60-C1	78	M8	89.5	23	54	58	47	12	44	19	60	16	24	57
234515*-C1	ERX.78*-p-M8x70-C1	78	M8	89.5	23	54	58	47	12	44	19	70	16	24	60
234516*-C1	ERX.78*-p-M10x20-C1	78	M10	89.5	23	54	58	47	12	44	19	20	16	24	58
234521*-C1	ERX.78*-p-M10x25-C1	78	M10	89.5	23	54	58	47	12	44	19	25	16	24	61
234526*-C1	ERX.78*-p-M10x30-C1	78	M10	89.5	23	54	58	47	12	44	19	30	16	24	64
234531*-C1	ERX.78*-p-M10x35-C1	78	M10	89.5	23	54	58	47	12	44	19	35	16	24	67
234536*-C1	ERX.78*-p-M10x40-C1	78	M10	89.5	23	54	58	47	12	44	19	40	16	24	70
234541*-C1	ERX.78*-p-M10x50-C1	78	M10	89.5	23	54	58	47	12	44	19	50	16	24	76
234546*-C1	ERX.78*-p-M10x60-C1	78	M10	89.5	23	54	58	47	12	44	19	60	16	24	82
234551*-C1	ERX.78*-p-M10x70-C1	78	M10	89.5	23	54	58	47	12	44	19	70	16	24	88
234561*-C1	ERX.78*-p-M12x20-C1	78	M12	89.5	23	54	58	47	12	44	19	20	16	24	70
234566*-C1	ERX.78*-p-M12x25-C1	78	M12	89.5	23	54	58	47	12	44	19	25	16	24	71
234571*-C1	ERX.78*-p-M12x30-C1	78	M12	89.5	23	54	58	47	12	44	19	30	16	24	74
234573*-C1	ERX.78*-p-M12x35-C1	78	M12	89.5	23	54	58	47	12	44	19	35	16	24	75
234576*-C1	ERX.78*-p-M12x40-C1	78	M12	89.5	23	54	58	47	12	44	19	40	16	24	76
234581*-C1	ERX.78*-p-M12x45-C1	78	M12	89.5	23	54	58	47	12	44	19	45	16	24	77
234586*-C1	ERX.78*-p-M12x50-C1	78	M12	89.5	23	54	58	47	12	44	19	50	16	24	78
234591*-C1	ERX.78*-p-M12x60-C1	78	M12	89.5	23	54	58	47	12	44	19	60	16	24	81
234593*-C1	ERX.78*-p-M12x70-C1	78	M12	89.5	23	54	58	47	12	44	19	70	16	24	84
234596*-C1	ERX.78*-p-M12x80-C1	78	M12	89.5	23	54	58	47	12	44	19	80	16	24	86
234716*-C1	ERX.95*-p-M12x20-C1	95	M12	108	26	64.5	69	54.5	13	53	21.5	20	18	26	86
234726*-C1	ERX.95*-p-M12x30-C1	95	M12	108	26	64.5	69	54.5	13	53	21.5	30	18	26	86
234741*-C1	ERX.95*-p-M12x50-C1	95	M12	108	26	64.5	69	54.5	13	53	21.5	50	18	26	90
234751*-C1	ERX.95*-p-M12x70-C1	95	M12	108	26	64.5	69	54.5	13	53	21.5	70	18	26	94
234901*-C1	ERX.95*-p-M16x30-C1	95	M16	108	26	64.5	69	54.5	13	53	21.5	30	18	26	104
234911*-C1	ERX.95*-p-M16x50-C1	95	M16	108	26	64.5	69	54.5	13	53	21.5	50	18	26	110
234921*-C1	ERX.95*-p-M16x70-C1	95	M16	108	26	64.5	69	54.5	13	53	21.5	70	18	26	116
234996*-C1	ERX.108*-p-M12x20-C1	108	M12	123	30	65.5	70	54.5	11	52.5	25	20	20	28	70
235001*-C1	ERX.108*-p-M12x30-C1	108	M12	123	30	65.5	70	54.5	11	52.5	25	30	20	28	70
235006*-C1	ERX.108*-p-M12x50-C1	108	M12	123	30	65.5	70	54.5	11	52.5	25	50	20	28	75
235011*-C1	ERX.108*-p-M12x70-C1	108	M12	123	30	65.5	70	54.5	11	52.5	25	70	20	28	80
235016*-C1	ERX.108*-p-M14x30-C1	108	M14	123	30	65.5	70	54.5	11	52.5	25	30	20	28	86
235021*-C1	ERX.108*-p-M14x50-C1	108	M14	123	30	65.5	70	54.5	11	52.5	25	50	20	28	90
235026*-C1	ERX.108*-p-M14x70-C1	108	M14	123	30	65.5	70	54.5	11	52.5	25	70	20	28	95
235036*-C1	ERX.108*-p-M16x30-C1	108	M16	123	30	65.5	70	54.5	11	52.5	25	30	20	28	100
235041*-C1	ERX.108*-p-M16x50-C1	108	M16	123	30	65.5	70	54.5	11	52.5	25	50	20	28	105
235046*-C1	ERX.108*-p-M16x70-C1	108	M16	123	30	65.5	70	54.5	11	52.5	25	70	20	28	110

Clamping handles



\* Complete with colour index, example: 235061-C2 ERX.30-SST-p M5x10-C2

C1 RAL7021
  C2 RAL2004
  C3 RAL7035
  C4 RAL1021
  C5 RAL5024
  C6 RAL3000
  C17 RAL6017

ERX-SST-p

INOX STAINLESS STEEL METRIC

Code	Description	R	d6g	L	D	H	H1	h1	h2	h3	d1	l	l1	Teeth no.	⚖
235061-*	ERX.30-SST-p M5x10-*	30	M5	37.5	15	30	33.5	29.5	6	23	12	10	9	18	6
235066-*	ERX.30-SST-p M5x16-*	30	M5	37.5	15	30	33.5	29.5	6	23	12	16	9	18	7
235196-*	ERX.30-SST-p M6x10-*	30	M6	37.5	15	30	33.5	29.5	6	23	12	10	9	18	8
235201-*	ERX.30 SST-p-M6x16-*	30	M6	37.5	15	30	33.5	29.5	6	23	12	16	9	18	9
235203-*	ERX.30 SST-p-M6x20-*	30	M6	37.5	15	30	33.5	29.5	6	23	12	20	9	18	10
235205-*	ERX.30 SST-p-M6x25-*	30	M6	37.5	15	30	33.5	29.5	6	23	12	25	9	18	11
235207-*	ERX.30 SST-p-M6x30-*	30	M6	37.5	15	30	33.5	29.5	6	23	12	30	9	18	12
235209-*	ERX.44 SST-p-M5x10-*	44	M5	52	16	32.5	36	29.5	6	25	12	10	11	18	10
235211-*	ERX.44 SST-p-M5x16-*	44	M5	52	16	32.5	36	29.5	6	25	12	16	11	18	12
235216-*	ERX.44 SST-p-M6x10-*	44	M6	52	16	32.5	36	29.5	6	25	12	10	11	18	13
235221-*	ERX.44 SST-p-M6x16-*	44	M6	52	16	32.5	36	29.5	6	25	12	16	11	18	14
235226-*	ERX.44 SST-p-M6x20-*	44	M6	52	16	32.5	36	29.5	6	25	12	20	11	18	16
235231-*	ERX.44 SST-p-M6x25-*	44	M6	52	16	32.5	36	29.5	6	25	12	25	11	18	17
235236-*	ERX.44 SST-p-M6x30-*	44	M6	52	16	32.5	36	29.5	6	25	12	30	11	18	18
235341-*	ERX.63 SST-p-M6x10-*	63	M6	72.5	19	43	47	37.5	8	34.5	15	10	13.5	20	30
235351-*	ERX.63 SST-p-M6x20-*	63	M6	72.5	19	43	47	37.5	8	34.5	15	20	13.5	20	31
235421-*	ERX.63 SST-p-M6x30-*	63	M6	72.5	19	43	47	37.5	8	34.5	15	30	13.5	20	32
235426-*	ERX.63 SST-p-M6x40-*	63	M6	72.5	19	43	47	37.5	8	34.5	15	40	13.5	20	33
235431-*	ERX.63 SST-p-M8x16-*	63	M8	72.5	19	43	47	37.5	8	34.5	15	16	13.5	20	31
235436-*	ERX.63 SST-p-M8x20-*	63	M8	72.5	19	43	47	37.5	8	34.5	15	20	13.5	20	32
235441-*	ERX.63 SST-p-M8x25-*	63	M8	72.5	19	43	47	37.5	8	34.5	15	25	13.5	20	33
235446-*	ERX.63 SST-p-M8x30-*	63	M8	72.5	19	43	47	37.5	8	34.5	15	30	13.5	20	37
235451-*	ERX.63 SST-p-M8x35-*	63	M8	72.5	19	43	47	37.5	8	34.5	15	35	13.5	20	38
235456-*	ERX.63 SST-p-M8x40-*	63	M8	72.5	19	43	47	37.5	8	34.5	15	40	13.5	20	41
235461-*	ERX.63 SST-p-M8x45-*	63	M8	72.5	19	43	47	37.5	8	34.5	15	45	13.5	20	42
235466-*	ERX.63 SST-p-M8x50-*	63	M8	72.5	19	43	47	37.5	8	34.5	15	50	13.5	20	44
235471-*	ERX.63 SST-p-M8x60-*	63	M8	72.5	19	43	47	37.5	8	34.5	15	60	13.5	20	47
235476-*	ERX.63 SST-p-M8x70-*	63	M8	72.5	19	43	47	37.5	8	34.5	15	70	13.5	20	52
235601-*	ERX.78 SST-p-M8x20-*	78	M8	89.5	23	54	58	47	12	44	19	20	16	24	43
235603-*	ERX.78 SST-p-M8x25-*	78	M8	89.5	23	54	58	47	12	44	19	25	16	24	44
235605-*	ERX.78 SST-p-M8x30-*	78	M8	89.5	23	54	58	47	12	44	19	30	16	24	45
235607-*	ERX.78 SST-p-M8x40-*	78	M8	89.5	23	54	58	47	12	44	19	40	16	24	50
235609-*	ERX.78 SST-p-M8x45-*	78	M8	89.5	23	54	58	47	12	44	19	45	16	24	52
235611-*	ERX.78 SST-p-M8x50-*	78	M8	89.5	23	54	58	47	12	44	19	50	16	24	54
235617-*	ERX.78 SST-p-M8x70-*	78	M8	89.5	23	54	58	47	12	44	19	70	16	24	62
235618-*	ERX.78 SST-p-M8x80-*	78	M8	89.5	23	54	58	47	12	44	19	80	16	24	64
235716-*	ERX.78 SST-p-M10x20-*	78	M10	89.5	23	54	58	47	12	44	19	20	16	24	58
235726-*	ERX.78 SST-p-M10x30-*	78	M10	89.5	23	54	58	47	12	44	19	30	16	24	64
235731-*	ERX.78 SST-p-M10x35-*	78	M10	89.5	23	54	58	47	12	44	19	35	16	24	66
235736-*	ERX.78 SST-p-M10x40-*	78	M10	89.5	23	54	58	47	12	44	19	40	16	24	67
235741-*	ERX.78 SST-p-M10x50-*	78	M10	89.5	23	54	58	47	12	44	19	50	16	24	68
235746-*	ERX.78 SST-p-M10x60-*	78	M10	89.5	23	54	58	47	12	44	19	60	16	24	70
235771-*	ERX.78 SST-p-M12x30-*	78	M12	89.5	23	54	58	47	12	44	19	30	16	24	74
235773-*	ERX.78 SST-p-M12x35-*	78	M12	89.5	23	54	58	47	12	44	19	35	16	24	76
235781-*	ERX.78 SST-p-M12x40-*	78	M12	89.5	23	54	58	47	12	44	19	40	16	24	77
235786-*	ERX.78 SST-p-M12x50-*	78	M12	89.5	23	54	58	47	12	44	19	50	16	24	79
235893-*	ERX.78 SST-p-M12x70-*	78	M12	89.5	23	54	58	47	12	44	19	70	16	24	82
235901-*	ERX.95 SST-p-M12x30-*	95	M12	108	26	64.5	69	54.5	13	53	21.5	30	18	26	87
235911-*	ERX.95 SST-p-M12x40-*	95	M12	108	26	64.5	69	54.5	13	53	21.5	40	18	26	90
235921-*	ERX.95 SST-p-M12x50-*	95	M12	108	26	64.5	69	54.5	13	53	21.5	50	18	26	93
235941-*	ERX.95 SST-p-M12x70-*	95	M12	108	26	64.5	69	54.5	13	53	21.5	70	18	26	98
236001-*	ERX.108 SST-p-M12x30-*	108	M12	123	30	65.5	70	54.5	11	52.5	25	30	20	28	70
236003-*	ERX.108 SST-p-M12x40-*	108	M12	123	30	65.5	70	54.5	11	52.5	25	40	20	28	73
236006-*	ERX.108 SST-p-M12x50-*	108	M12	123	30	65.5	70	54.5	11	52.5	25	50	20	28	75
236011-*	ERX.108 SST-p-M12x70-*	108	M12	123	30	65.5	70	54.5	11	52.5	25	70	20	28	80



Clamping handles

- 1
- 2
- 3
- 4
- 5
- 6
- 7
- 8
- 9
- 10
- 11
- 12
- 13
- 14
- 15
- 16
- 17
- 18
- 19

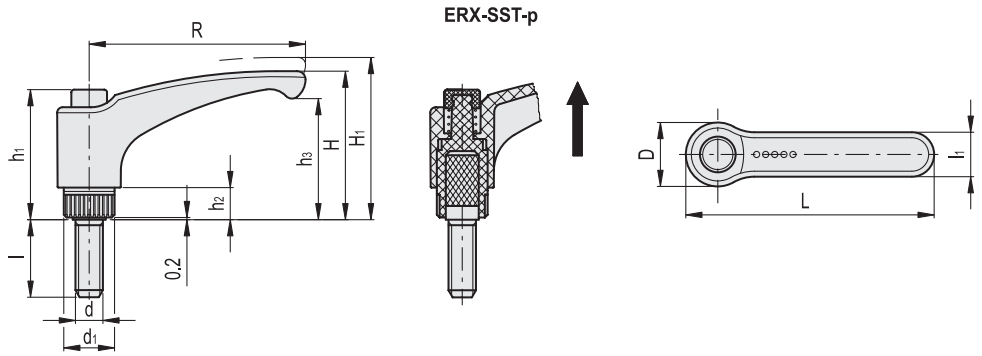

**Conversion Table**  
1 mm = 0.039 inch

R	
mm	inch
30	1.18
44	1.73
63	2.48
78	3.07
95	3.74
108	4.25

\*Complete with colour index, example: 235061-C2-C1 ERX.30-C2-SST-p M5x10-C1

C2 RAL2004    C3 RAL7035    C4 RAL1021    C5 RAL5024    C6 RAL3000    C7 RAL6017

ERX-SST-p

**INOX** STAINLESS STEEL    **METRIC**

Code	Description	R	d6g	L	D	H	H1	h1	h2	h3	d1	l	l1	Teeth no.	
235061*-C1	ERX.30*-SST-p M5x10-C1	30	M5	37.5	15	30	33.5	29.5	6	23	12	10	9	18	6
235066*-C1	ERX.30*-SST-p M5x16-C1	30	M5	37.5	15	30	33.5	29.5	6	23	12	16	9	18	7
235196*-C1	ERX.30*-SST-p M6x10-C1	30	M6	37.5	15	30	33.5	29.5	6	23	12	10	9	18	8
235201*-C1	ERX.30*-SST-p-M6x16-C1	30	M6	37.5	15	30	33.5	29.5	6	23	12	16	9	18	9
235203*-C1	ERX.30*-SST-p-M6x20-C1	30	M6	37.5	15	30	33.5	29.5	6	23	12	20	9	18	10
235205*-C1	ERX.30*-SST-p-M6x25-C1	30	M6	37.5	15	30	33.5	29.5	6	23	12	25	9	18	11
235207*-C1	ERX.30*-SST-p-M6x30-C1	30	M6	37.5	15	30	33.5	29.5	6	23	12	30	9	18	12
235209*-C1	ERX.44*-SST-p-M5x10-C1	44	M5	52	16	32.5	36	29.5	6	25	12	10	11	18	10
235211*-C1	ERX.44*-SST-p-M5x16-C1	44	M5	52	16	32.5	36	29.5	6	25	12	16	11	18	12
235216*-C1	ERX.44*-SST-p-M6x10-C1	44	M6	52	16	32.5	36	29.5	6	25	12	10	11	18	13
235221*-C1	ERX.44*-SST-p-M6x16-C1	44	M6	52	16	32.5	36	29.5	6	25	12	16	11	18	14
235226*-C1	ERX.44*-SST-p-M6x20-C1	44	M6	52	16	32.5	36	29.5	6	25	12	20	11	18	16
235231*-C1	ERX.44*-SST-p-M6x25-C1	44	M6	52	16	32.5	36	29.5	6	25	12	25	11	18	17
235236*-C1	ERX.44*-SST-p-M6x30-C1	44	M6	52	16	32.5	36	29.5	6	25	12	30	11	18	18
235341*-C1	ERX.63*-SST-p-M6x10-C1	63	M6	72.5	19	43	47	37.5	8	34.5	15	10	13.5	20	30
235351*-C1	ERX.63*-SST-p-M6x20-C1	63	M6	72.5	19	43	47	37.5	8	34.5	15	20	13.5	20	31
235421*-C1	ERX.63*-SST-p-M6x30-C1	63	M6	72.5	19	43	47	37.5	8	34.5	15	30	13.5	20	32
235426*-C1	ERX.63*-SST-p-M6x40-C1	63	M6	72.5	19	43	47	37.5	8	34.5	15	40	13.5	20	33
235431*-C1	ERX.63*-SST-p-M8x16-C1	63	M8	72.5	19	43	47	37.5	8	34.5	15	16	13.5	20	31
235436*-C1	ERX.63*-SST-p-M8x20-C1	63	M8	72.5	19	43	47	37.5	8	34.5	15	20	13.5	20	32
235441*-C1	ERX.63*-SST-p-M8x25-C1	63	M8	72.5	19	43	47	37.5	8	34.5	15	25	13.5	20	33
235446*-C1	ERX.63*-SST-p-M8x30-C1	63	M8	72.5	19	43	47	37.5	8	34.5	15	30	13.5	20	37
235451*-C1	ERX.63*-SST-p-M8x35-C1	63	M8	72.5	19	43	47	37.5	8	34.5	15	35	13.5	20	38
235456*-C1	ERX.63*-SST-p-M8x40-C1	63	M8	72.5	19	43	47	37.5	8	34.5	15	40	13.5	20	41
235461*-C1	ERX.63*-SST-p-M8x45-C1	63	M8	72.5	19	43	47	37.5	8	34.5	15	45	13.5	20	42
235466*-C1	ERX.63*-SST-p-M8x50-C1	63	M8	72.5	19	43	47	37.5	8	34.5	15	50	13.5	20	44
235471*-C1	ERX.63*-SST-p-M8x60-C1	63	M8	72.5	19	43	47	37.5	8	34.5	15	60	13.5	20	47
235476*-C1	ERX.63*-SST-p-M8x70-C1	63	M8	72.5	19	43	47	37.5	8	34.5	15	70	13.5	20	52

Clamping handles



Conversion Table	
1 mm = 0.039 inch	
R	
mm	inch
30	1.18
44	1.73
63	2.48
78	3.07
95	3.74
108	4.25



\* Complete with colour index, example: 235341-C2-C1 ERX.63-C2 SST-p-M6x10-C1

C2	C3	C4	C5	C6	C17
RAL2004	RAL7035	RAL1021	RAL5024	RAL3000	RAL6017

ERX-SST-p

**INOX** STAINLESS STEEL **METRIC**

Code	Description	R	d6g	L	D	H	H1	h1	h2	h3	d1	l	l1	Teeth no.	
235601*-C1	ERX.78*-SST-p-M8x20-C1	78	M8	89.5	23	54	58	47	12	44	19	20	16	24	43
235603*-C1	ERX.78*-SST-p-M8x25-C1	78	M8	89.5	23	54	58	47	12	44	19	25	16	24	44
235605*-C1	ERX.78*-SST-p-M8x30-C1	78	M8	89.5	23	54	58	47	12	44	19	30	16	24	45
235607*-C1	ERX.78*-SST-p-M8x40-C1	78	M8	89.5	23	54	58	47	12	44	19	40	16	24	50
235609*-C1	ERX.78*-SST-p-M8x45-C1	78	M8	89.5	23	54	58	47	12	44	19	45	16	24	52
235611*-C1	ERX.78*-SST-p-M8x50-C1	78	M8	89.5	23	54	58	47	12	44	19	50	16	24	54
235617*-C1	ERX.78*-SST-p-M8x70-C1	78	M8	89.5	23	54	58	47	12	44	19	70	16	24	62
235618*-C1	ERX.78*-SST-p-M8x80-C1	78	M8	89.5	23	54	58	47	12	44	19	80	16	24	64
235716*-C1	ERX.78*-SST-p-M10x20-C1	78	M10	89.5	23	54	58	47	12	44	19	20	16	24	58
235726*-C1	ERX.78*-SST-p-M10x30-C1	78	M10	89.5	23	54	58	47	12	44	19	30	16	24	64
235731*-C1	ERX.78*-SST-p-M10x35-C1	78	M10	89.5	23	54	58	47	12	44	19	35	16	24	66
235736*-C1	ERX.78*-SST-p-M10x40-C1	78	M10	89.5	23	54	58	47	12	44	19	40	16	24	67
235741*-C1	ERX.78*-SST-p-M10x50-C1	78	M10	89.5	23	54	58	47	12	44	19	50	16	24	68
235746*-C1	ERX.78*-SST-p-M10x60-C1	78	M10	89.5	23	54	58	47	12	44	19	60	16	24	70
235771*-C1	ERX.78*-SST-p-M12x30-C1	78	M12	89.5	23	54	58	47	12	44	19	30	16	24	74
235773*-C1	ERX.78*-SST-p-M12x35-C1	78	M12	89.5	23	54	58	47	12	44	19	35	16	24	76
235781*-C1	ERX.78*-SST-p-M12x40-C1	78	M12	89.5	23	54	58	47	12	44	19	40	16	24	77
235786*-C1	ERX.78*-SST-p-M12x50-C1	78	M12	89.5	23	54	58	47	12	44	19	50	16	24	79
235893*-C1	ERX.78*-SST-p-M12x70-C1	78	M12	89.5	23	54	58	47	12	44	19	70	16	24	82
235901*-C1	ERX.95*-SST-p-M12x30-C1	95	M12	108	26	64.5	69	54.5	13	53	21.5	30	18	26	87
235911*-C1	ERX.95*-SST-p-M12x40-C1	95	M12	108	26	64.5	69	54.5	13	53	21.5	40	18	26	90
235921*-C1	ERX.95*-SST-p-M12x50-C1	95	M12	108	26	64.5	69	54.5	13	53	21.5	50	18	26	93
235941*-C1	ERX.95*-SST-p-M12x70-C1	95	M12	108	26	64.5	69	54.5	13	53	21.5	70	18	26	98
236001*-C1	ERX.108*-SST-p-M12x30-C1	108	M12	123	30	65.5	70	54.5	11	52.5	25	30	20	28	70
236003*-C1	ERX.108*-SST-p-M12x40-C1	108	M12	123	30	65.5	70	54.5	11	52.5	25	40	20	28	73
236006*-C1	ERX.108*-SST-p-M12x50-C1	108	M12	123	30	65.5	70	54.5	11	52.5	25	50	20	28	75
236011*-C1	ERX.108*-SST-p-M12x70-C1	108	M12	123	30	65.5	70	54.5	11	52.5	25	70	20	28	80

Clamping handles