

# NOVASTACK® 35-HDN

Fully-shielded and narrow design, Good performance for RF transmission, Power supply is available with Corson Alloy contact, 0.35 mm pitch, 0.7mm height

**Product Specifications:**

Board Pitch (mm)		0.35
Wiping Length (mm)		0.14
Mated Size (mm)	Height	0.7 +/- 0.05
	Width	Formula: 4.15 (10 P), 5.90 (20 P), 7.90 (30 P)
	Depth	2.15 mm
Frequency		DC ~ 15 GHz
Current Rating	Signal	1.0 A / pin (Max. 10 P) (12 P and over : 12.0 A AC/DC (Total))
	Power	-
Pin Counts	Range	10 - 60
	Available	10, 20, 30

**Applicable Standards (Reference Only):**

USB4 (20 Gbps/lane) USB 3.1 Gen 2 (10 Gbps)

\* Please inquire for pin counts not listed or outside of the pin count range.



► **Supports high-frequency transmission; ensures good signal quality even for RF transmission.**

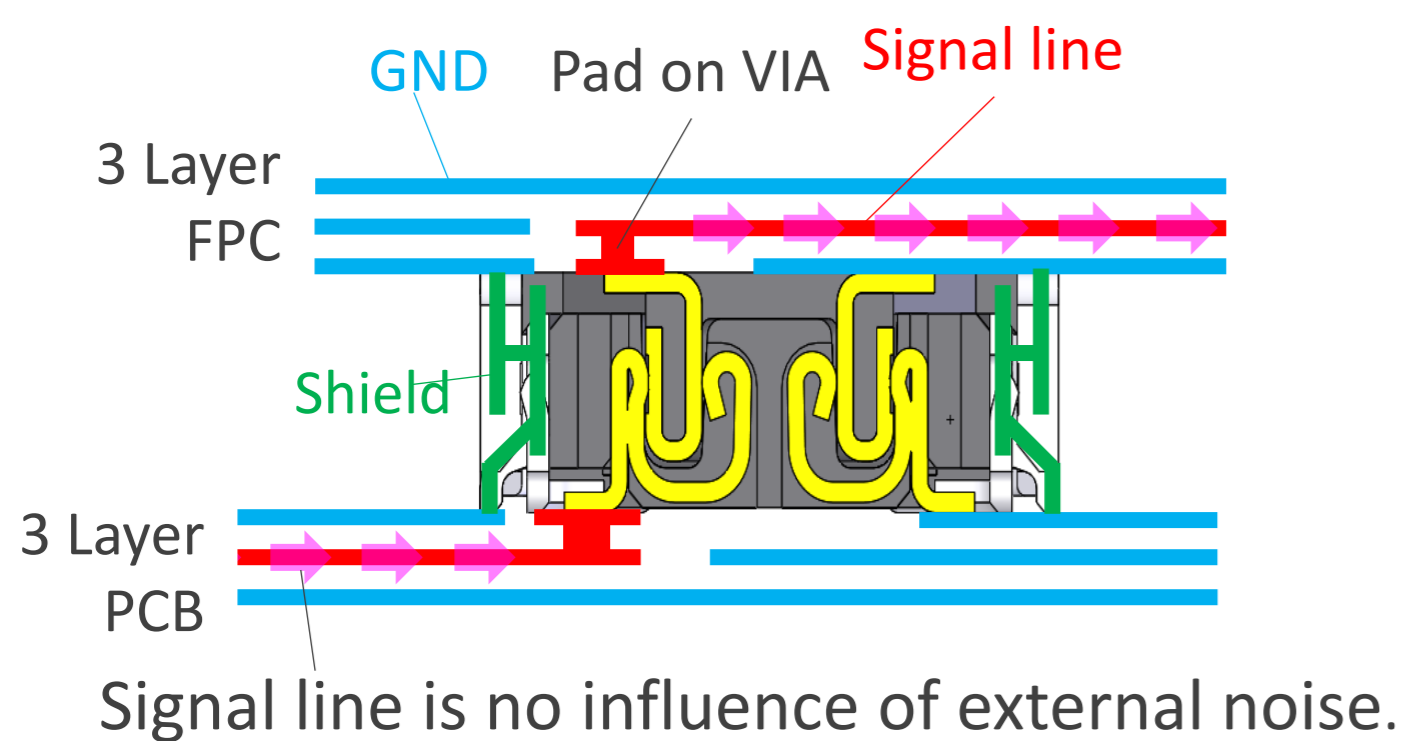

◆ **Pin assignment**

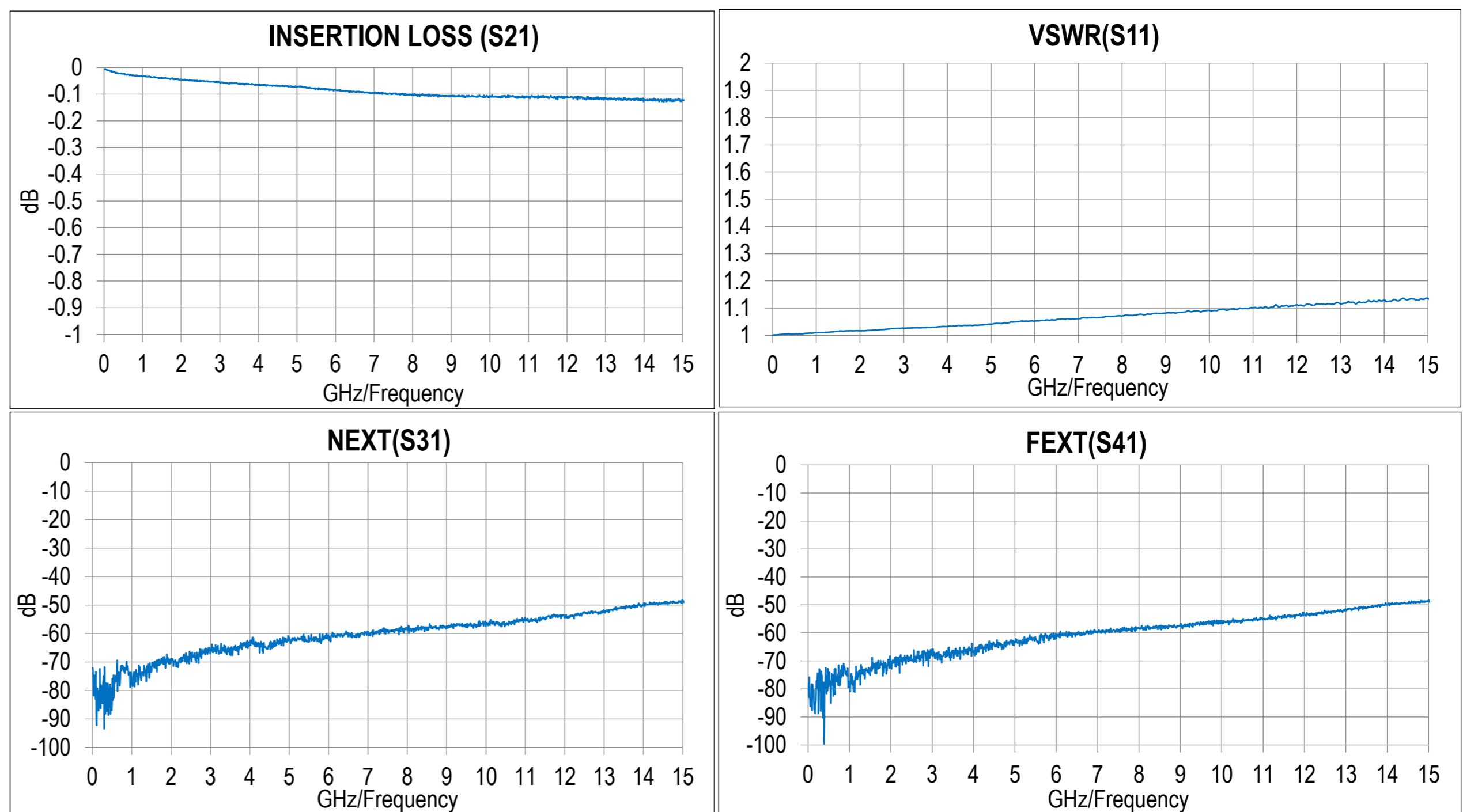

► **ZenShield® fully-shielded design is ideal for EMC solutions.**

E-Field comparison of adjacent signal lines with or without shields

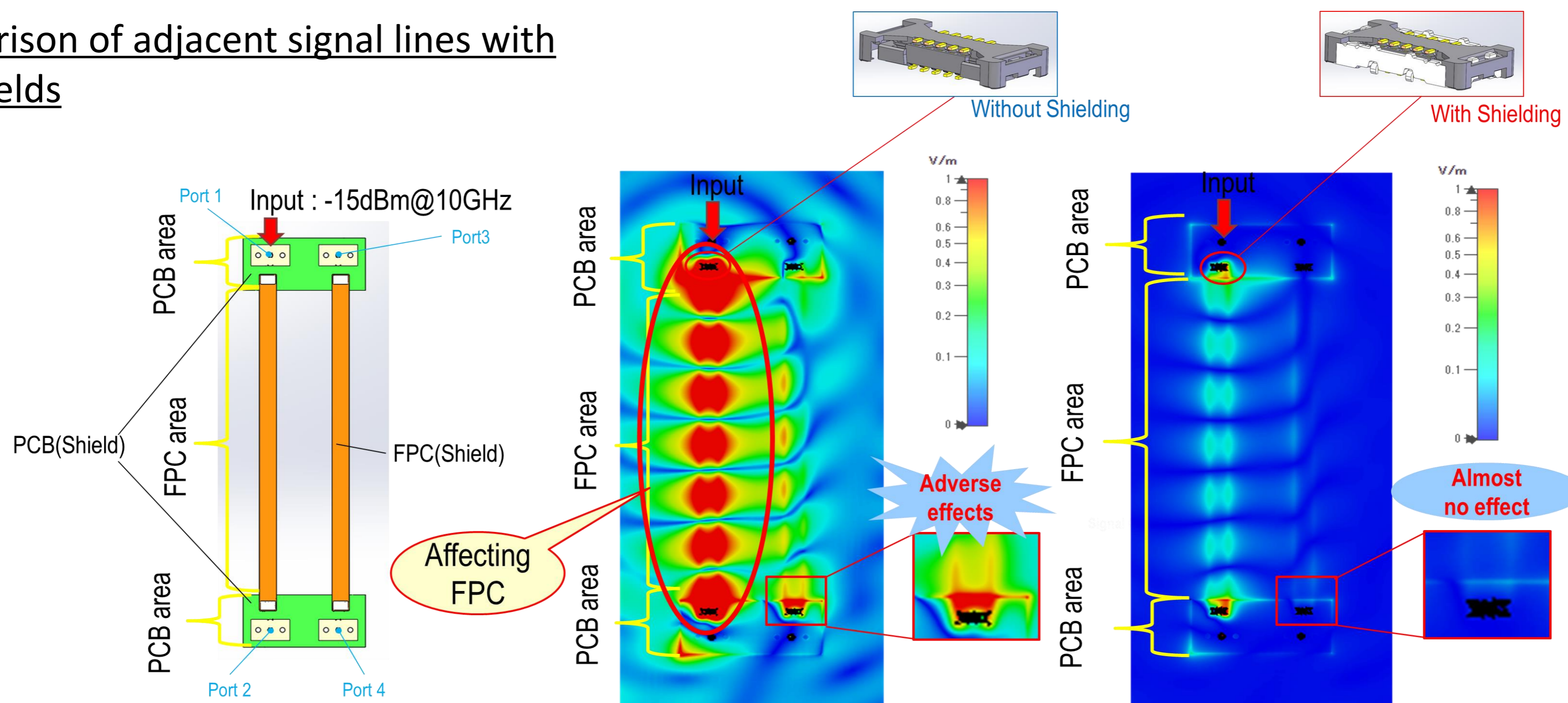

► **Compact and low-profile, optimized for use in space-constrained applications.**

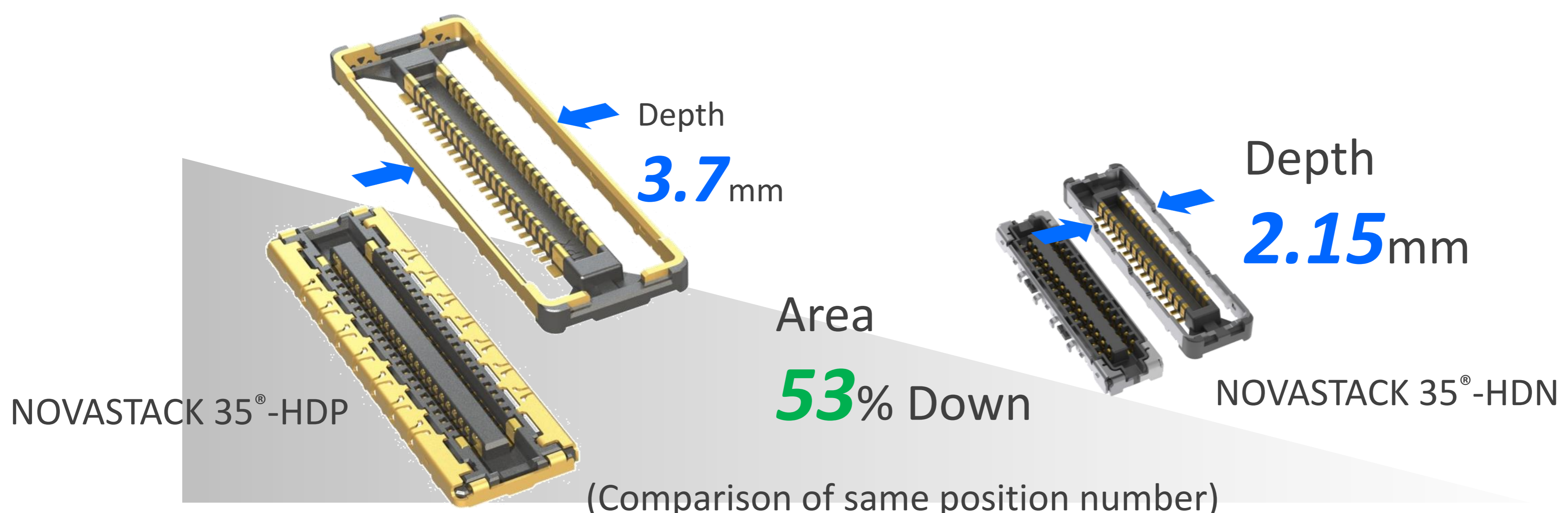

# Component Parts Detail

## Plug Assembly

Recommended P/N	20864-010E-01
PART NO.	Pos.
20864-010E-01	10

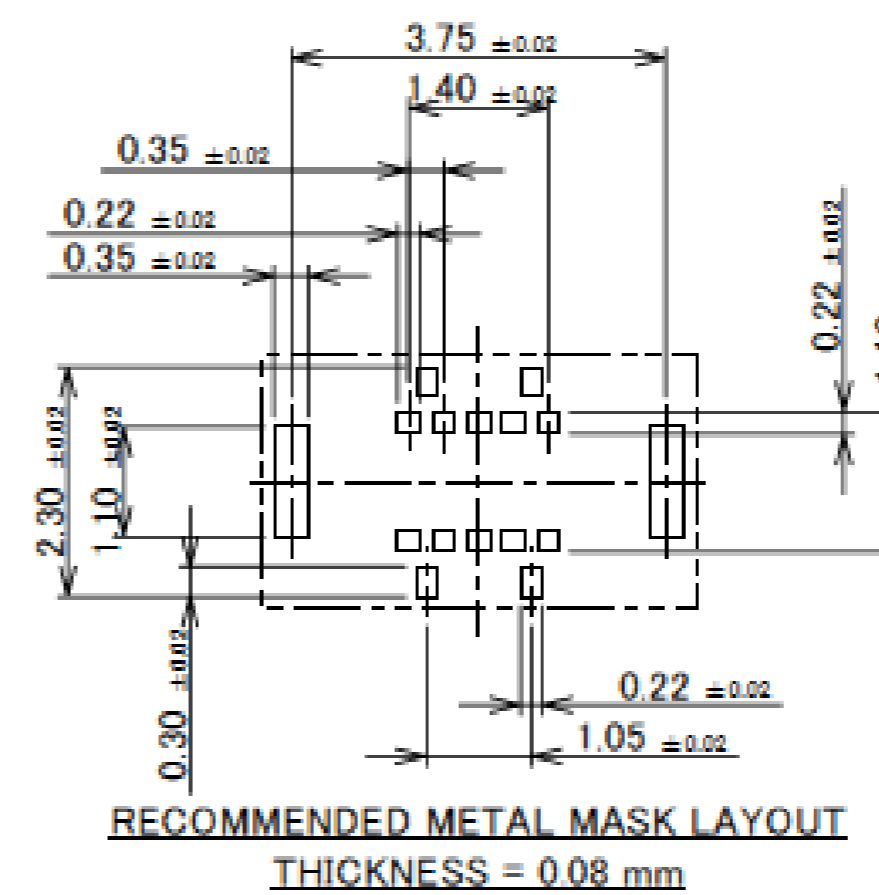
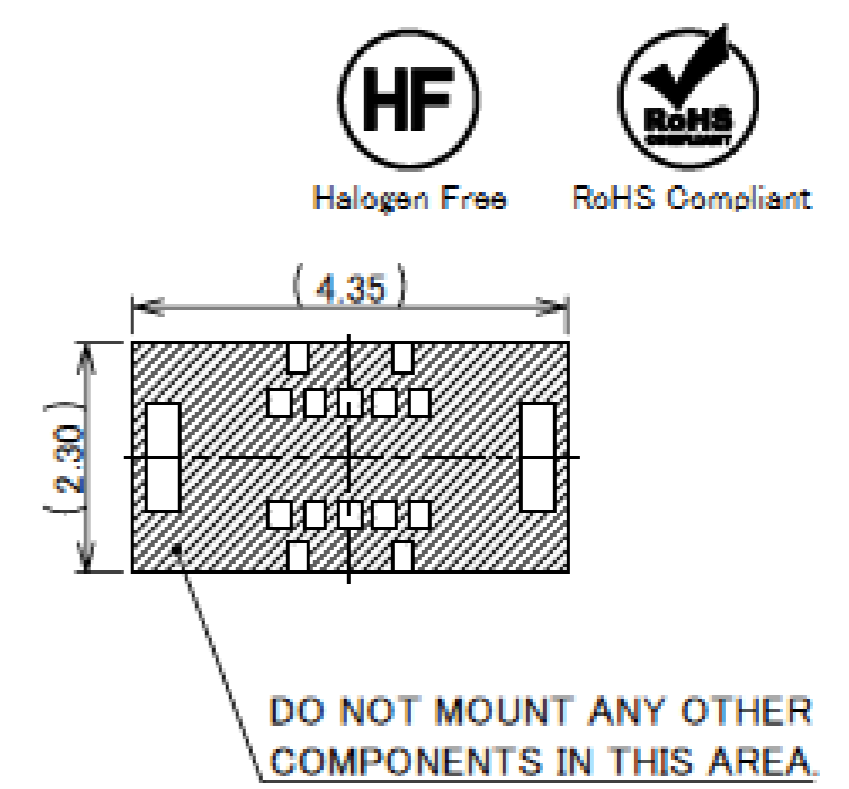
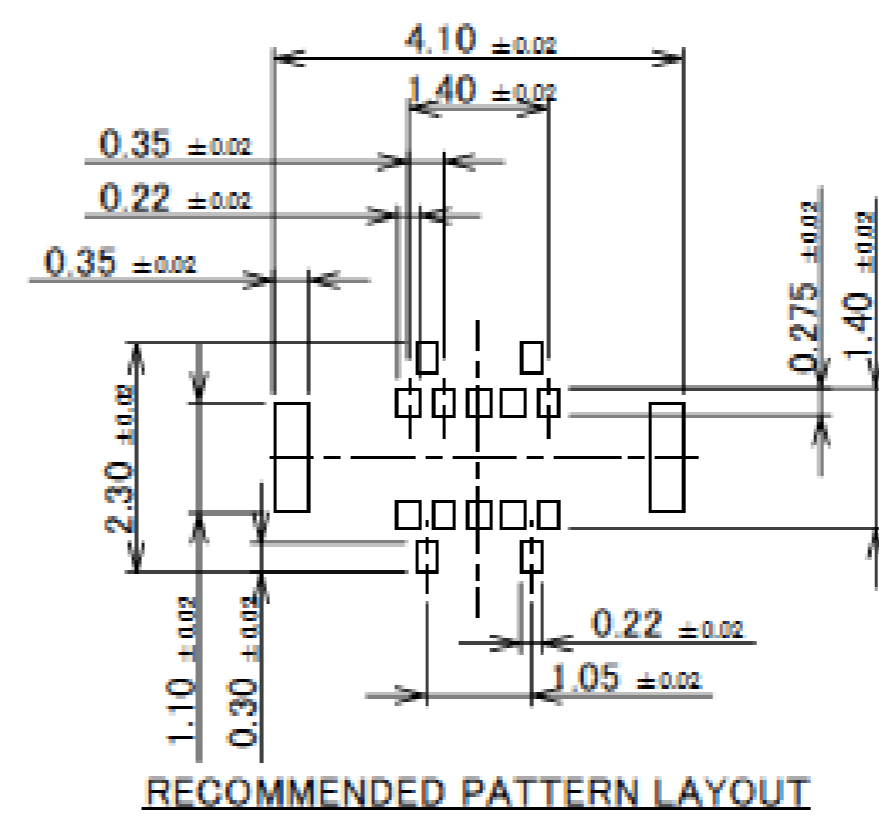
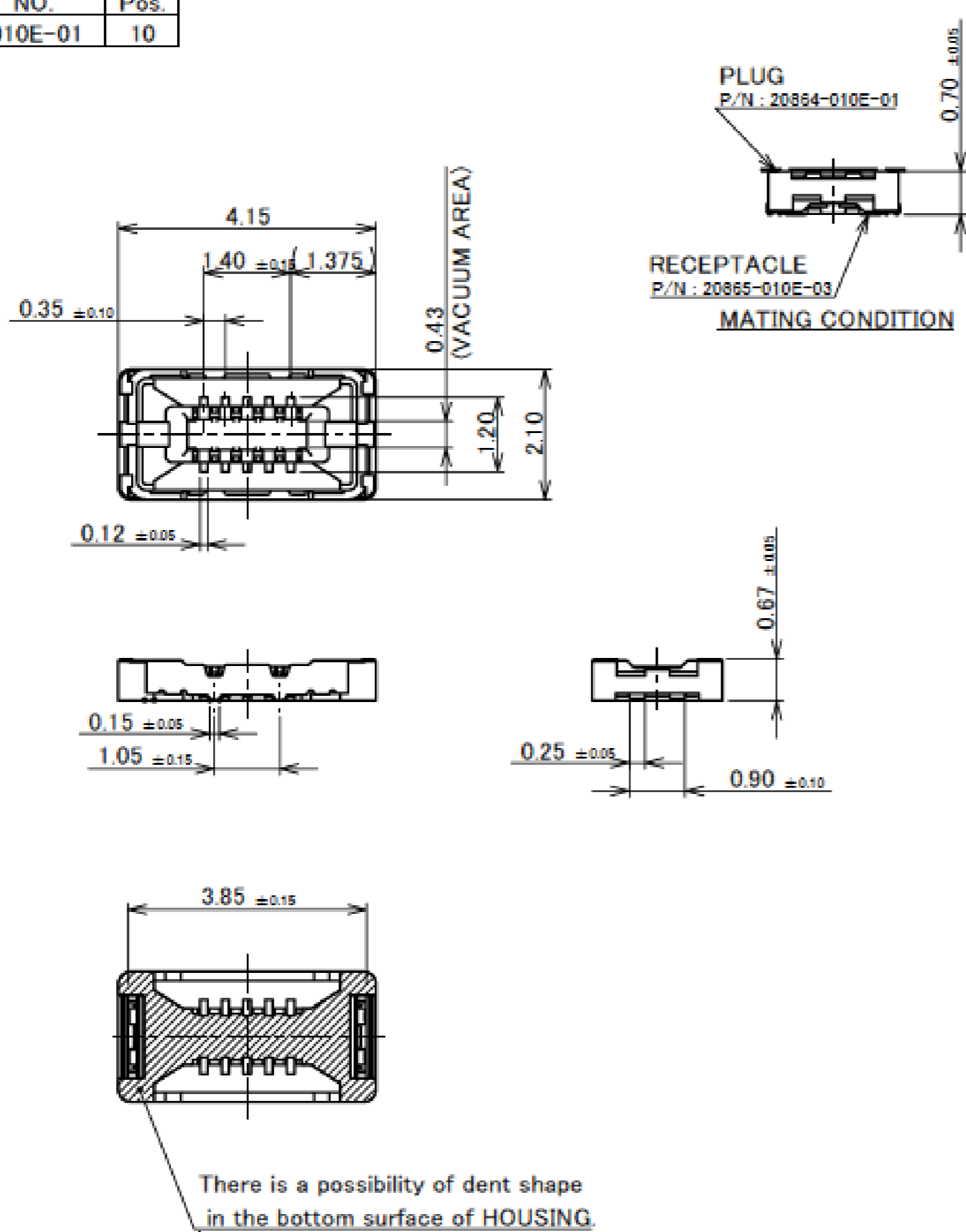

NO.	DISCRIPTION	MATERIAL	FINISH, REMARKS
3	SHELL	COPPER ALLOY	SOLDERING PART Au 0.01 μm MIN. OVER Ni 1.27 μm MIN.
2	CONTACT	COPPER ALLOY	CONTACT PART Au 0.05 μm MIN. OVER Ni 1.27 μm MIN. SOLDERING PART Au 0.01 μm MIN. OVER Ni 1.27 μm MIN.
1	HOUSING	LCP	UL94V-0, BLACK

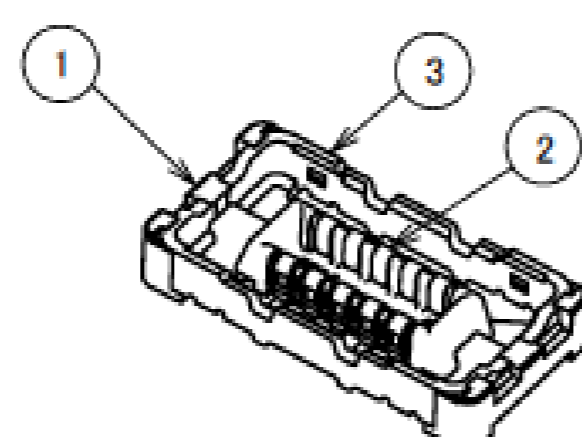

# Plug Assembly

Recommended P/N	20864-020E-01
PART NO.	Pos.
20864-020E-01	20

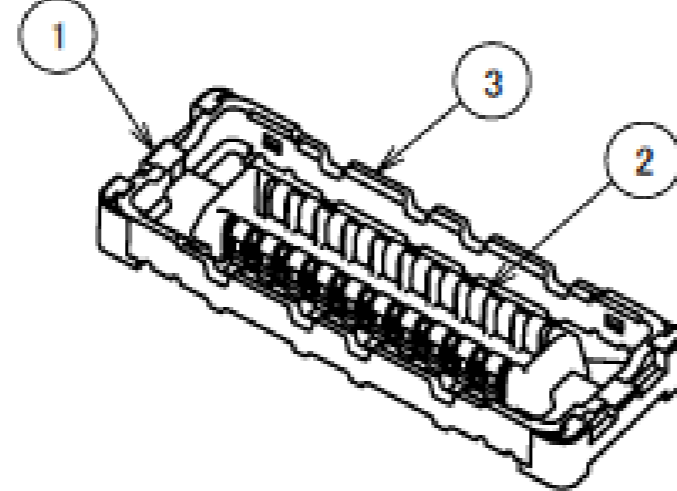
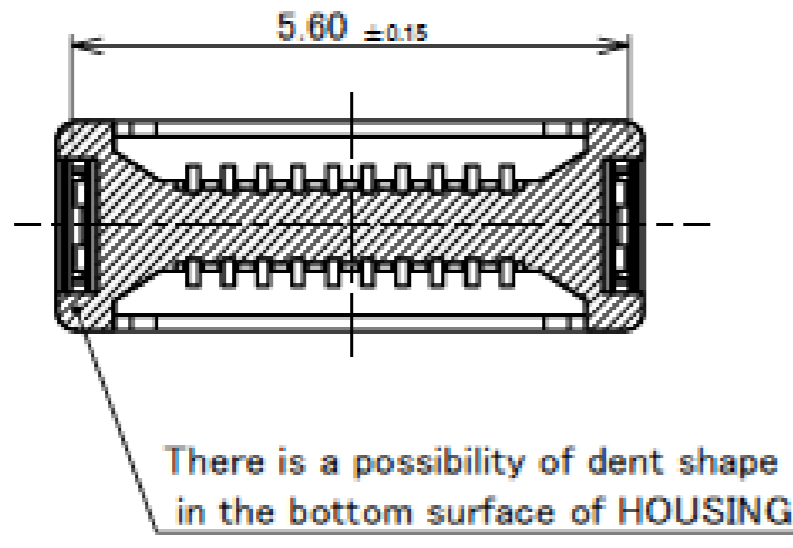
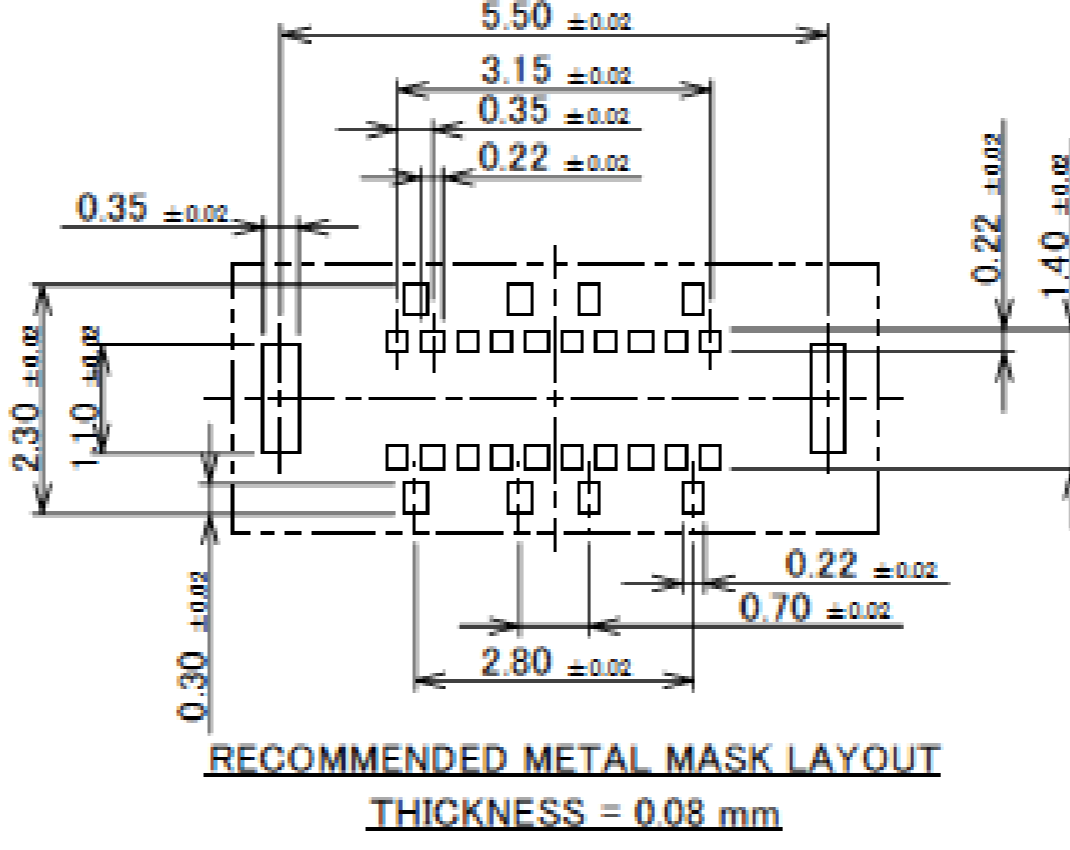
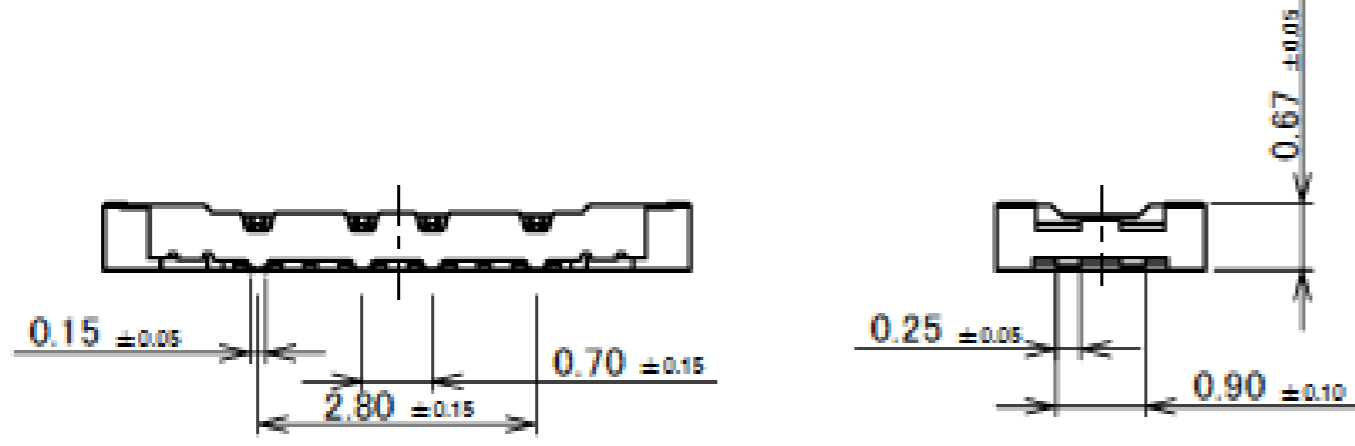
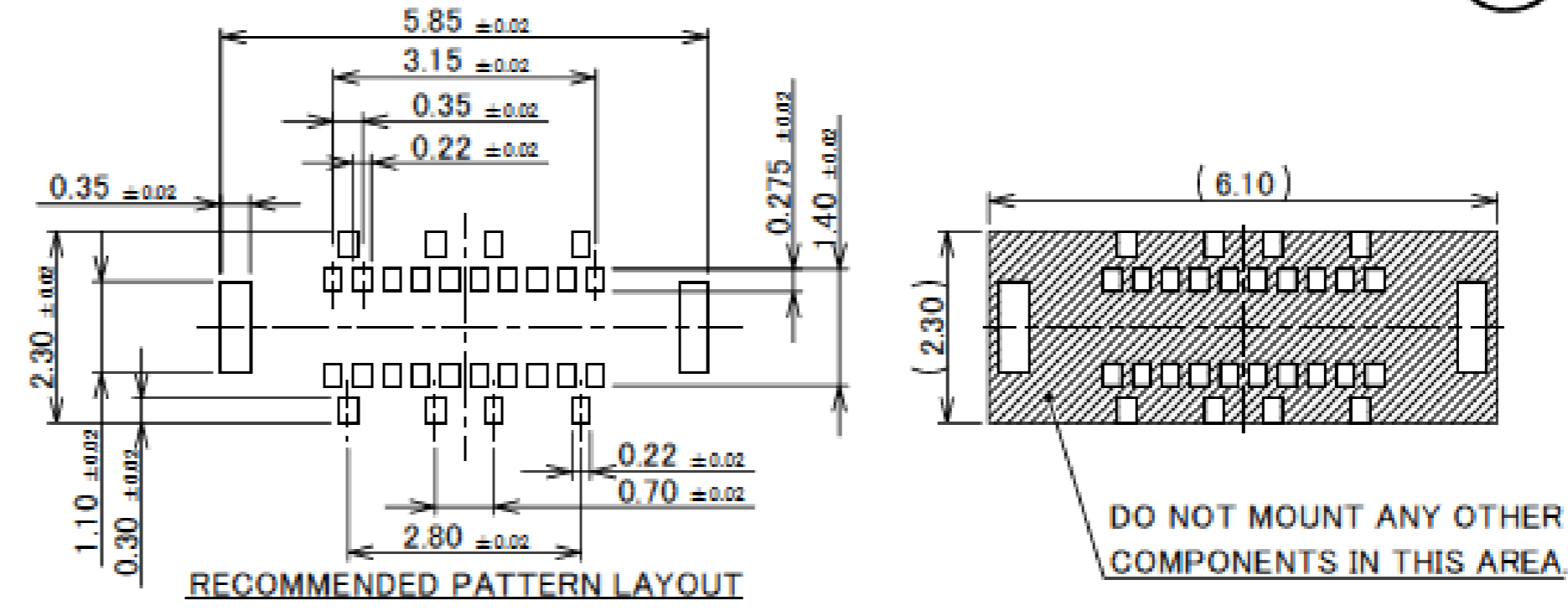
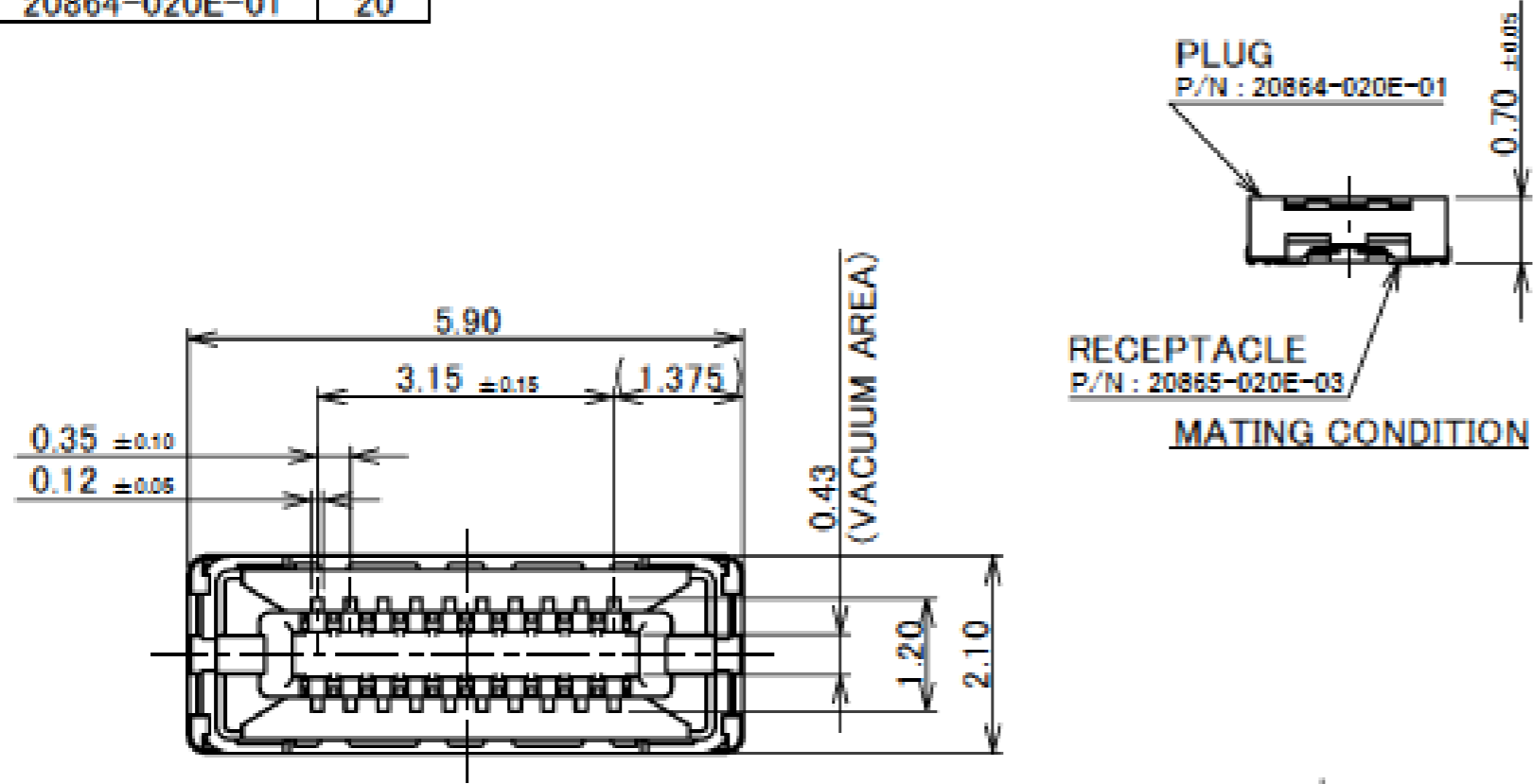

3	SHELL	COPPER ALLOY	SOLDERING PART Au 0.01 μm MIN. OVER Ni 1.27 μm MIN.
2	CONTACT	COPPER ALLOY	CONTACT PART Au 0.05 μm MIN. OVER Ni 1.27 μm MIN. SOLDERING PART Au 0.01 μm MIN. OVER Ni 1.27 μm MIN.
1	HOUSING	LCP	UL94V-0, BLACK
NO.	DISCRIPTION	MATERIAL	FINISH, REMARKS

Rev.10

Recommended P/N	20864-030E-01
PART NO.	Pos.
20864-030E-01	30

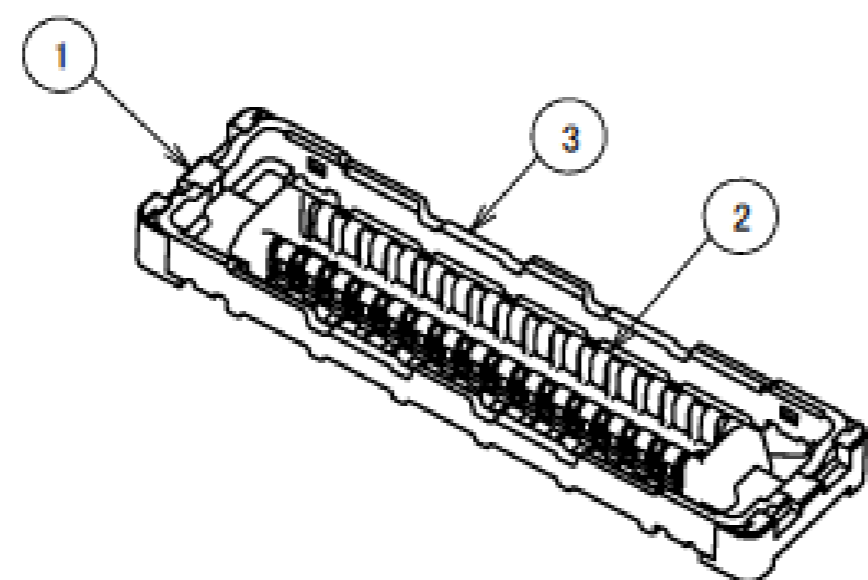
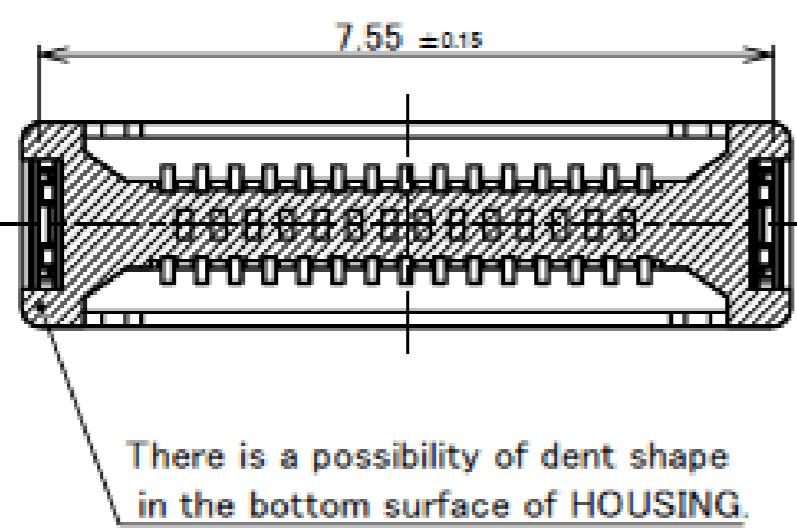
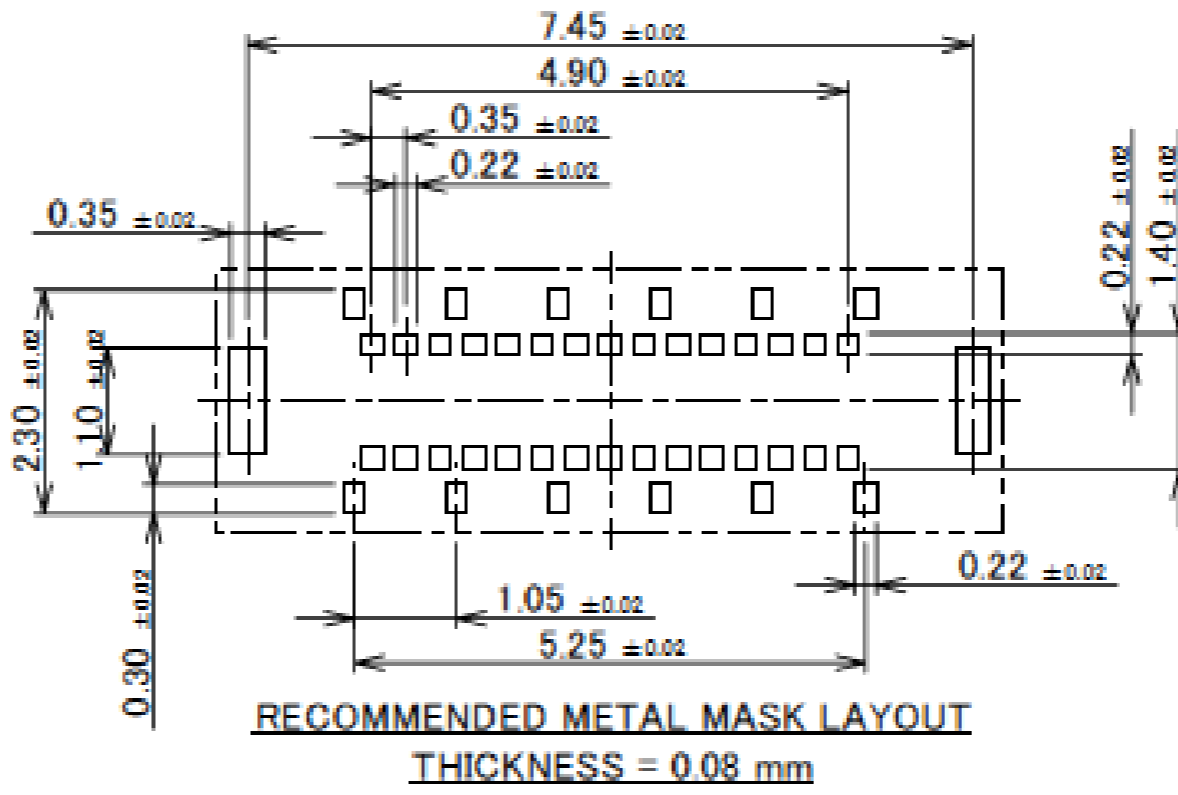
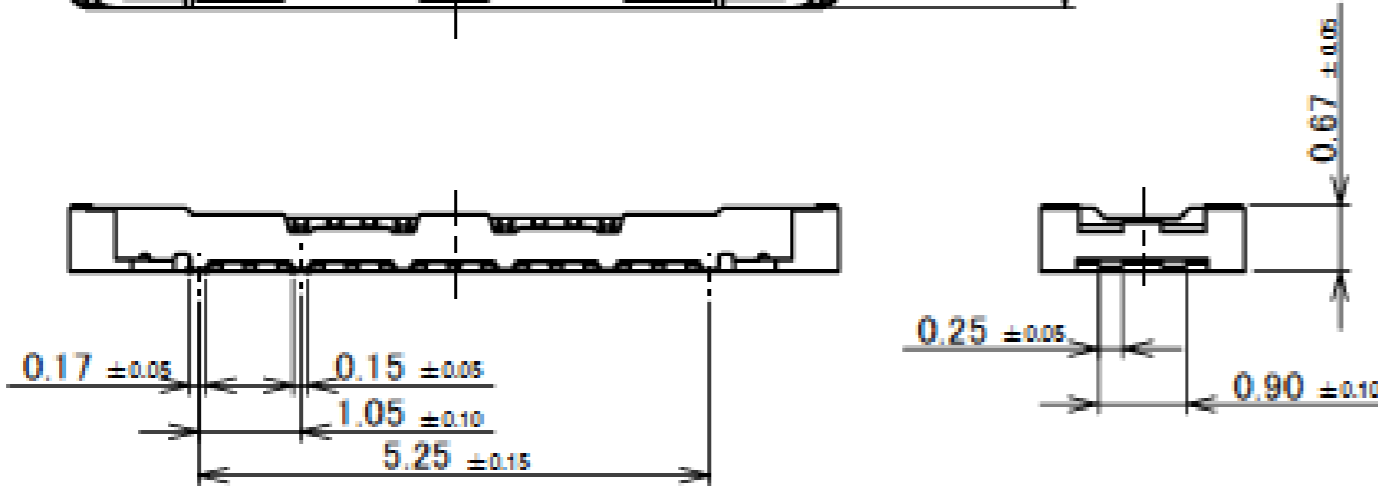
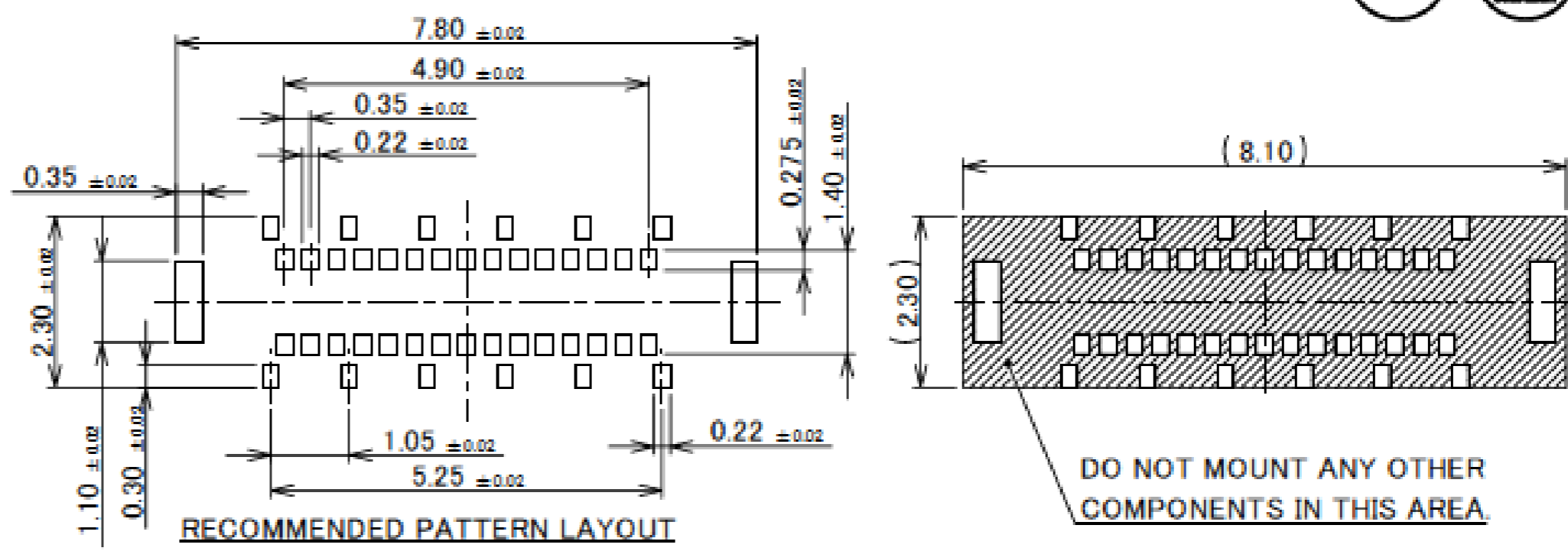
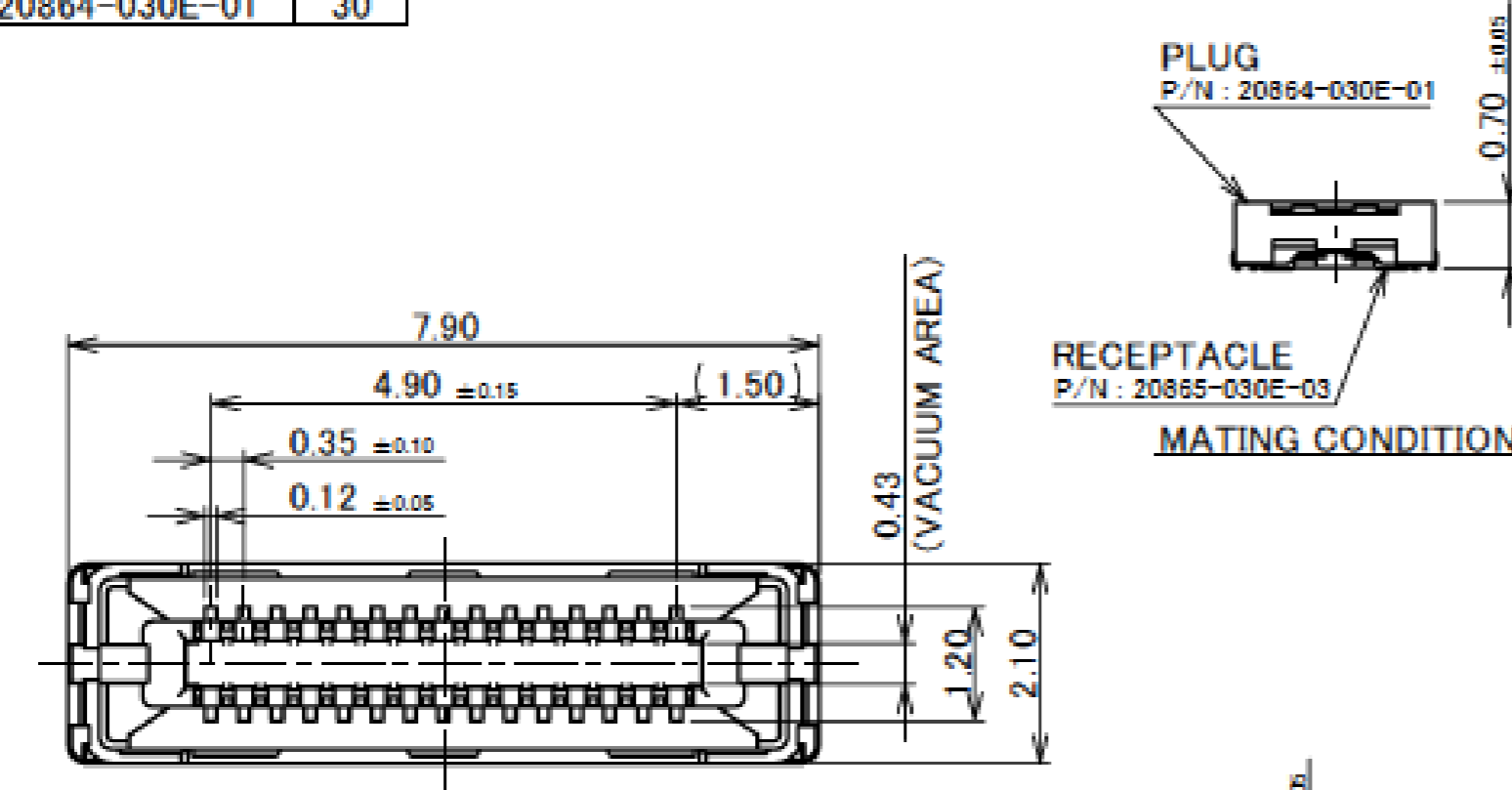

3	SHELL	COPPER ALLOY	SOLDERING PART Au 0.01 μm MIN. OVER Ni 1.27 μm MIN.
2	CONTACT	COPPER ALLOY	CONTACT PART Au 0.05 μm MIN. OVER Ni 1.27 μm MIN. SOLDERING PART Au 0.01 μm MIN. OVER Ni 1.27 μm MIN.
1	HOUSING	LCP	UL94V-0, BLACK
NO.	DISCRIPTION	MATERIAL	FINISH, REMARKS

Rev.10

# Plug Assembly

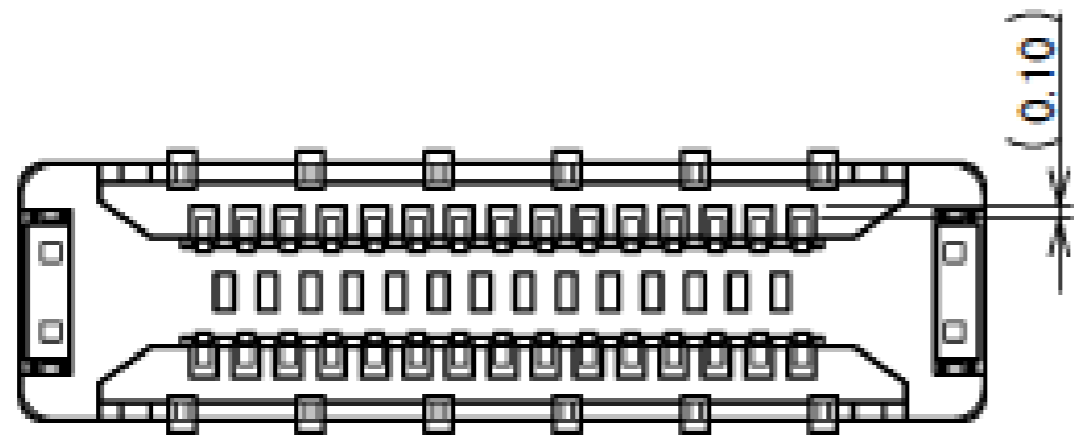

CONNECTOR ON RECOMMENDED FOOTPRINT PATTERN

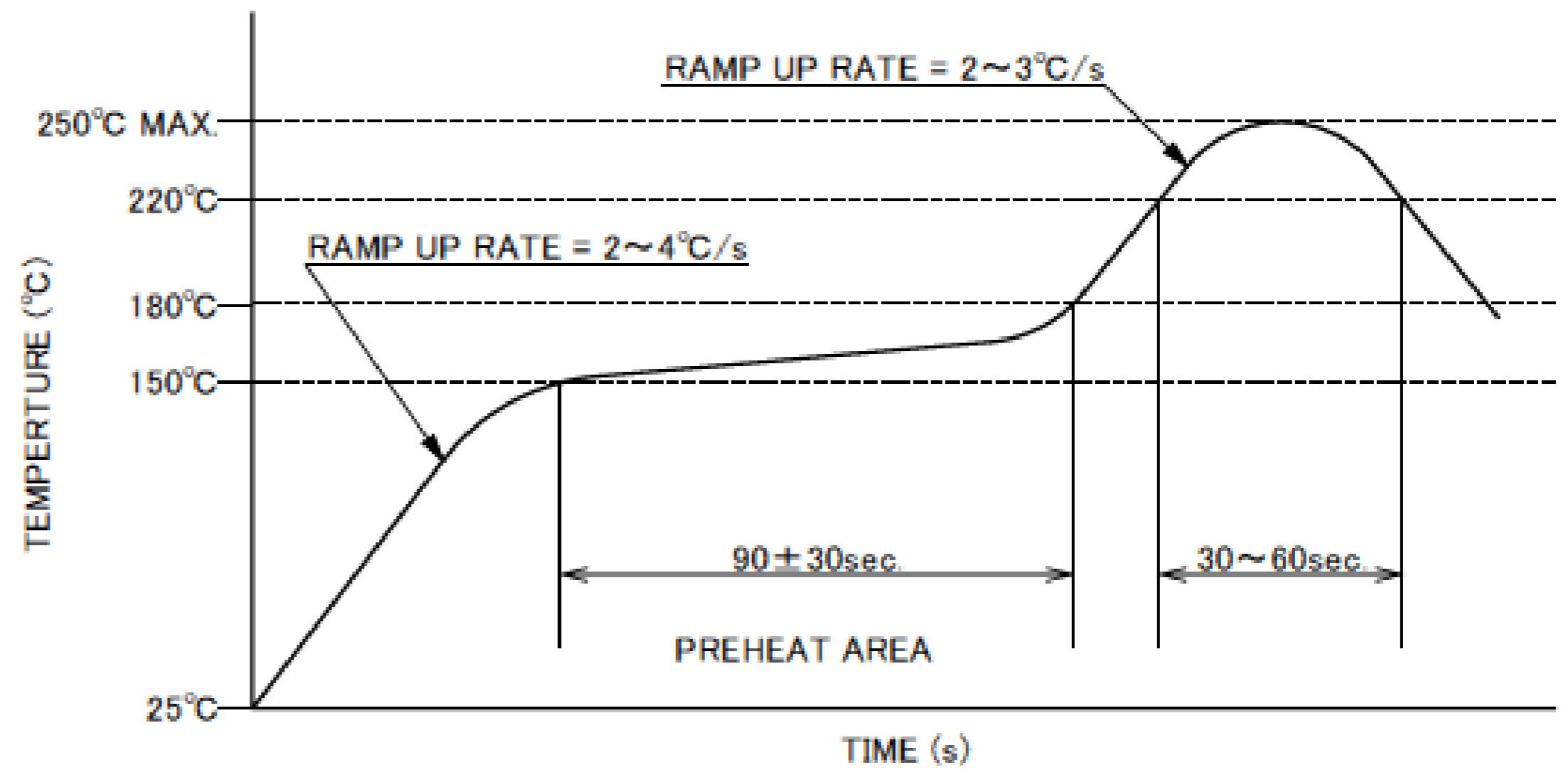

REFLOW TEMPERATURE PROFILE  
SENJU METAL INDUSTRY CO., LTD. : M705-SHF(Sn96.5 Ag3.0 Cu0.5)

Rev.10

ITEMS	SPECIFICATION
APPLICABLE CONNECTOR PART No.	20865-0**E-**
RATING VOLTAGE	60V AC(r.m.s) / DC (PER CONTACT PIN)
RATING AMPERAGE (FOR SIGNAL CONTACT)	10P:1.0 A MAX. AC/DC x PIN COUNTS = 10.0 A (TOTAL) 12P AND OVER : 12.0 A AC/DC (TOTAL)
OPERATING TEMPERATURE	233~358K(-40°C~85°C)
OPERATING HUMIDITY	85% MAX.(NON-CONDENDING)
CONTACT RESISTANCE (FOR SIGNAL CONTACT)	INITIAL : 40mohm MAX. / AFTER TEST : $\Delta$ 40mohm MAX.
CONTACT RESISTANCE (FOR GROUND)	INITIAL : 20mohm MAX. / AFTER TEST : $\Delta$ 20mohm MAX.
INSULATION RESISTANCE	INITIAL : 1,000Mohm MIN. / AFTER TEST : 500Mohm MIN.
DIELECTRIC WITHSTANDING VOLTAGE	AC250V 1min
DURABILITY	10 CYCLES
MATING FORCE (INITIAL / AFTER TEST)	INITIAL 2.0N/Pin MAX.
UNMATING FORCE (INITIAL / AFTER TEST)	10 CYCLES 0.15N/Pin MIN.
COPLANARITY	0.08 MAX
PRODUCT SPECIFICATION	PRS-2607
TEST REPORT	TR-19055
PACKING STANDARD	PST-18022
INSTRUCTION MANUAL	HIM-18019
APPEARANCE CRITERIA No.	QLS-A***

Rev.10

# Receptacle Assembly

Recommended P/N		20865-010E-03
PART NO.	Pos.	
20865-010E-03	10	

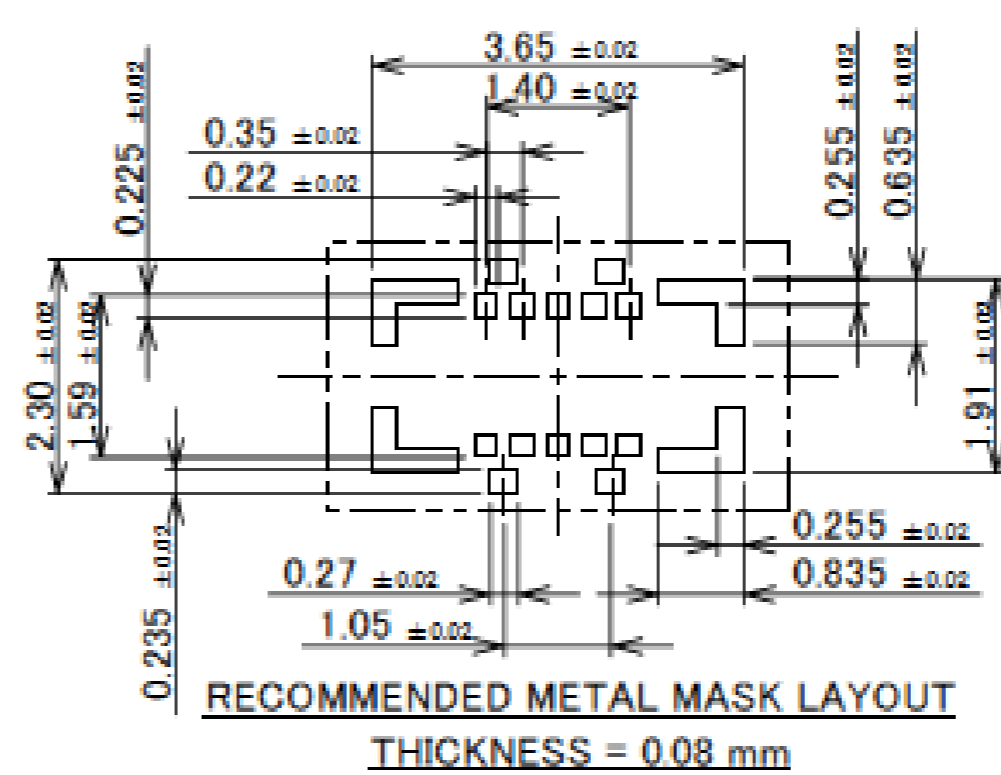
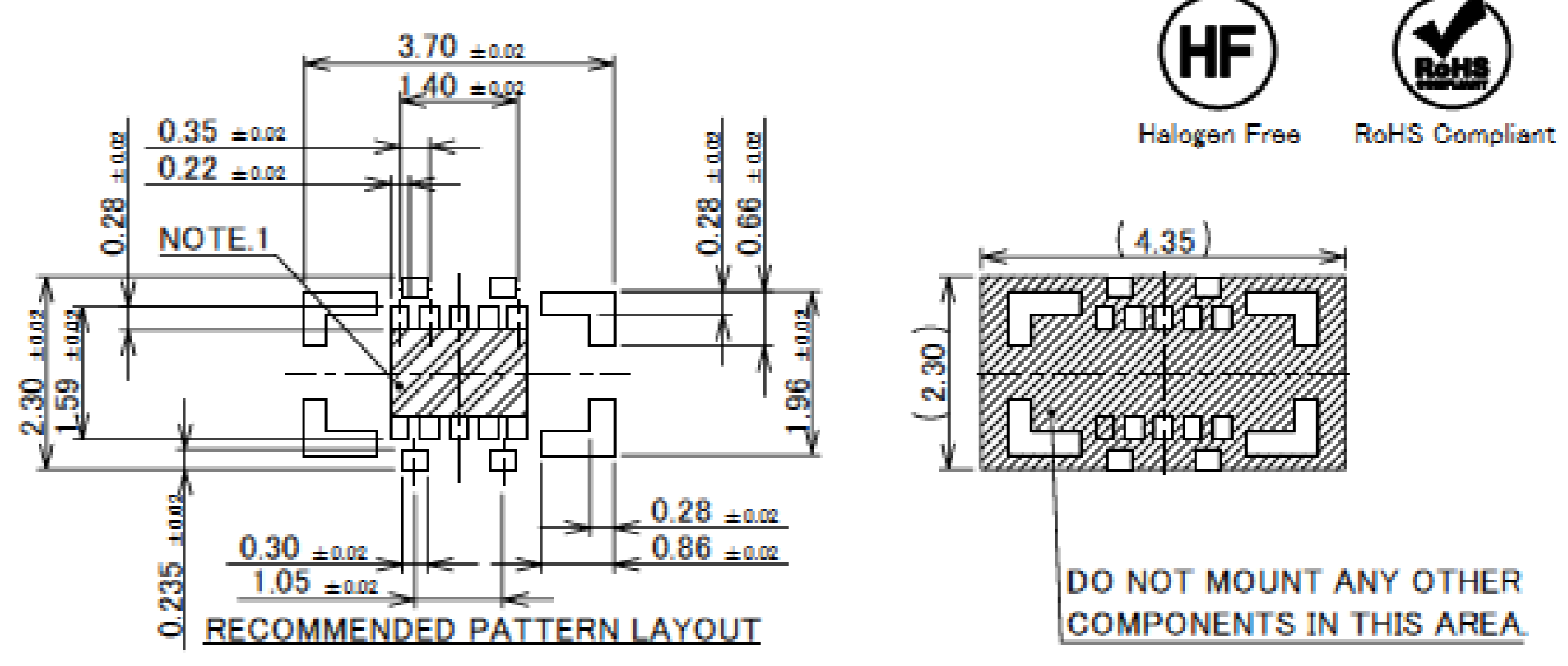
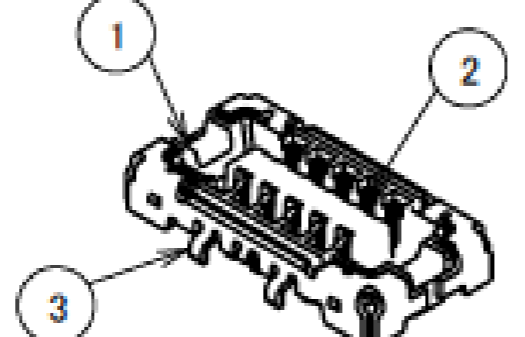
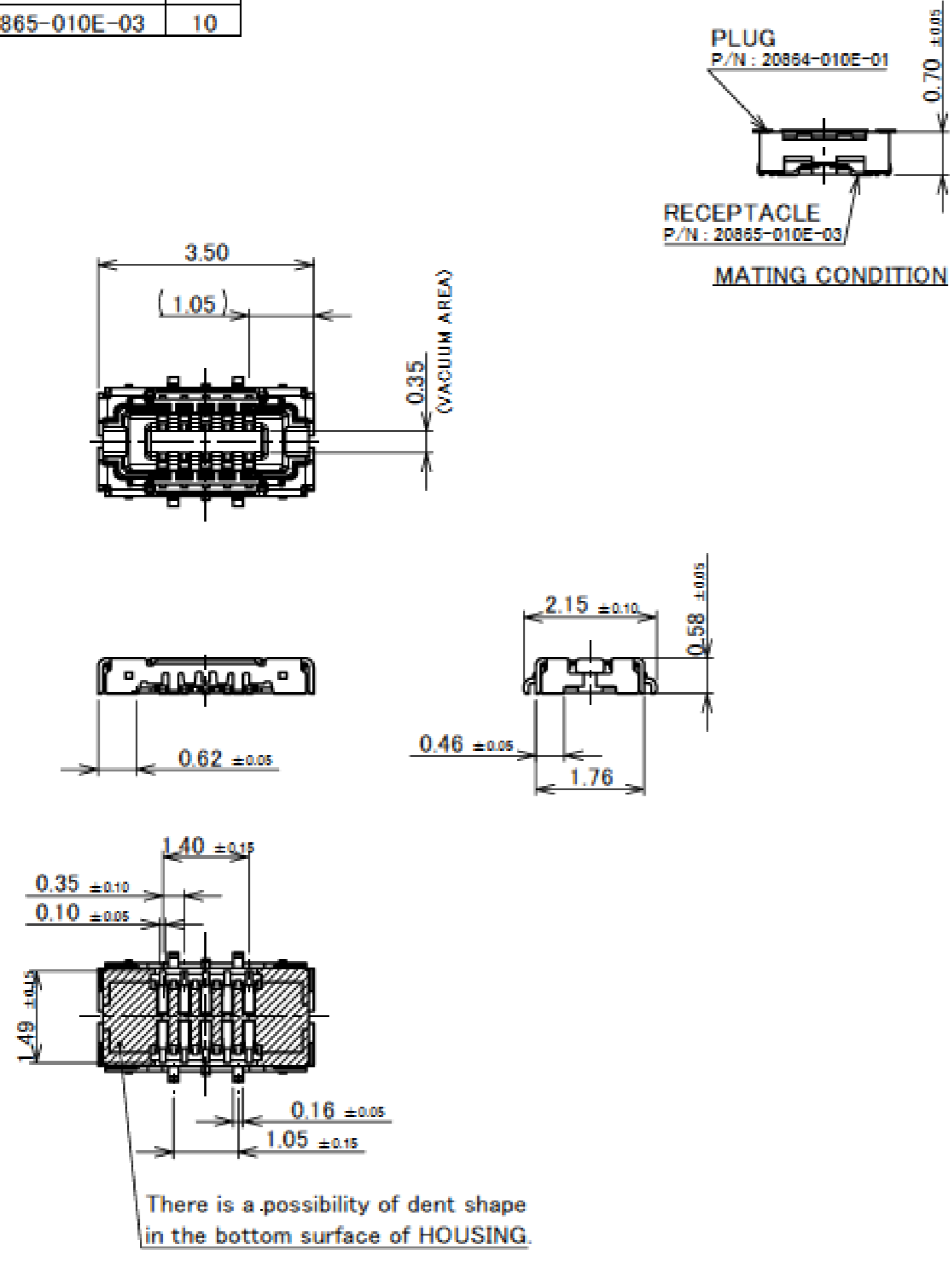

NOTES:  
1. FOOT PRINT PATTERN PROHIBITION AREA :  
SOLDER RESIST MUST BE APPLIED TO THIS HATCHED AREA  
IF SURFACE TRACES ARE ROUNDED.

3	SHELL	COPPER ALLOY	SOLDERING PART Au 0.01 μm MIN. OVER Ni 1.27 μm MIN.
2	CONTACT	COPPER ALLOY	CONTACT PART Au 0.05 μm MIN. OVER Ni 1.27 μm MIN. SOLDERING PART Au 0.01 μm MIN. OVER Ni 1.27 μm MIN.
1	HOUSING	LCP	UL94V-0 BLACK
NO.	DISCRIPTION	MATERIAL	FINISH, REMARKS

Rev.10

Recommended P/N		20865-020E-03
PART NO.	Pos.	
20865-020E-03	20	

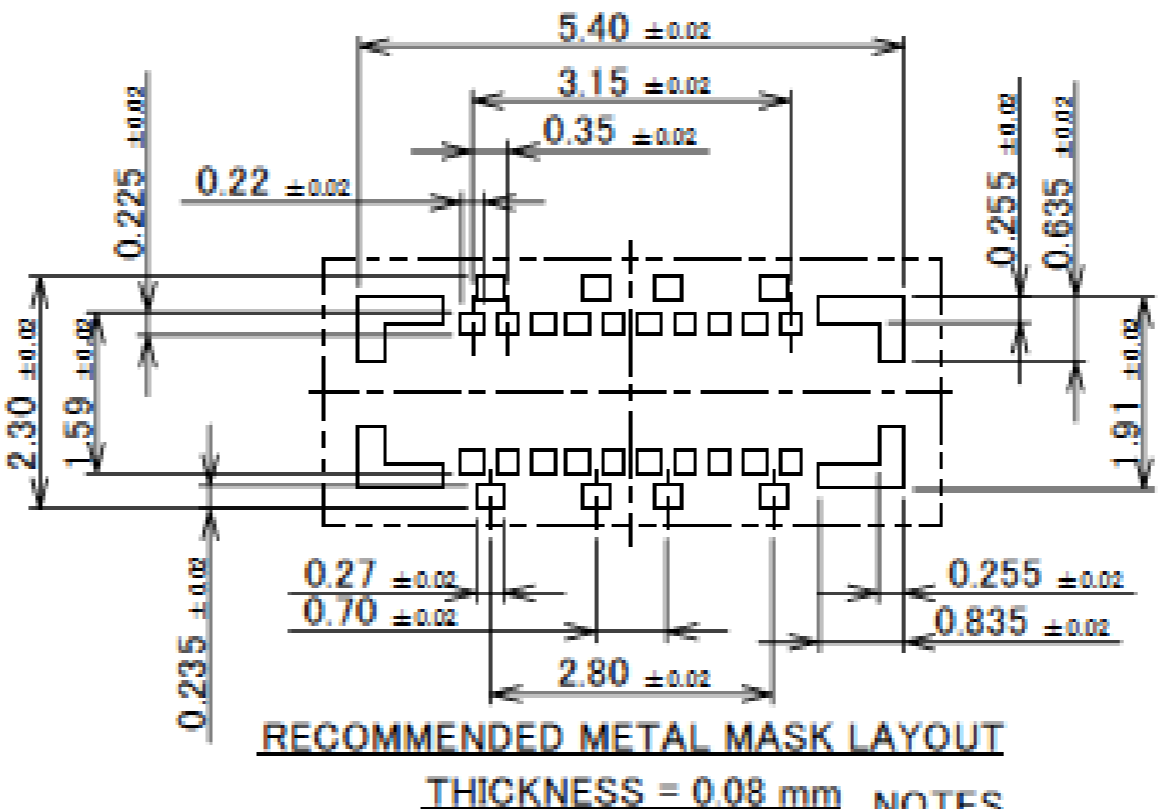
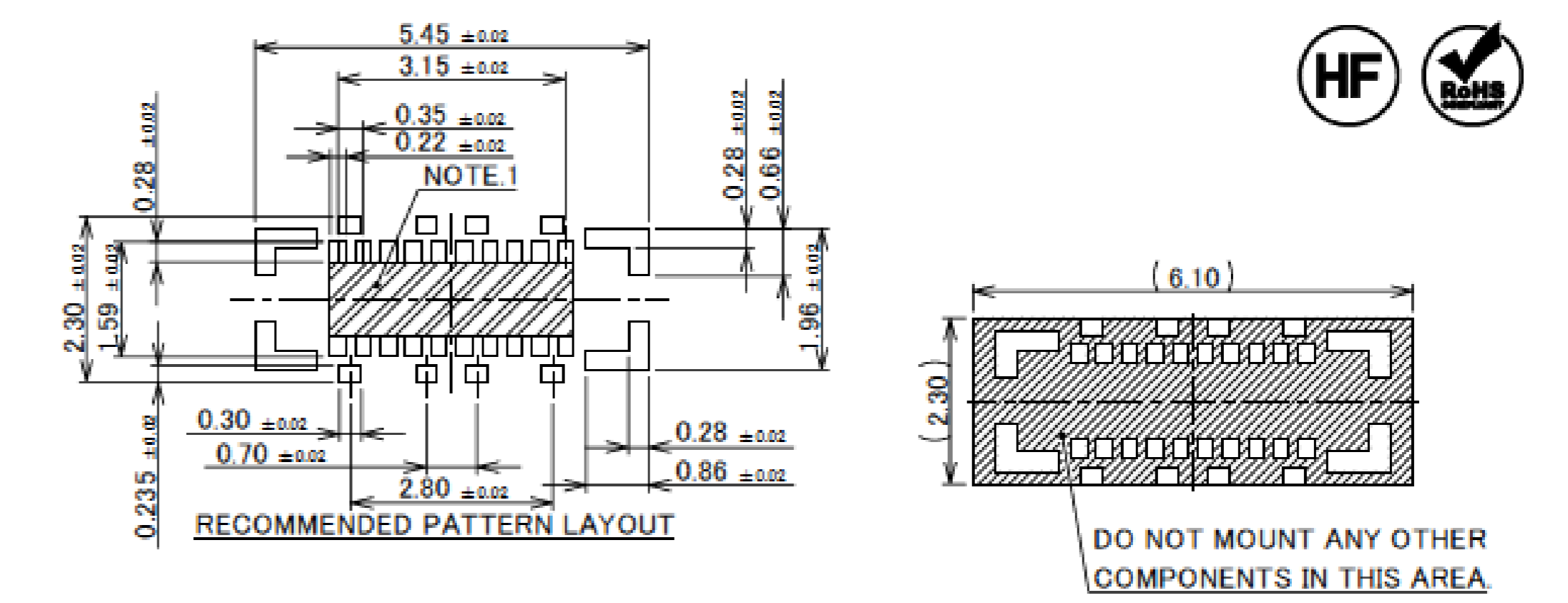
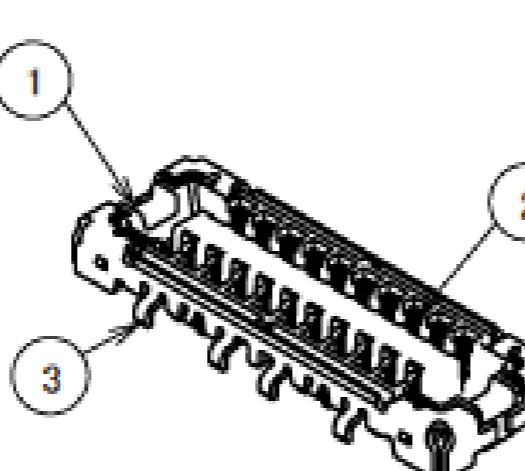
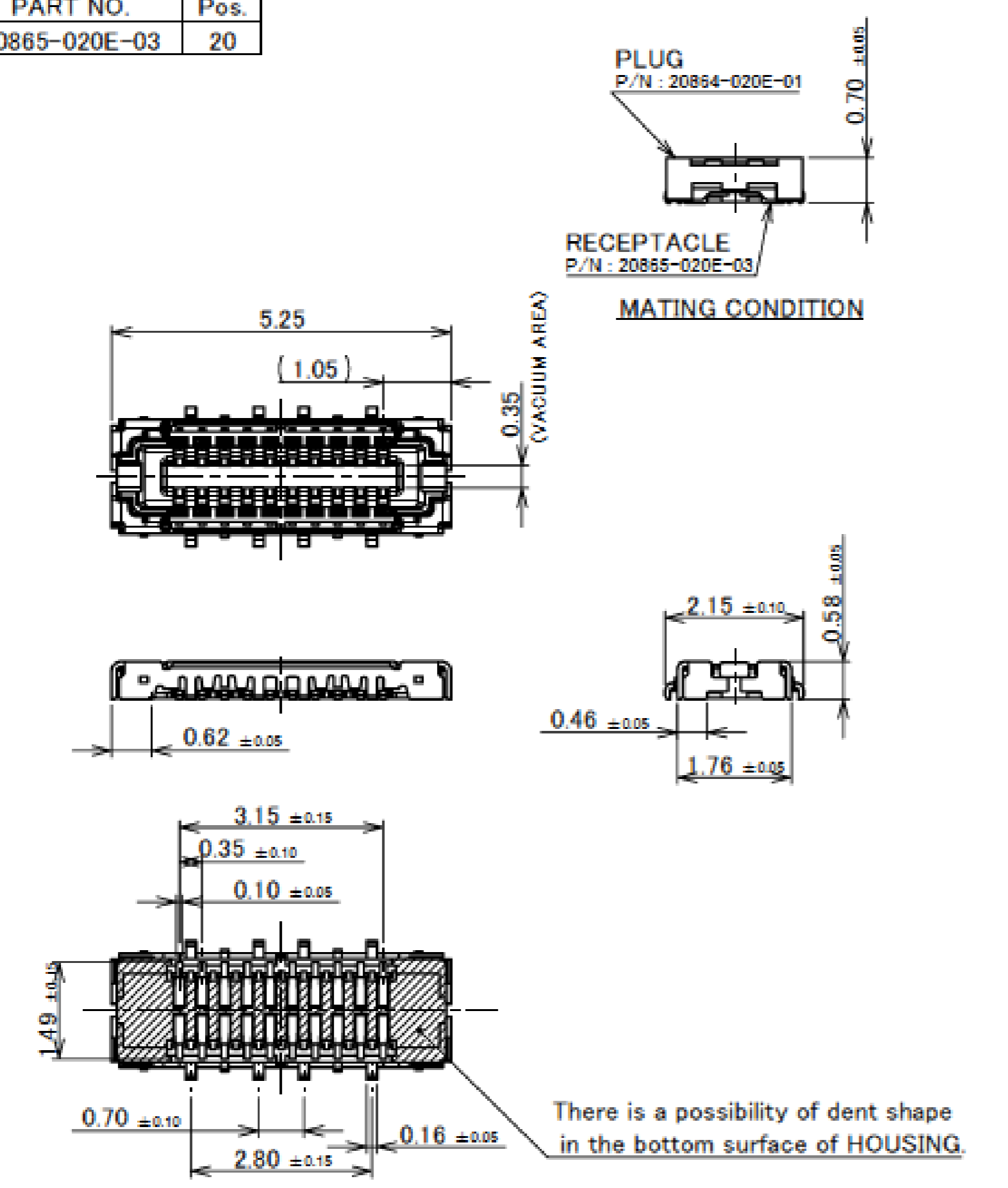

NOTES:  
1. FOOT PRINT PATTERN PROHIBITION AREA :  
SOLDER RESIST MUST BE APPLIED TO THIS HATCHED AREA  
IF SURFACE TRACES ARE ROUNDED.

3	SHELL	COPPER ALLOY	SOLDERING PART Au 0.01 μm MIN. OVER Ni 1.27 μm MIN.
2	CONTACT	COPPER ALLOY	CONTACT PART Au 0.05 μm MIN. OVER Ni 1.27 μm MIN. SOLDERING PART Au 0.01 μm MIN. OVER Ni 1.27 μm MIN.
1	HOUSING	LCP	UL94V-0 BLACK
NO.	DISCRIPTION	MATERIAL	FINISH, REMARKS

Rev.10

# Receptacle Assembly

Recommended P/N	20865-030E-03
PART NO.	Pos.
20865-030E-03	30

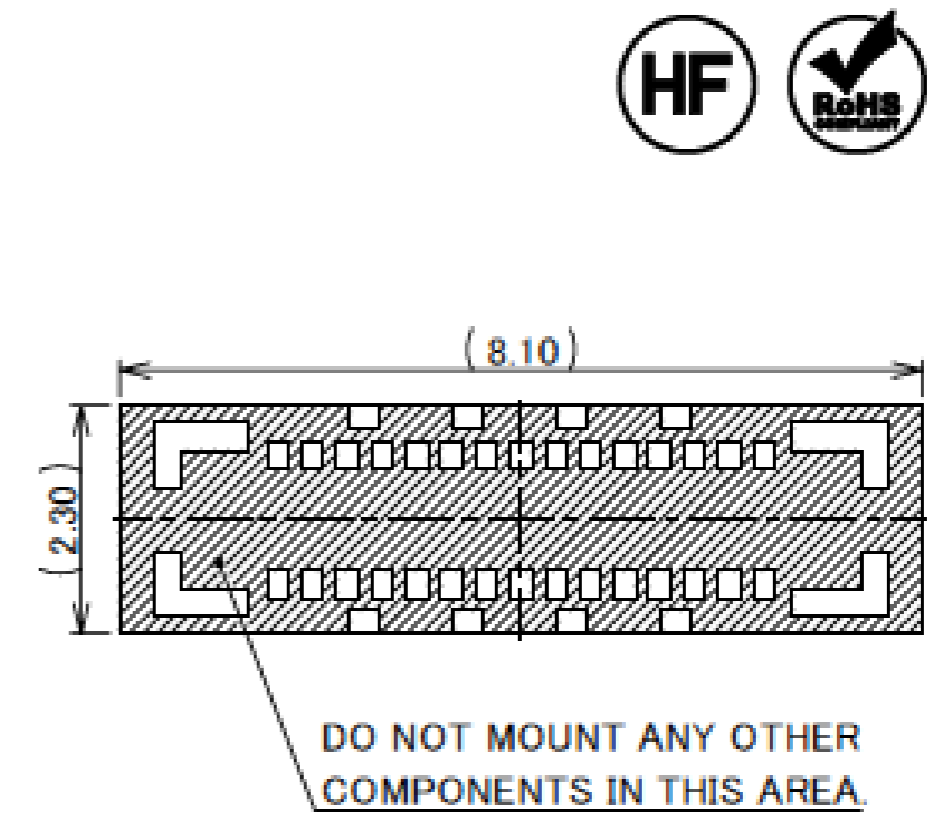
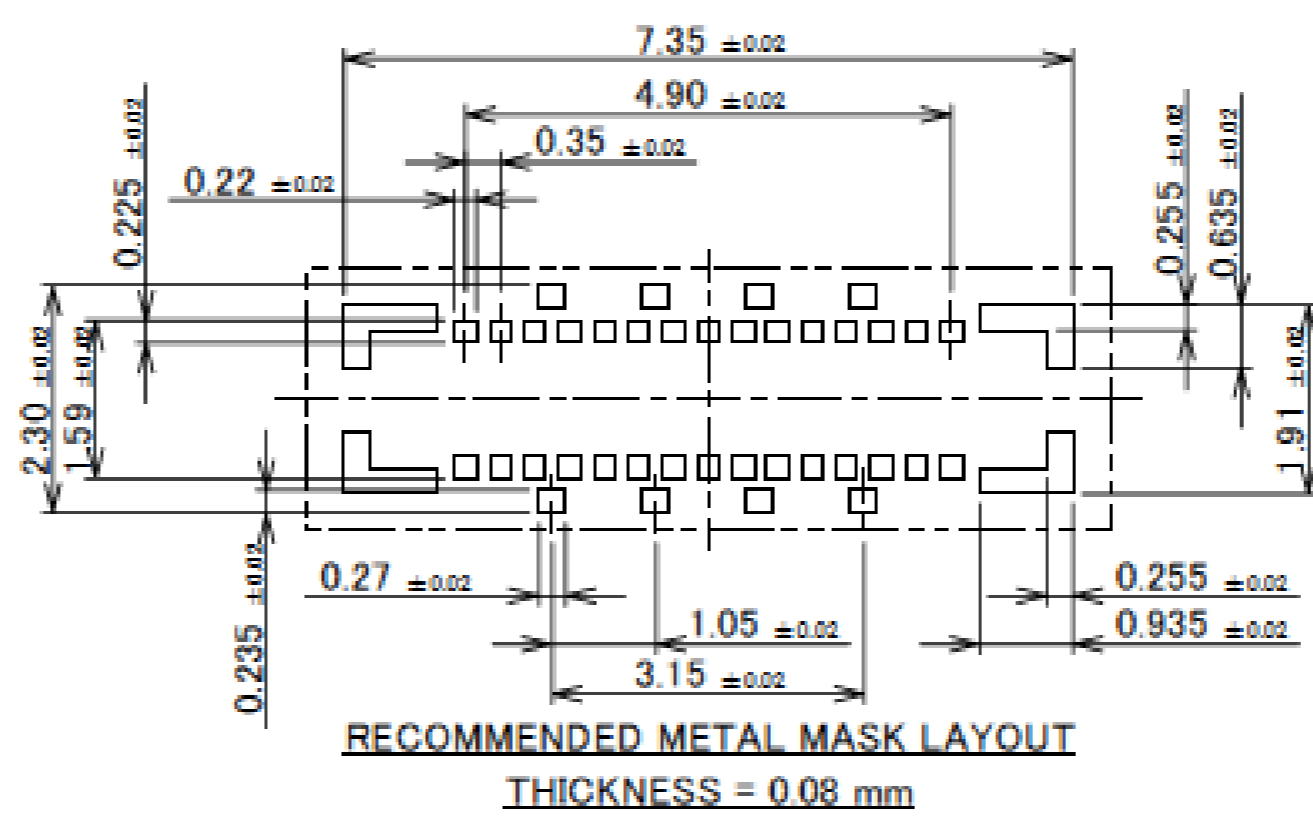
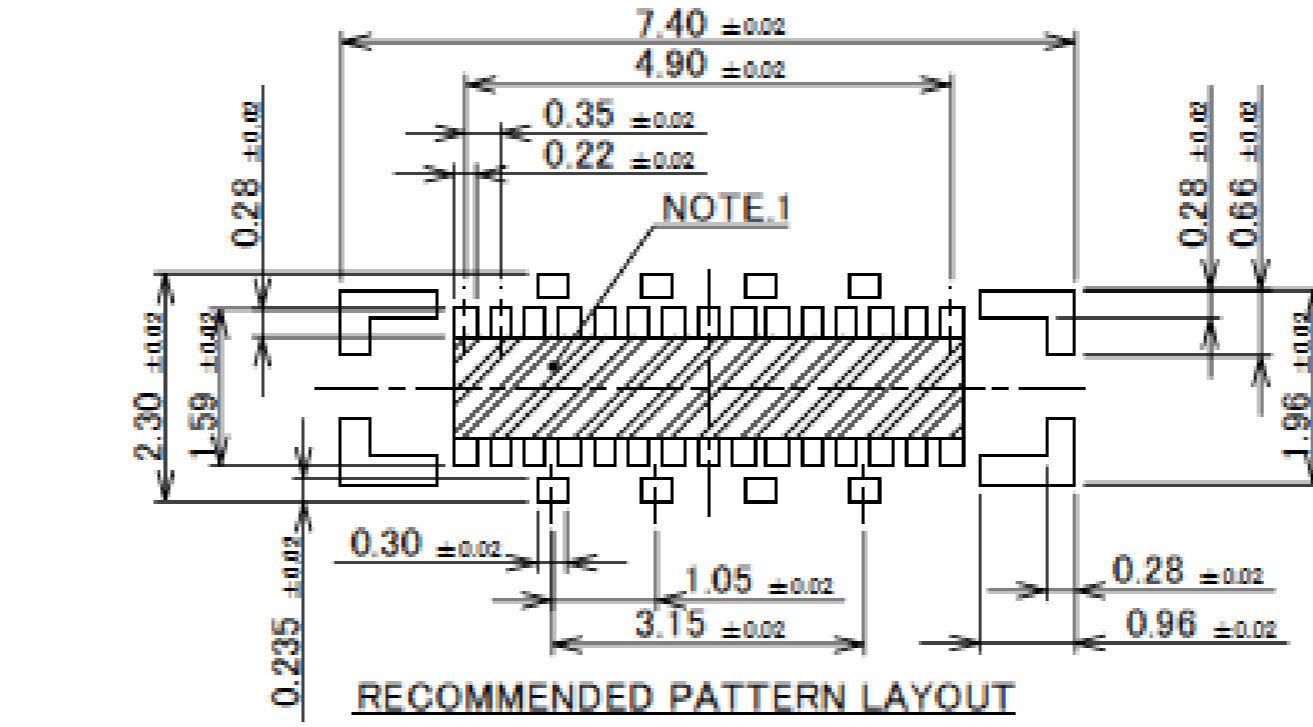
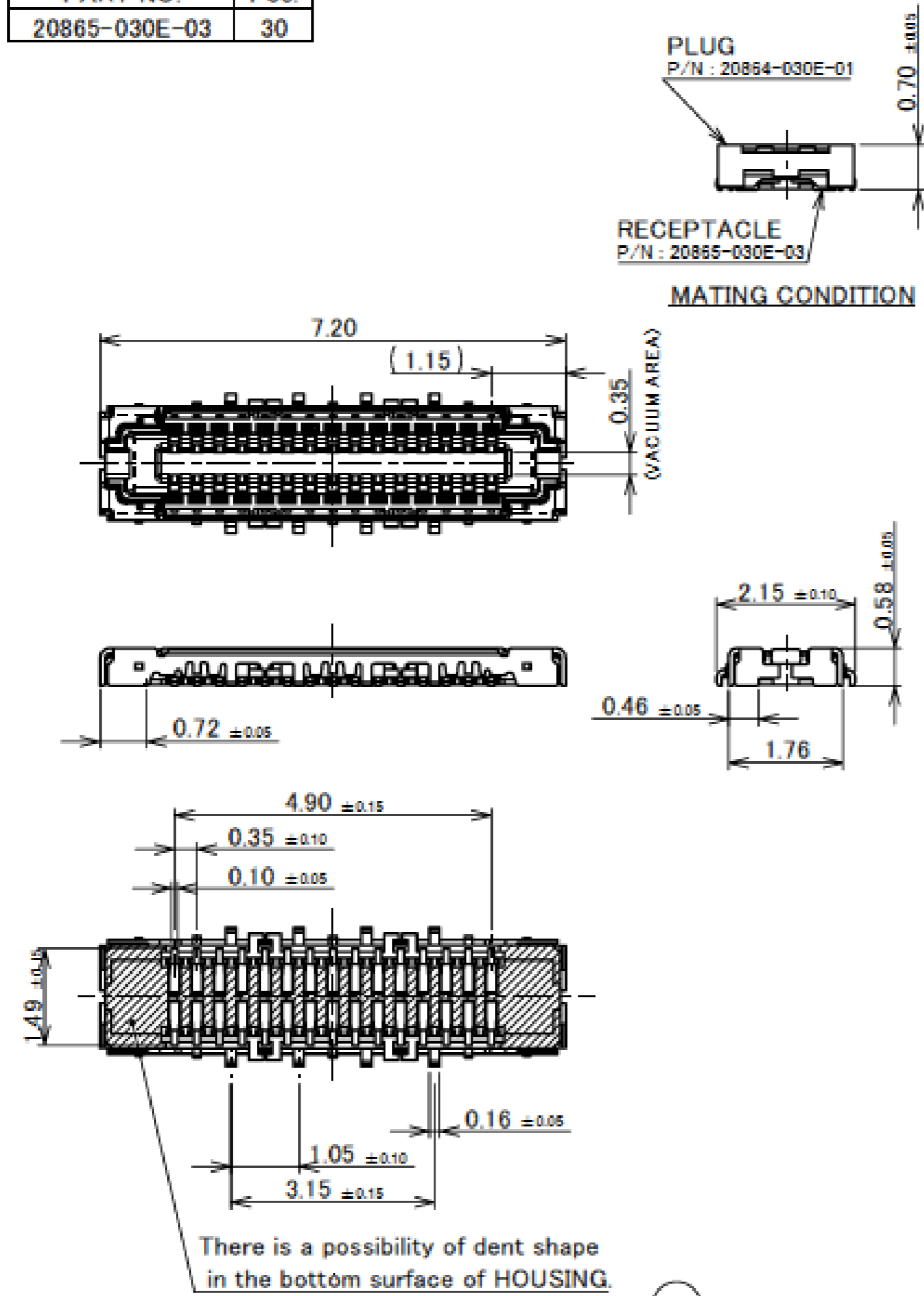

NOTES.  
1. FOOT PRINT PATTERN PROHIBITION AREA :  
SOLDER RESIST MUST BE APPLIED TO THIS HATCHED AREA  
IF SURFACE TRACES ARE ROUNDED.

3	SHELL	COPPER ALLOY	SOLDERING PART Au 0.01 μm MIN. OVER Ni 1.27 μm MIN.
2	CONTACT	COPPER ALLOY	CONTACT PART Au 0.05 μm MIN. OVER Ni 1.27 μm MIN. SOLDERING PART Au 0.01 μm MIN. OVER Ni 1.27 μm MIN.
1	HOUSING	LCP	UL94V-0 BLACK
NO.	DISCRIPTION	MATERIAL	FINISH, REMARKS

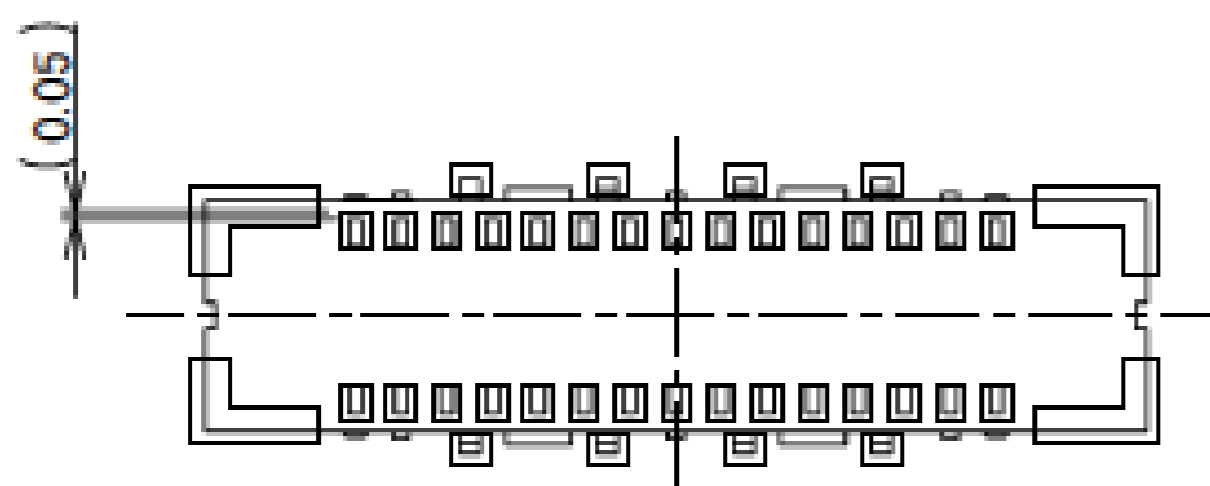
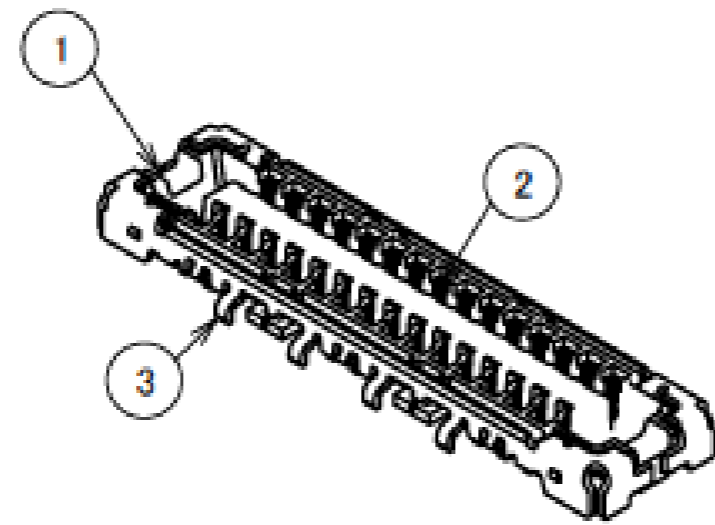

CONNECTOR ON RECOMMENDED FOOTPRINT PATTERN

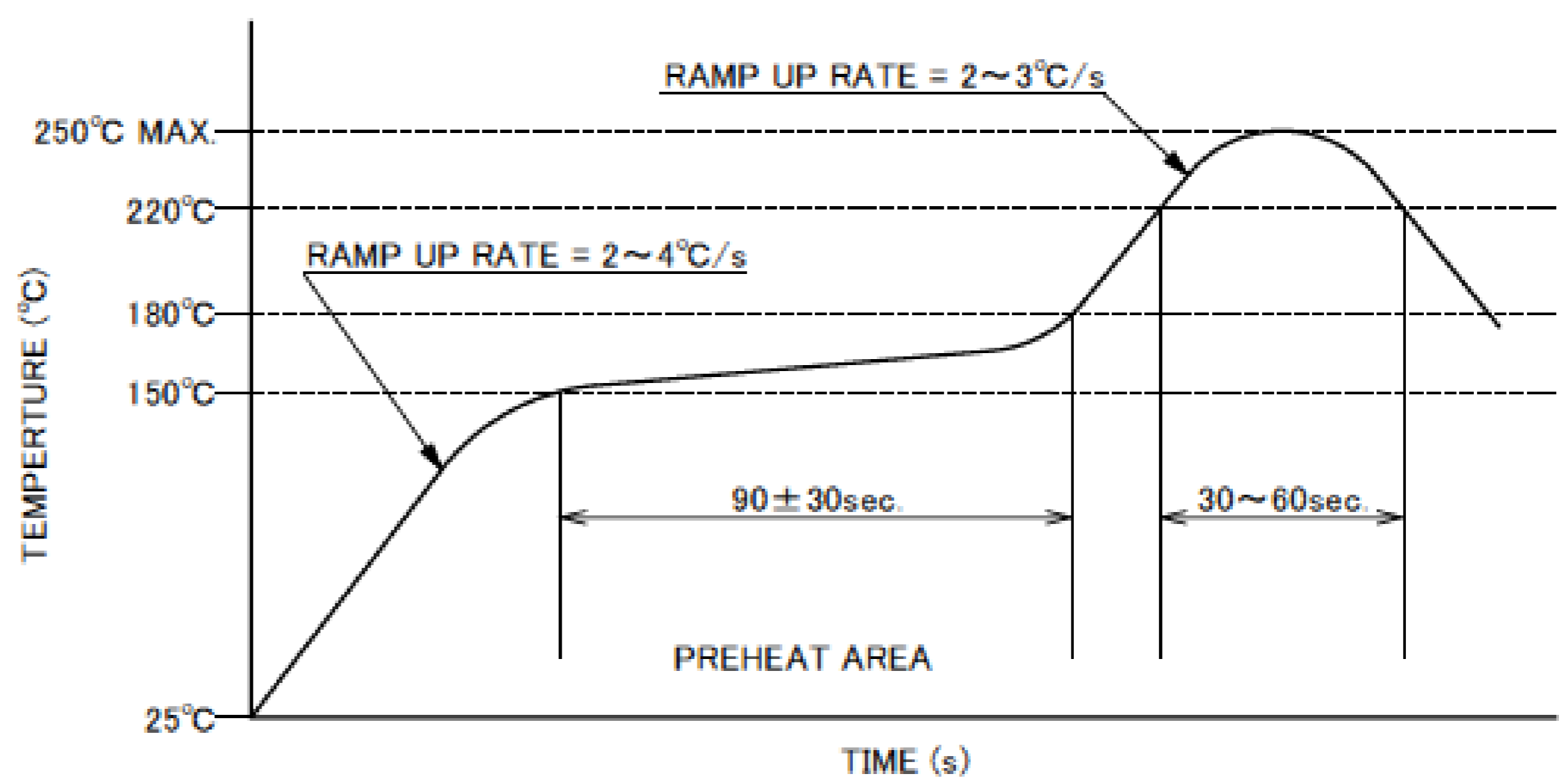

REFLOW TEMPERATURE PROFILE  
SENJU METAL INDUSTRY CO., LTD. : M705-SHF(Sn96.5 Ag3.0 Cu0.5)

# Receptacle Assembly

ITEMS	SPECIFICATION
APPLICABLE CONNECTOR PART No.	20864-0**E-**
RATING VOLTAGE	60V AC(r.m.s) / DC (PER CONTACT PIN)
RATING AMPERAGE (FOR SIGNAL CONTACT)	10P:1.0 A MAX. AC/DC x PIN COUNTS = 10.0 A (TOTAL) 12P AND OVER : 12.0 A AC/DC (TOTAL)
OPERATING TEMPERATURE	233~358K(-40°C~85°C)
OPERATING HUMIDITY	85% MAX.(NON-CONDENDING)
CONTACT RESISTANCE (FOR SIGNAL CONTACT)	INITIAL : 40mohm MAX. / AFTER TEST : $\triangle$ 40mohm MAX.
CONTACT RESISTANCE (FOR GROUND)	INITIAL : 20mohm MAX. / AFTER TEST : $\triangle$ 20mohm MAX.
INSULATION RESISTANCE	INITIAL : 1,000Mohm MIN. / AFTER TEST : 500Mohm MIN.
DIELECTRIC WITHSTANDING VOLTAGE	AC250V 1min
DURABILITY	10 CYCLES
MATING FORCE (INITIAL / AFTER TEST)	INITIAL 2.0N/Pin MAX.
UNMATING FORCE (INITIAL / AFTER TEST)	10 CYCLES 0.15N/Pin MIN.
COPLANARITY	0.08 MAX.
PRODUCT SPECIFICATION	PRS-2607
TEST REPORT	TR-19055
PACKING STANDARD	PST-18023
INSTRUCTION MANUAL	HIM-18019
APPEARANCE CRITERIA No.	QLS-A***

Rev.10

# Custom Products Available

## RF Connector

MHF® series



## Micro-coaxial/Twinax/Discrete Wire Connector

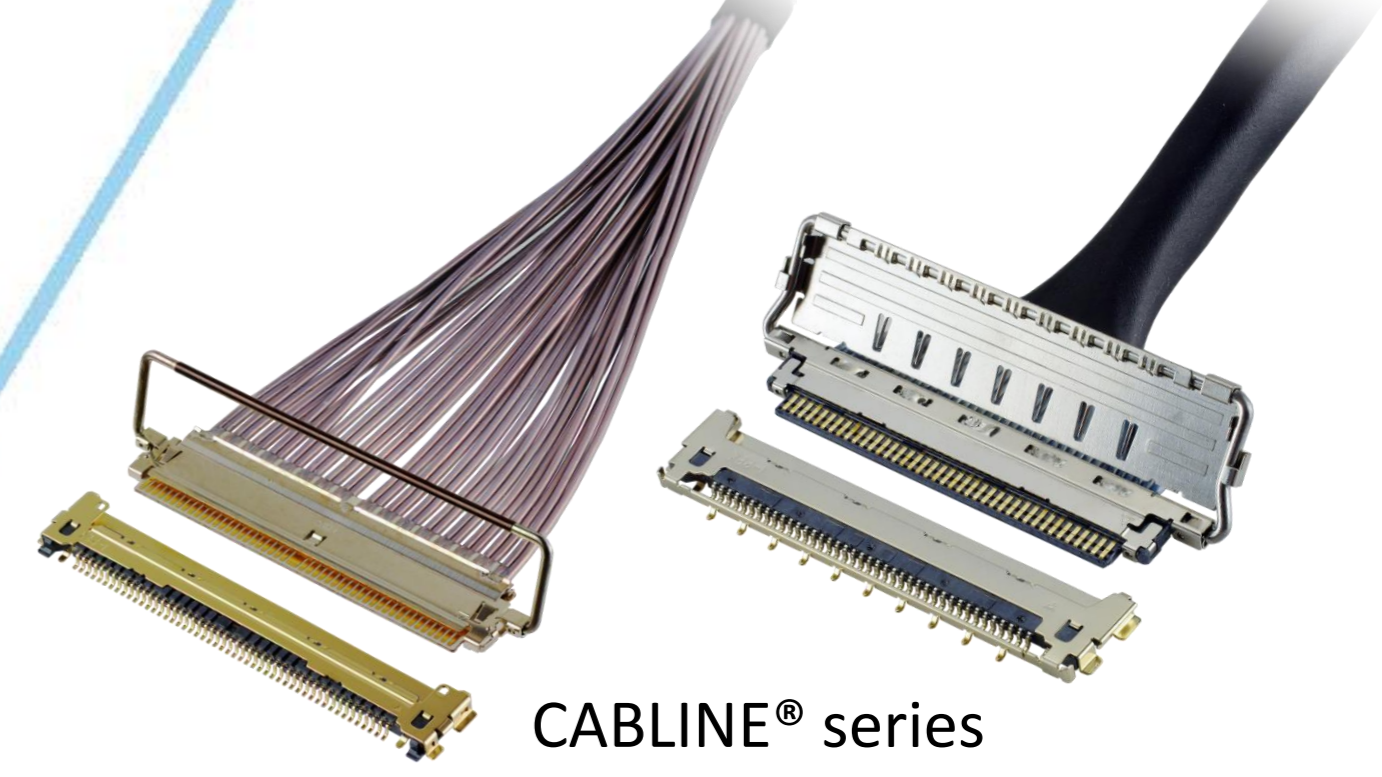

CABLINE® series



## Optical Module

LIGHTPASS® series



NOVASTACK® series

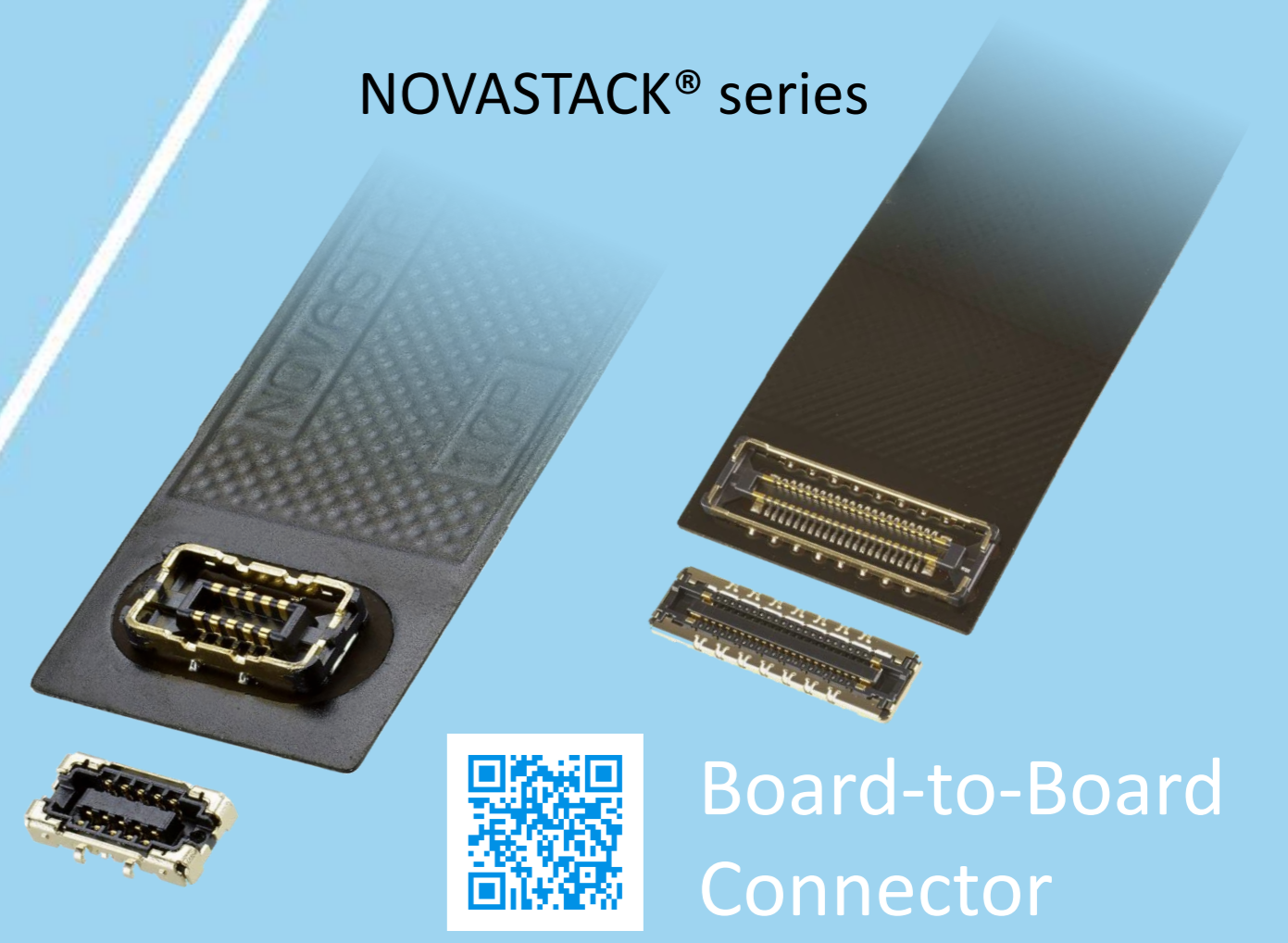

## Board-to-Board Connector



## Power Connector/Terminal

AP series

ISH® series



MINIFLEX® series

EVAFLEX® series



## FPC FFC Connector



Inquiry



MINIDOCK® series

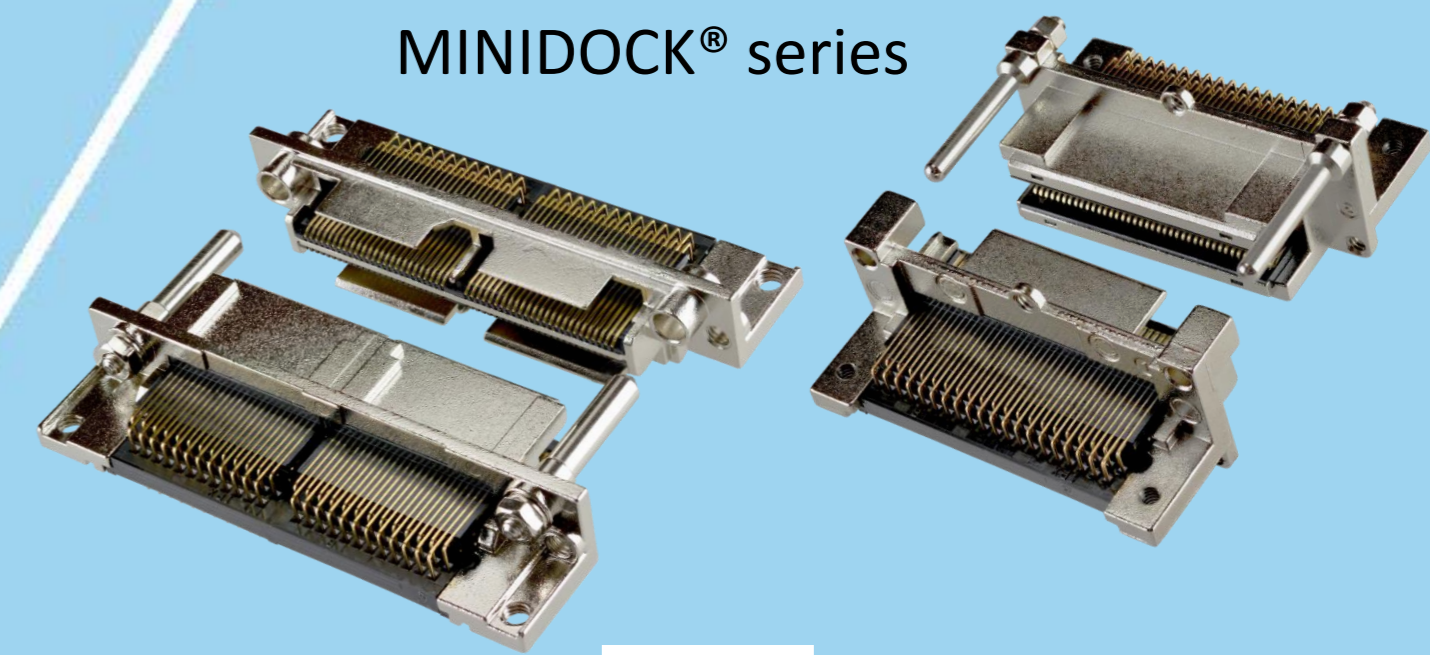

## I/O Connector

I-PEX, MHF, CABLINE, LIGHTPASS, NOVASTACK, ISH, IARPB, MINIFLEX, EVAFLEX, MINIDOCKS and ZenShield are registered trademarks of I-PEX Inc. Please note that the contents in the catalog might be changed without prior notification. I-PEX Inc. assumes no responsibility for any inaccuracies or obligation to update information on these documents. Please be sure to read and understand the latest "Precautions for Use" and "Instruction Manual" before you use our products. We shall not be responsible for any defects, damages or troubles in case you use our products without following the precautions for use. Please feel free to contact our sales representatives when you use our products for any applications that require very high reliability and safety, or that relate to human life (ex. nuclear power control, aerospace, transportation, medical equipment, safety equipment etc.).

Contact your sales representative or more detailed information.

[www.i-pex.com](http://www.i-pex.com)



# I-PEX

© I-PEX Inc. 2024  
All rights reserved