

1. Product profile

1.1 General description

600 W GaN packaged asymmetric Doherty power transistor for base station applications at frequencies from 700 MHz to 1000 MHz.

Table 1. Typical performance

Typical RF performance at $T_{case} = 25\text{ }^{\circ}\text{C}$ in a Doherty application demo circuit, unless otherwise specified.

Test signal	I_{Dq} (mA)	V_{DS} (V)	$V_{GS(amp)peak}$ (V)	$P_{L(AV)}$ (dBm)	G_p (dB)	η_D (%)	ACPR (dBc)	$P_{L(5dB)}$ (dBm)
f = 791 MHz to 821 MHz								
1-carrier W-CDMA [1]	100	48	-5.7	49.4	18.7	62.4	-24.4	-
pulsed CW [2]	100	48	-5.7	-	-	-	-	58.0
f = 869 MHz to 960 MHz								
1-carrier W-CDMA [1]	180	50	-5.5	50.2	18.0	59.7	-23.9	-
pulsed CW [2]	180	50	-5.5	-	-	-	-	58.1

[1] Test signal: 1-carrier W-CDMA; 3GPP test model 1; 64 DPCH; PAR = 10.5 dB at 0.01 % probability on CCDF.

[2] Test signal: pulsed CW; $t_p = 30\text{ }\mu\text{s}$; $\delta = 35\text{ }\%$.

1.2 Features and benefits

- Excellent digital pre-distortion capability
- High efficiency
- Designed for broadband operation
- Lower output capacitance for improved performance in Doherty applications
- For RoHS compliance see the product details on the Ampleon website

1.3 Applications

- RF power amplifier for base stations and multi carrier applications in the 700 MHz to 1000 MHz frequency range

2. Pinning information

Table 2. Pinning

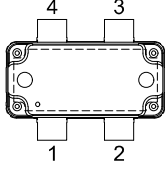
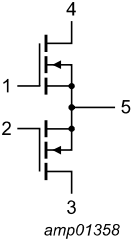
Pin	Description	Simplified outline	Graphic symbol
1	gate1 (main)		
2	gate2 (peak)		
3	drain2 (peak)		
4	drain1 (main)		
5	source [1]		

[1] Connected to flange.

3. Ordering information

Table 3. Ordering information

Package name	Orderable part number	12NC	Packing description	Min. orderable quantity (pieces)
OMP-780-4F-1	C4H10P600AY	9349 605 58518	TR13; 100-fold; 44 mm; dry pack	100

4. Limiting values

Table 4. Limiting values

In accordance with the Absolute Maximum Rating System (IEC 60134).

Symbol	Parameter	Conditions	Min	Max	Unit
V_{DD}	supply voltage	operating	-	52	V
V_{DS}	drain-source voltage	$V_{GS} = -8$ V	-	150	V
$V_{GS(amp)main}$	main amplifier gate-source voltage		-15	+2	V
$V_{GS(amp)peak}$	peak amplifier gate-source voltage		-15	+2	V
$I_{GF(amp)main}$	main amplifier forward gate current		-	4.8	mA
$I_{GF(amp)peak}$	peak amplifier forward gate current		-	7.2	mA
T_{stg}	storage temperature		-65	+150	°C
T_{ch}	active die channel temperature		[1]	275	°C
T_{case}	case temperature	operating	[1]	+140	°C

[1] Continuous use at maximum temperature will affect the reliability, for details refer to the online MTF calculator.

5. Thermal characteristics

Table 5. Thermal characteristics

Symbol	Parameter	Conditions	Typ	Unit
$R_{th(s-c)(IR)}$ [1]	thermal resistance from active die surface to case by Infrared measurement	$T_{case} = 100\text{ °C}$; $P_{dis(main)} = 48\text{ W}$; $P_{dis(peak)} = 15\text{ W}$	1.26	K/W
$R_{th(ch-c)(FEA)}$ [2]	thermal resistance from active die channel to case by Finite Element Analysis	$T_{case} = 100\text{ °C}$; $P_{dis(main)} = 48\text{ W}$; $P_{dis(peak)} = 15\text{ W}$	1.53	K/W

[1] Infrared (IR) thermal values are for reference only and cannot be used to determine performance or reliability.

[2] Finite Element Analysis (FEA) thermal values have been used for the online MTF calculator.

6. Characteristics

Table 6. DC characteristics

$T_j = 25\text{ °C}$ unless otherwise specified.

Symbol	Parameter	Conditions	Min	Typ	Max	Unit
Main device						
$V_{GS(th)}$	gate-source threshold voltage	$V_{DS} = 10\text{ V}$; $I_D = 27\text{ mA}$	-3.15	-2.55	-1.95	V
V_{GSq}	gate-source quiescent voltage	$V_{DS} = 50\text{ V}$; $I_D = 540\text{ mA}$	-3.0	-2.4	-1.8	V
$I_{D(leak)}$	drain leakage current	$V_{GS} = -10\text{ V}$; $V_{DS} = 50\text{ V}$	-	-	6.534	mA
I_{GSS}	gate leakage current	$V_{GS} = -8\text{ V}$; $V_{DS} = 0\text{ V}$	-	-	1.307	mA
Peak device						
$V_{GS(th)}$	gate-source threshold voltage	$V_{DS} = 10\text{ V}$; $I_D = 45\text{ mA}$	-3.13	-2.53	-1.93	V
V_{GSq}	gate-source quiescent voltage	$V_{DS} = 50\text{ V}$; $I_D = 900\text{ mA}$	-3.0	-2.4	-1.8	V
$I_{D(leak)}$	drain leakage current	$V_{GS} = -10\text{ V}$; $V_{DS} = 50\text{ V}$	-	-	10.89	mA
I_{GSS}	gate leakage current	$V_{GS} = -8\text{ V}$; $V_{DS} = 0\text{ V}$	-	-	2.178	mA

Table 7. RF characteristics

Test signal: 1-carrier W-CDMA; PAR = 7.2 dB at 0.01 % probability on the CCDF; 3GPP test model 1; 64 DPCH; $f_1 = 793.5\text{ MHz}$; $f_2 = 818.5\text{ MHz}$; RF performance at $V_{DS} = 48\text{ V}$; $I_{Dq} = 200\text{ mA}$; $V_{GS(amp)peak} = -2.7\text{ V}$ (typical); $T_{case} = 25\text{ °C}$; unless otherwise specified; in a Doherty production RF test circuit.

Symbol	Parameter	Conditions	Min	Typ	Max	Unit
G_p	power gain	$P_{L(AV)} = 83\text{ W}$	17.0	18.2	-	dB
η_D	drain efficiency	$P_{L(AV)} = 83\text{ W}$	56	61	-	%
RL_{in}	input return loss	$P_{L(AV)} = 83\text{ W}$	-	-16.5	-8	dB
ACPR	adjacent channel power ratio	$P_{L(AV)} = 83\text{ W}$	-	-24.4	-18	dBc

Table 8. RF characteristics

Test signal: pulsed CW; $t_p = 100\text{ }\mu\text{s}$; $\delta = 10\%$; $f_1 = 791\text{ MHz}$; $f_2 = 821\text{ MHz}$; RF performance at $V_{DS} = 48\text{ V}$; $I_{Dq} = 200\text{ mA}$; $V_{GS(amp)peak} = -2.7\text{ V}$ (typical); $T_{case} = 25\text{ °C}$; unless otherwise specified; in a Doherty production RF test circuit.

Symbol	Parameter	Conditions	Min	Typ	Max	Unit
$P_{L(4dB)}$	output power at 4 dB gain compression	maximum 4 dB compression	450	570	-	W

7. Test information

7.1 Ruggedness in Doherty operation

7.1.1 At f = 791 MHz; tested on the Doherty application demo board

The C4H10P600A is capable of withstanding a load mismatch corresponding to VSWR = 10 : 1 through all phases under the following conditions: $V_{DS} = 50\text{ V}$; $P_L = 600\text{ W}$ pulsed CW; $f = 791\text{ MHz}$ on C4H10P600A correlation board.

7.2 Impedance information

Table 9. Typical impedance of maximum power and drain efficiency

Measured load-pull data (main device); all data measured on a non-harmonic impedance optimized load-pull fixture; $I_{DQ} = 300\text{ mA}$; $V_{DS} = 48\text{ V}$; test signal: pulsed CW; $t_p = 100\text{ }\mu\text{s}$; $\delta = 10\%$; typical values unless otherwise specified.

f	Z _S [1]	Z _L [1]	P _L [2]		η _D [2]	G _p [2]
(MHz)	(Ω)	(Ω)	(dBm)	(W)	(%)	(dB)
Maximum power load						
791	0.9 – j3.0	3.6 – j0.6	54.9	310	66.8	18.5
803	0.9 – j3.2	3.7 – j0.5	54.9	310	67.5	18.5
821	1.0 – j3.3	3.6 – j0.6	54.8	302	66.1	18.5
Maximum drain efficiency load						
791	0.9 – j3.0	7.3 + j2.3	53.0	200	73.4	20.7
803	0.9 – j3.2	5.8 + j1.1	53.9	245	73.5	20.1
821	1.0 – j3.3	6.7 + j2.2	53.0	200	72.4	20.5

[1] Z_S and Z_L defined in [Figure 1](#).

[2] At 3 dB gain compression.

Table 10. Typical impedance of maximum power and drain efficiency

Measured load-pull data (peak device); all data measured on a harmonic impedance optimized load-pull fixture; $I_{DQ} = 470\text{ mA}$; $V_{DS} = 48\text{ V}$; test signal: pulsed CW; $t_p = 100\text{ }\mu\text{s}$; $\delta = 10\%$; typical values unless otherwise specified.

f	Z _S [1]	Z _L [1]	P _L [2]		η _D [2]	G _p [2]
(MHz)	(Ω)	(Ω)	(dBm)	(W)	(%)	(dB)
Maximum power load						
791	1.1 – j3.7	2.6 – j0.8	56.7	468	71.4	18.2
803	1.2 – j3.9	2.6 – j0.8	56.7	468	72.3	18.2
821	1.3 – j4.0	2.5 – j1.2	56.6	457	66.8	17.7
Maximum drain efficiency load						
791	1.1 – j3.7	2.9 + j0.6	55.7	371	76.7	19.6
803	1.2 – j3.9	2.9 + j0.7	55.7	371	77.8	19.6
821	1.3 – j4.0	2.8 + j0.6	55.6	363	75.4	19.4

[1] Z_S and Z_L defined in [Figure 1](#).

[2] At 3 dB gain compression.

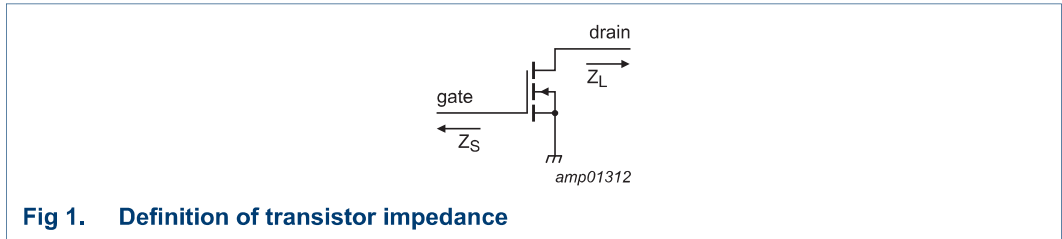

7.3 Test circuit

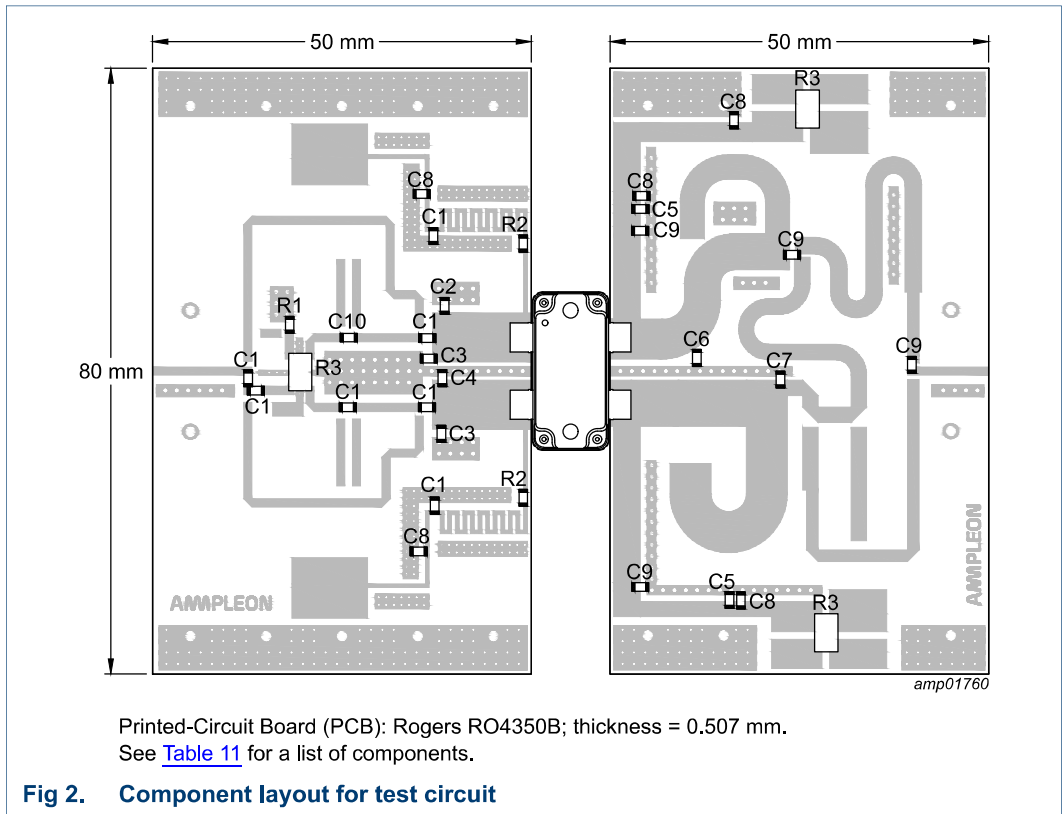

Table 11. List of components
See [Figure 2](#) for component layout.

Component	Description	Value	Remarks
C1	multilayer ceramic chip capacitor	180 pF	ATC 600F
C2	multilayer ceramic chip capacitor	9.1 pF	ATC 600F
C3	multilayer ceramic chip capacitor	10 pF	ATC 600F
C4	multilayer ceramic chip capacitor	11 pF	ATC 600F
C5	multilayer ceramic chip capacitor	1000 pF	ATC 800B
C6	multilayer ceramic chip capacitor	1 pF	ATC 800B
C7	multilayer ceramic chip capacitor	1.5 pF	ATC 800B
C8	electrolytic capacitor	10 μ F, 100 V	
C9	multilayer ceramic chip capacitor	180 pF	ATC 800B
C10	multilayer ceramic chip capacitor	36 pF	ATC 600F

Table 11. List of components ...continued
See [Figure 2](#) for component layout.

Component	Description	Value	Remarks
X10	hybrid coupler	2 dB	RJ2
R1	resistor	510 Ω	
R2	resistor	9.1 Ω	
R3	current sense resistor	10 mΩ	LVK25(1224)

7.4 Graphical data

All the data are measured on the Doherty RF test circuit.

7.4.1 Pulsed CW

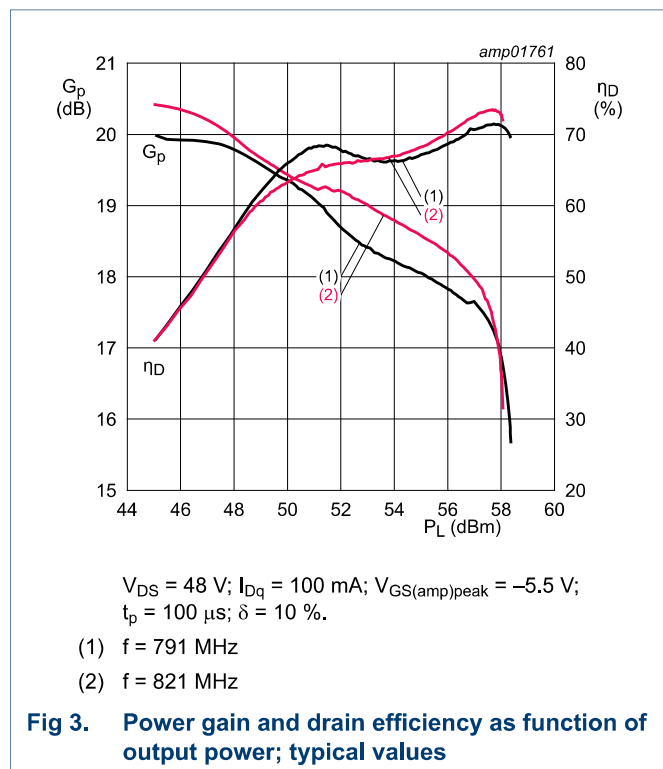

7.4.2 1-Carrier W-CDMA

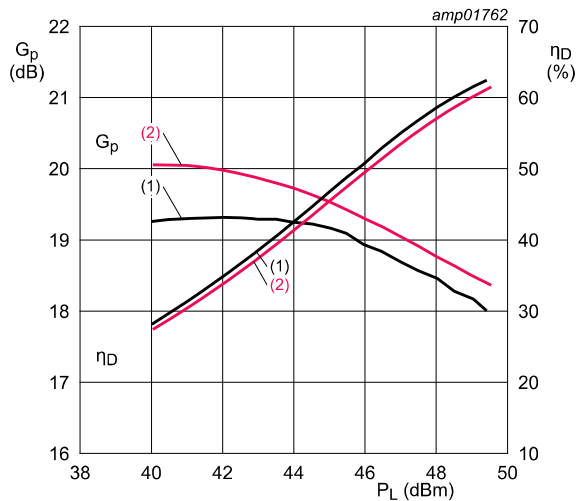

$V_{DS} = 48$ V; $I_{Dq} = 100$ mA; $V_{GS(amp)peak} = -5.5$ V.

- (1) $f = 791$ MHz
- (2) $f = 821$ MHz

Fig 4. Power gain and drain efficiency as function of average output power; typical values

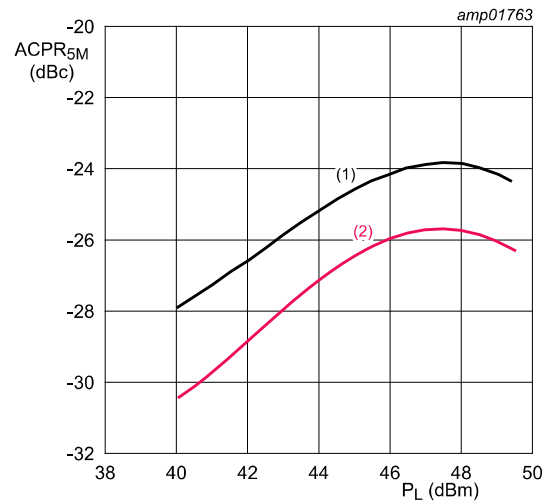

$V_{DS} = 48$ V; $I_{Dq} = 100$ mA; $V_{GS(amp)peak} = -5.5$ V.

- (1) $f = 791$ MHz
- (2) $f = 821$ MHz

Fig 5. Adjacent channel power ratio (5 MHz) as a function of output power; typical values

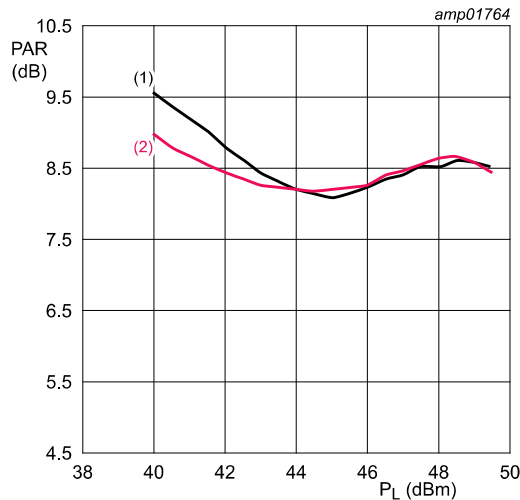

$V_{DS} = 48$ V; $I_{Dq} = 100$ mA; $V_{GS(amp)peak} = -5.5$ V.

- (1) $f = 791$ MHz
- (2) $f = 821$ MHz

Fig 6. Peak-to-average power ratio as a function of output power; typical values

7.4.3 2-Tone VBW

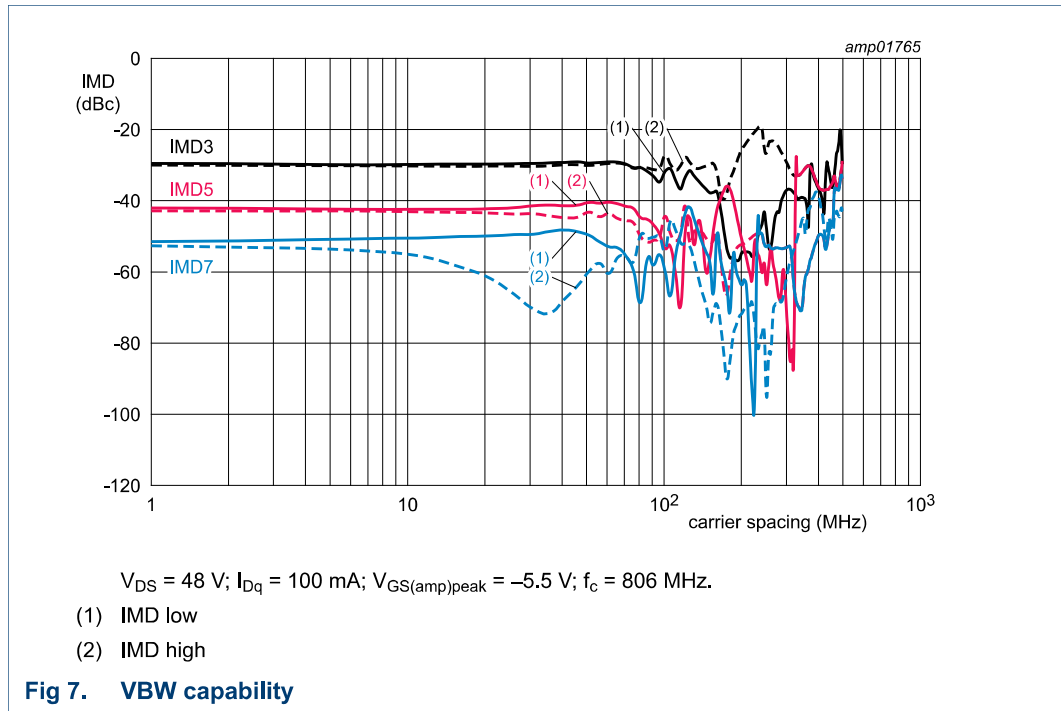

8. Package outline

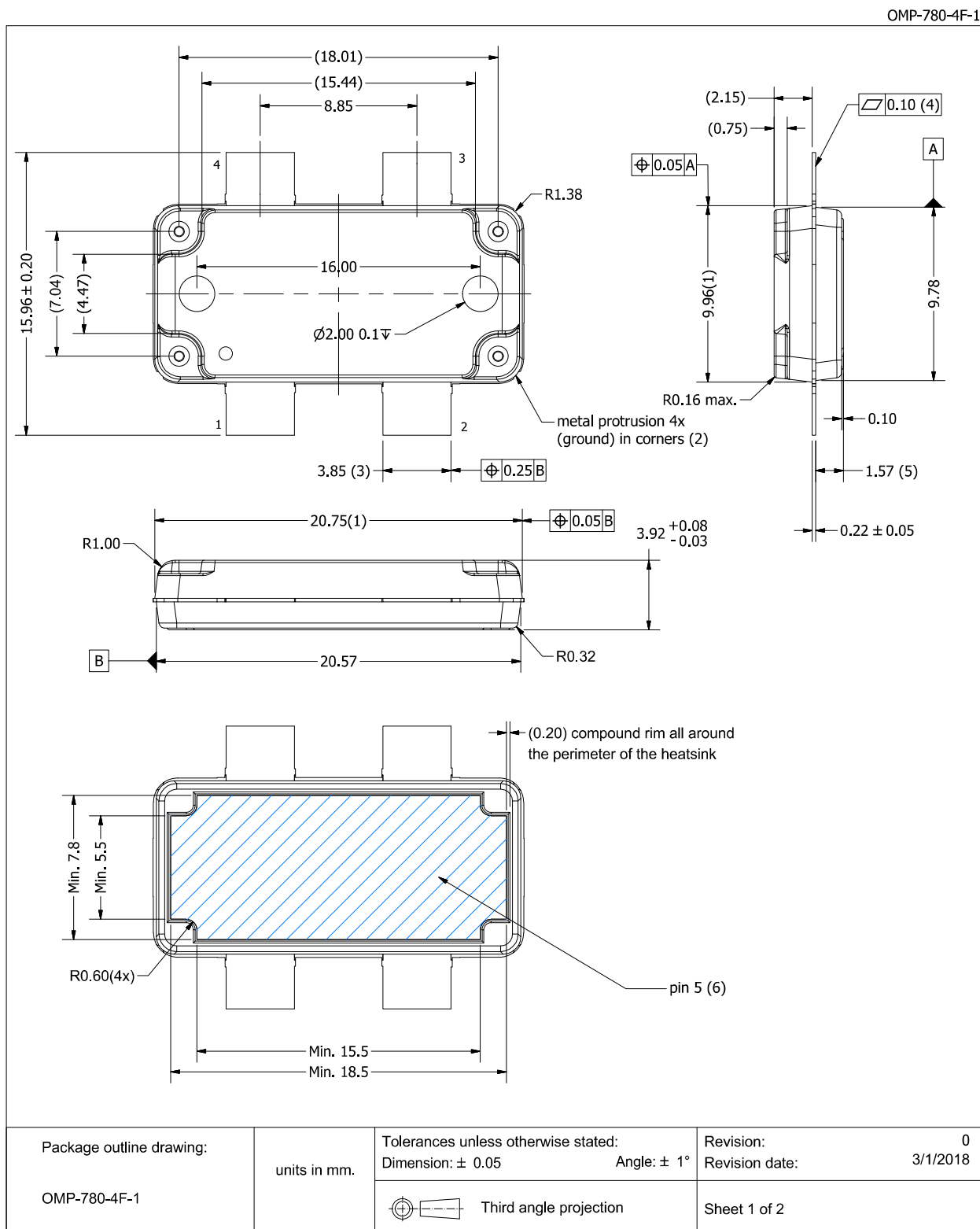
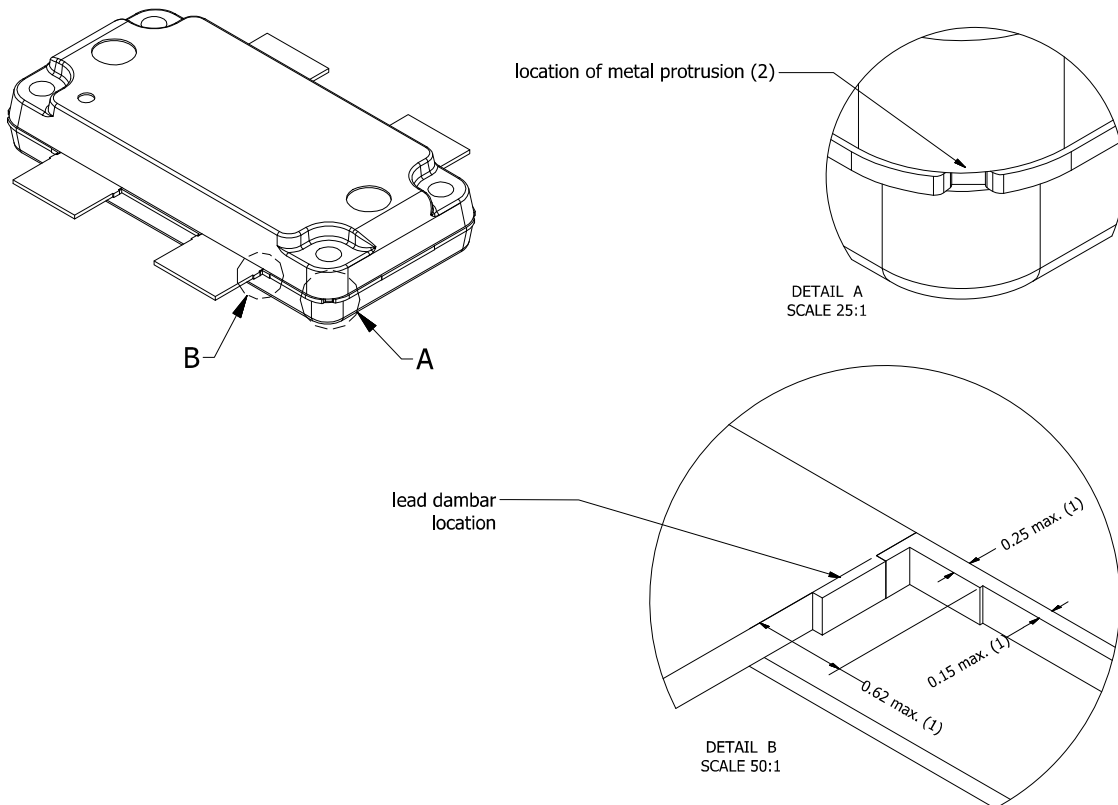

Fig 8. Package outline OMP-780-4F-1 (sheet 1 of 2)

OMP-780-4F-1

Drawing Notes	
Items	Description
(1)	Dimensions are excluding mold protrusion. All areas located adjacent to the leads have a maximum mold protrusion of 0.25 mm (per side) and max. 0.62 mm in length. At all other areas the mold protrusion is maximum 0.15 mm per side. See also detail B.
(2)	The metal protrusion (tie bars) in the corner will not stick out of the molding compound protrusions (detail A).
(3)	The lead dambar (metal) protrusions are not included. Add 0.14 mm max to the total lead dimension at the dambar location.
(4)	The lead coplanarity over all leads is 0.1 mm maximum.
(5)	Dimension is measured 0.5 mm from the edge of the top package body.
(6)	The hatched area indicates the exposed metal heatsink.
(7)	The leads and exposed heatsink are plated with matte Tin (Sn).



Package outline drawing:	units in mm.	Tolerances unless otherwise stated: Dimension: ± 0.05 Angle: $\pm 1^\circ$	Revision: 0 Revision date: 3/1/2018
OMP-780-4F-1		Third angle projection	Sheet 2 of 2

Fig 9. Package outline OMP-780-4F-1 (sheet 2 of 2)

9. Handling information

CAUTION



This device is sensitive to ElectroStatic Discharge (ESD). Observe precautions for handling electrostatic sensitive devices.
Such precautions are described in the *ANSI/ESD S20.20*, *IEC/ST 61340-5*, *JESD625-A* or equivalent standards.

Table 12. ESD sensitivity

ESD model	Class
Charged Device Model (CDM); According to ANSI/ESDA/JEDEC standard JS-002	C3 [1]
Human Body Model (HBM); According to ANSI/ESDA/JEDEC standard JS-001	1B [2]

- [1] CDM classification C3 is granted to any part that passes after exposure to an ESD pulse of 1000 V.
- [2] HBM classification 1B is granted to any part that passes after exposure to an ESD pulse of 500 V.

10. Abbreviations

Table 13. Abbreviations

Acronym	Description
3GPP	3rd Generation Partnership Project
CCDF	Complementary Cumulative Distribution Function
CW	Continuous Wave
DPCH	Dedicated Physical CHannel
GaN	Gallium Nitride
MTF	Median Time to Failure
PAR	Peak-to-Average Ratio
RoHS	Restriction of Hazardous Substances
VBW	Video BandWidth
VSWR	Voltage Standing Wave Ratio
W-CDMA	Wideband Code Division Multiple Access

11. Revision history

Table 14. Revision history

Document ID	Release date	Data sheet status	Change notice	Supersedes
C4H10P600A v.1	20220513	Product data sheet	-	-

12. Legal information

12.1 Data sheet status

Document status ^{[1][2]}	Product status ^[3]	Definition
Objective [short] data sheet	Development	This document contains data from the objective specification for product development.
Preliminary [short] data sheet	Qualification	This document contains data from the preliminary specification.
Product [short] data sheet	Production	This document contains the product specification.

[1] Please consult the most recently issued document before initiating or completing a design.

[2] The term 'short data sheet' is explained in section "Definitions".

[3] The product status of device(s) described in this document may have changed since this document was published and may differ in case of multiple devices. The latest product status information is available on the Internet at URL <http://www.ampleon.com>.

12.2 Definitions

Draft — The document is a draft version only. The content is still under internal review and subject to formal approval, which may result in modifications or additions. Ampleon does not give any representations or warranties as to the accuracy or completeness of information included herein and shall have no liability for the consequences of use of such information.

Short data sheet — A short data sheet is an extract from a full data sheet with the same product type number(s) and title. A short data sheet is intended for quick reference only and should not be relied upon to contain detailed and full information. For detailed and full information see the relevant full data sheet, which is available on request via the local Ampleon sales office. In case of any inconsistency or conflict with the short data sheet, the full data sheet shall prevail.

Product specification — The information and data provided in a Product data sheet shall define the specification of the product as agreed between Ampleon and its customer, unless Ampleon and customer have explicitly agreed otherwise in writing. An agreement according to which the functions and qualities of Ampleon products exceed those described in the Product data sheet is invalid.

12.3 Disclaimers

Maturity — After the relevant product(s) have passed the Release Gate in Ampleon's release process, Ampleon will confirm the final version in writing.

Limited warranty and liability — Ampleon uses its best efforts to keep the information in this document accurate and reliable. However, Ampleon gives no representations or warranties, expressed or implied, as to the accuracy or completeness of such information and assumes no liability for the consequences of the use of such information. Ampleon is not liable for content provided by an external information source.

In no event and irrespective of the legal basis (contract, tort (including negligence) statutory liability, misrepresentation, indemnity or any other area of law) shall Ampleon be liable for any indirect, incidental, punitive, special or consequential damages (including but without limitation loss of profit or revenue, loss of use or loss of production, loss of data, cost of capital, cost of substitute goods, property damage external to the Ampleon products and any damage, expenditure or loss arising out of such damage, business interruption, costs related to the removal or replacement of any products or rework charges) or any of the foregoing suffered by any third party.

Notwithstanding any damages that customer might incur for any reason whatsoever, Ampleon's aggregate and cumulative liability towards customer for the products described herein shall be limited in accordance with the *Terms and conditions of commercial sale* of Ampleon.

Right to make changes — Ampleon reserves the right to change information including but without limitation specifications and product descriptions published in this document at any time and without notice. This document supersedes and replaces all information regarding these products supplied prior to the publication hereof.

Suitability for use — Ampleon products are not designed, authorized or warranted to be suitable for use in life support, life-critical or safety-critical systems or equipment, nor in applications where failure or malfunction of an Ampleon product can reasonably be expected to result in personal injury, death or severe property or environmental damage. Insofar as a customer or another party nevertheless uses Ampleon products unlawfully for such purposes, Ampleon and its suppliers are not liable for any damages.

Applications — Applications that are described herein for any of these products are for illustrative purposes only. Ampleon makes no representation or warranty that such applications will be suitable for the specified use without further testing or modification.

Customers are responsible for the design and operation of their applications and products using Ampleon products, and Ampleon is not liable for any assistance with applications or customer product design. It is customer's sole responsibility to determine whether the Ampleon product is suitable and fit for the customer's applications and products planned, as well as for the planned application and use of customer's third party customer(s). Customers shall provide appropriate design and operating safeguards to minimize the risks associated with their applications and products.

Ampleon is not liable related to any default, damage, costs or problem which is based on any weakness or default in the customer's applications or products, or the application or use by customer's third party customer(s). Customer is responsible for and shall do all necessary testing for the customer's applications and products using Ampleon products in order to avoid a default of the applications and the products or of the application or use by customer's third party customer(s). Ampleon is not liable in this respect.

Limiting values — Stress above one or more limiting values (as defined in the Absolute Maximum Ratings System of IEC 60134) will cause permanent damage to the device. Limiting values are stress ratings only and (proper) operation of the device at these or any other conditions above those given in the Recommended operating conditions section (if present) or the Characteristics sections of this document is not guaranteed. Constant or repeated exposure to limiting values will permanently and irreversibly affect the quality and reliability of the device.

Terms and conditions of commercial sale — Ampleon products are sold subject to the general terms and conditions of commercial sale, as published at <http://www.ampleon.com/terms>, unless otherwise agreed in a valid written individual agreement. In the event of signing an individual agreement the terms and conditions of the respective agreement shall apply. Ampleon hereby expressly objects to and rejects the validity of customer's terms and conditions regarding the purchase of Ampleon products by customer.

No offer to sell or license — Nothing in this document may be interpreted or construed as an offer to sell products that is open for acceptance or the grant, conveyance or implication of any license under any copyrights, patents or other industrial or intellectual property rights.

Export control — This document as well as the item(s) described herein may be subject to export control regulations. Export might require a prior authorization from competent authorities.

Non-automotive qualified products — Unless this data sheet expressly states that this specific Ampleon product is automotive qualified, the product is not suitable for automotive use. It is neither qualified nor tested in accordance with automotive testing or application requirements. Ampleon is not liable for inclusion and/or use of non-automotive qualified products in automotive equipment or applications.

In the event that customer breaches this and uses the products for design and use in automotive applications in accordance with automotive specifications and standards, (a) Ampleon gives no warranty, representation

or other guarantees of any kind with respect to such automotive applications, use and specifications, and (b) such use is solely and exclusively at customer's own risk, and (c) customer fully indemnifies Ampleon against any and all liability, damages or failed product claims, including against third parties, arising out of customer's design and use of the product for automotive applications.

Translations — A non-English (translated) version of a document is for reference only. The English version shall prevail in case of any discrepancy between the translated and English versions.

12.4 Trademarks

Notice: All referenced brands, product names, service names and trademarks are the property of their respective owners.

13. Contact information

For more information, please visit: <http://www.ampleon.com>

For sales office addresses, please visit: <http://www.ampleon.com/sales>

14. Contents

1 **Product profile** 1

1.1 General description 1

1.2 Features and benefits 1

1.3 Applications 1

2 **Pinning information** 2

3 **Ordering information** 2

4 **Limiting values** 2

5 **Thermal characteristics** 3

6 **Characteristics** 3

7 **Test information** 4

7.1 Ruggedness in Doherty operation 4

7.1.1 At f = 791 MHz; tested on the Doherty application demo board 4

7.2 Impedance information 4

7.3 Test circuit 5

7.4 Graphical data 6

7.4.1 Pulsed CW 6

7.4.2 1-Carrier W-CDMA 7

7.4.3 2-Tone VBW 8

8 **Package outline** 9

9 **Handling information** 11

10 **Abbreviations** 11

11 **Revision history** 11

12 **Legal information** 12

12.1 Data sheet status 12

12.2 Definitions 12

12.3 Disclaimers 12

12.4 Trademarks 13

13 **Contact information** 13

14 **Contents** 14

Please be aware that important notices concerning this document and the product(s) described herein, have been included in section 'Legal information'.

© Ampleon Netherlands B.V. 2022. All rights reserved.

For more information, please visit: <http://www.ampleon.com>
 For sales office addresses, please visit: <http://www.ampleon.com/sales>

Date of release: 13 May 2022
 Document identifier: C4H10P600A