

## FH-VIW – 90° Horizontal Float Switch

Side-mounted float switches available in polypropylene, nylon, and Kynar, making them ideal for a variety of general use chemical applications. Easily mounted through a horizontal NPT fitting or internal through-hole, these liquid level sensors offer superior dependability and economy.

### FH-VIW

**FH-VIW-02** - PP 90 Degree Side Mounted Float Switch, M12 Bulkhead

**FH-VIW-SKY** - PP 90 Degree Side Mounted Float Switch, M12 Bulkhead



Part Number	Switch Type	Max Switching Current	Max Switching Voltage	Max Temp	Max Pressure	Specific Gravity
FH-VIW -02	50 Watt	0.5 Amps	200 VDC	80° C	25 psig	0.70
FH-VIW -SKY	5 Watt	0.25 Amps	175 VDC	80° C	25 psig	0.70

**Standard Features:** 22 AWG Wires, SKY modules offers a 24 AWG Cable Bundle option

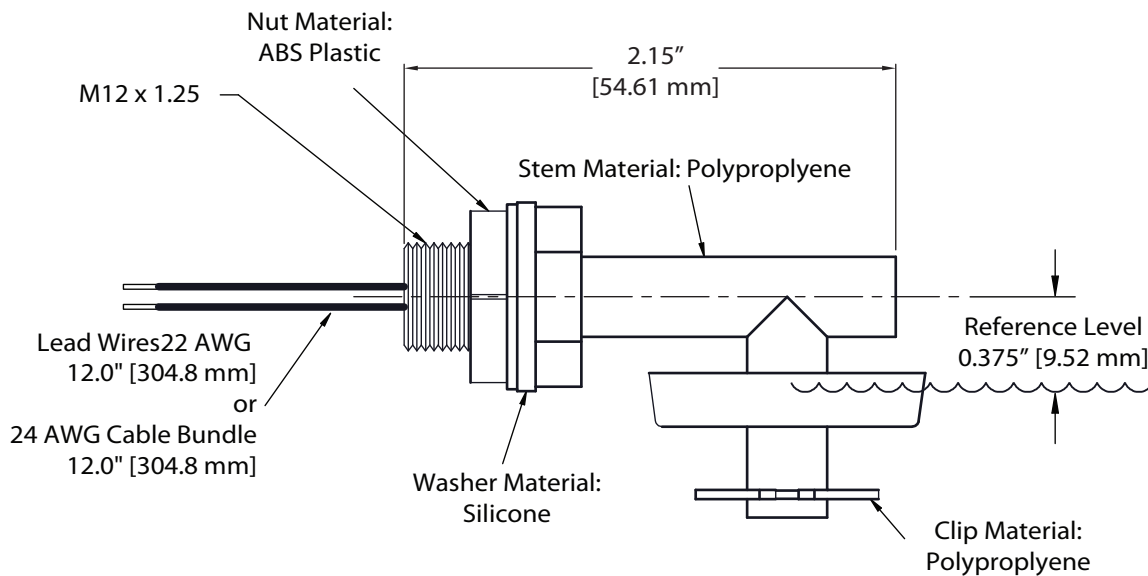

The 90-degree float switch design eliminates the problems often encountered with typical "pivot type" side-mounted float switches. The FH-VIW is available with 5 or 50-watt switching capabilities and optional Buna floats are available for oils and other low specific gravity float switch applications. Because horizontal sensors come as standard parts or customized OEM, it can be used in a vast amount of applications in many markets at a reasonable prices.