



TAOGLAS®



Datasheet

Accura GNSS L1/L5 Stacked Patch Multi-Band Antenna

Part No:
GVLB258.A

Description:

Single Feed Stacked Patch Antenna for GNSS L1 / L5, GLONASS, BeiDou B1/B2a

Features:

Single Feed Stacked Patch Assembly

Covering Bands

- GPS L1 & L5
- BeiDou B1/B2a
- Galileo E1 & E5a
- GLONASS G1
- IRNSS L5

Pin Mount

Dimensions: 25*25*8.12mm

RoHS & REACH Compliant

1. Introduction	3
2. Specifications	4
3. Antenna Characteristics	6
4. Radiation Patterns	9
5. Field Test Results	14
6. Mechanical Drawing	15
7. Antenna Integration Guide	16
8. Solder Recommendations	22
9. Packaging	23
<hr/>	
Changelog	24

Taoglas makes no warranties based on the accuracy or completeness of the contents of this document and reserves the right to make changes to specifications and product descriptions at any time without notice. Taoglas reserves all rights to this document and the information contained herein. Reproduction, use or disclosure to third parties without express permission is strictly prohibited.

Ireland & USA
ISO 9001:2015
Certified



Taiwan
ISO 9001:2015
Certified



046



IATF16949



1. Introduction



The Taoglas Accura GVLB258.A, is a multi-band GPS, BeiDou/Compass and IRNSS, high-performance directional antenna for high precision GPS and BeiDou accuracy and fast positioning. It utilizes a 25*25*8mm advanced wide-band dual stacked ceramic patch antenna with optimized gain for GPS L1/L5, Galileo, GLONASS and BeiDou bands.

Typical Applications Include:

- RTK
- Navigation
- Wearables
- Security
- Transportation
- Autonomous Vehicles
- Agriculture

The GVLB258.A has been tuned and tested on a 70 x 70 mm ground plane and exhibits excellent radiation patterns. The GVLB258.A has been optimised to cover the bands required for the next generation of L1/L5 GNSS receivers that are currently on the market.

Patch antennas can be specifically tuned to customer-specific device environments, subject to NRE and MOQ. Contact your regional Taoglas customer support team to request these services or additional support to integrate and test this antenna's performance in your device.

2. Specifications

GNSS Frequency Bands					
GPS	L1 1575.42 MHz	L2 1227.6 MHz	L5 1176.45 MHz		
	■	□	■		
GLONASS	G1 1602 MHz	G2 1248 MHz	G3 1207 MHz		
	■	□	□		
Galileo	E1 1575.24 MHz	E5a 1176.45 MHz	E5b 1201.5 MHz	E6 1278.75 MHz	
	■	■	□	□	
BeiDou	B1C 1575.42 MHz	B1I 1561 MHz	B2a 1176.45 MHz	B2b 1207.14 MHz	B3 1268.52 MHz
	■	■	■	□	□
L-Band	L-Band 1542 MHz				
	■				
QZSS (Regional)	L1 1575.42 MHz	L2C 1227.6 MHz	L5 1176.45 MHz	L6 1278.75e6	
	■	□	■	□	
IRNSS (Regional)	L5 1176.45 MHz				
	■				
SBAS	L1/E1/B1 1575.42 MHz	L5/B2a/E5a 1176.45 MHz	G1 1602 MHz	G2 1248 MHz	G3 1207 MHz
	■	■	■	□	□

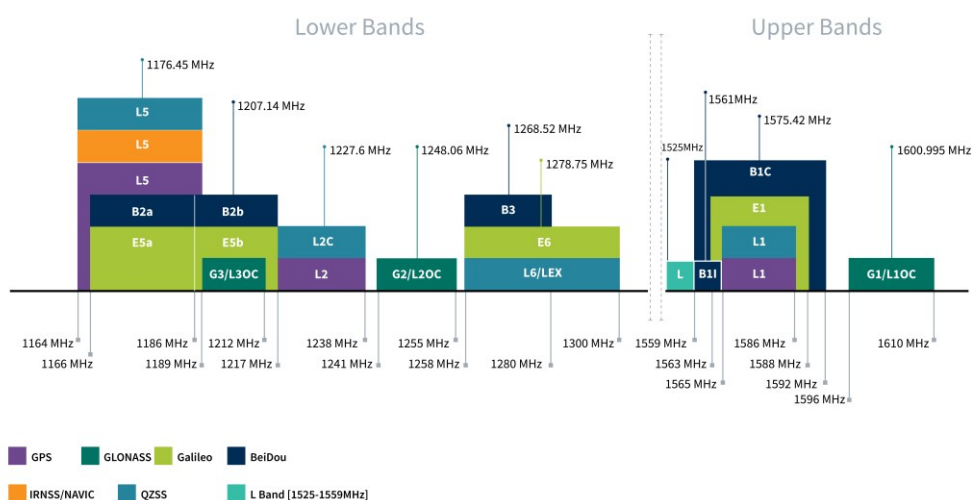

GNSS Bands and Constellations

Electrical				
Frequency (MHz)	GPS L5 / GLONASS E5a / IRNSS L5 / BeiDou B2a	BeiDou B1	GPS L1 / Galileo E1	GLONASS G1
	1166-1186	1559-1563	1563-1587	1593-1610
Efficiency (%)	58.5	68.5	60.7	62.5
Peak Gain(dBi)	2.31	2.94	2.87	3.08
Average Gain(dB)	-2.33	-1.64	-2.17	-2.04
Polarization	R.H.C.P.			
Radiation Pattern	Omni			
Impedance	50 Ω			

Mechanical	
Planner Dimension	25*25*8mm
Ground Plane	70*70mm
Connection Type	Pin & Adhesive Mount
Weight	18g

Environmental	
Temperature Range	-40°C to 85°C
Humidity	Non-condensing 65°C 95% RH

3. Antenna Characteristics

3.1 Return Loss

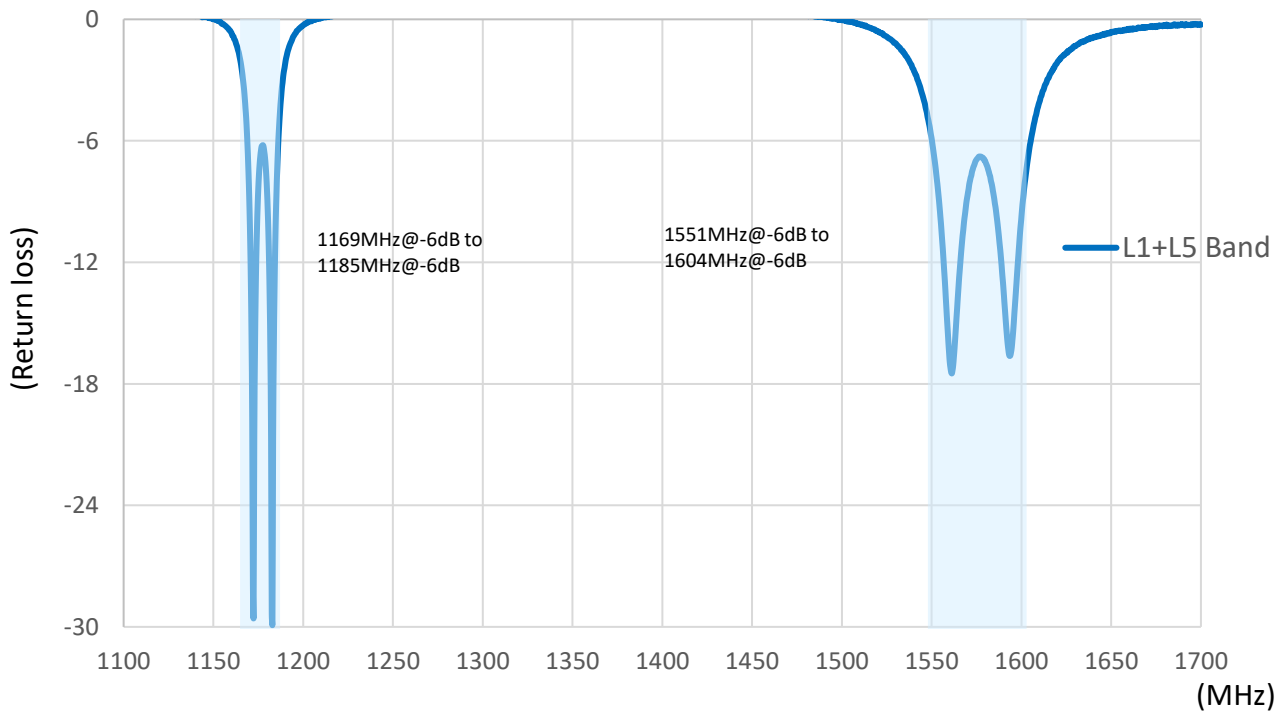

3.2 Efficiency

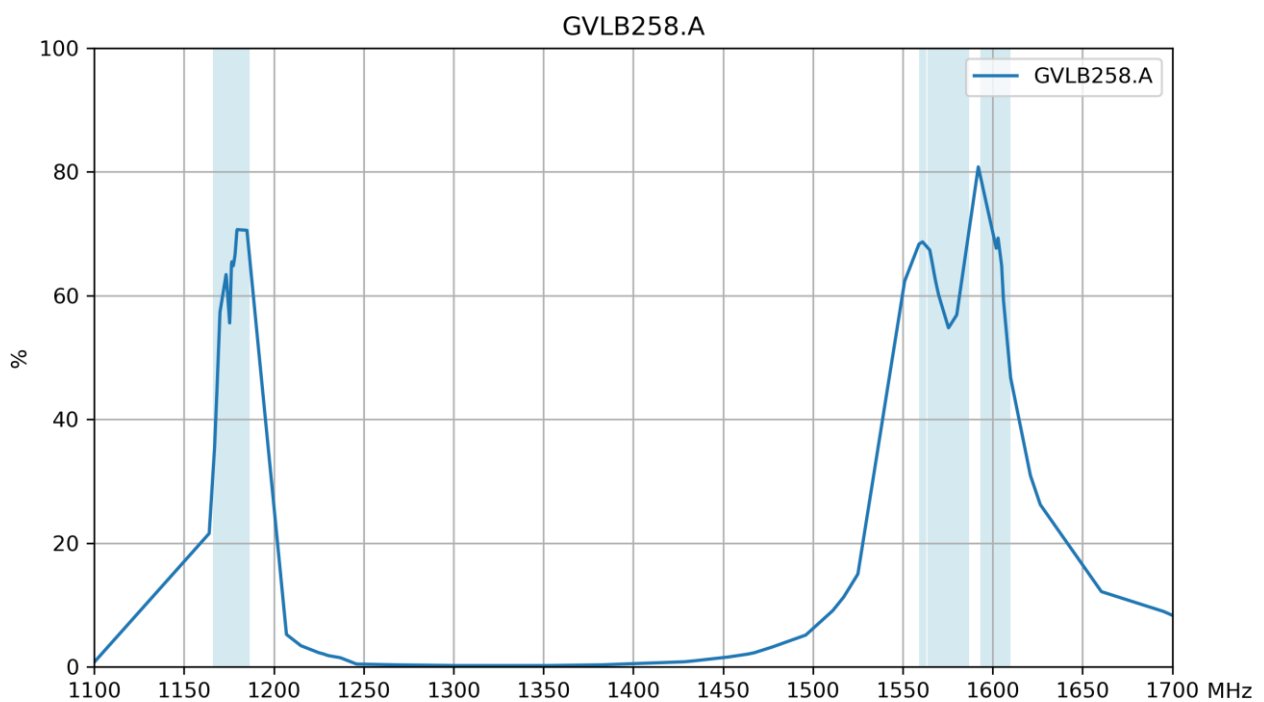

3.3 Average Gain

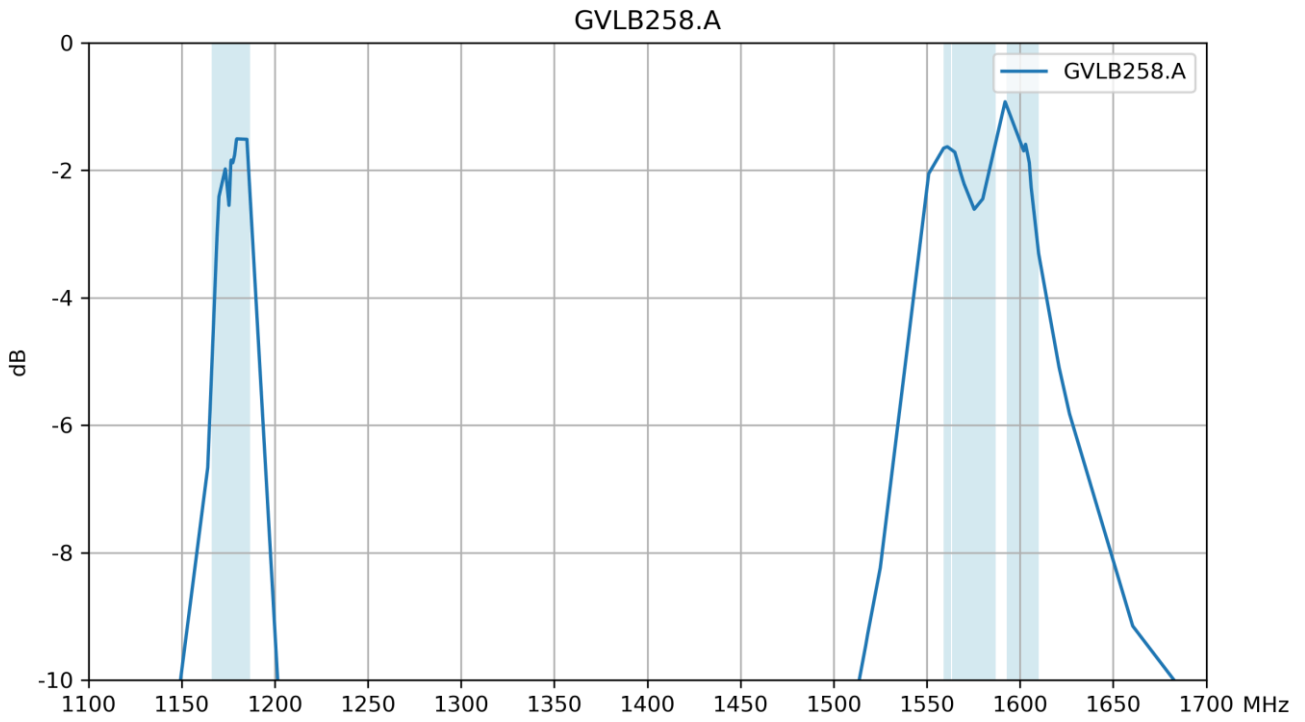

3.4 Peak Gain

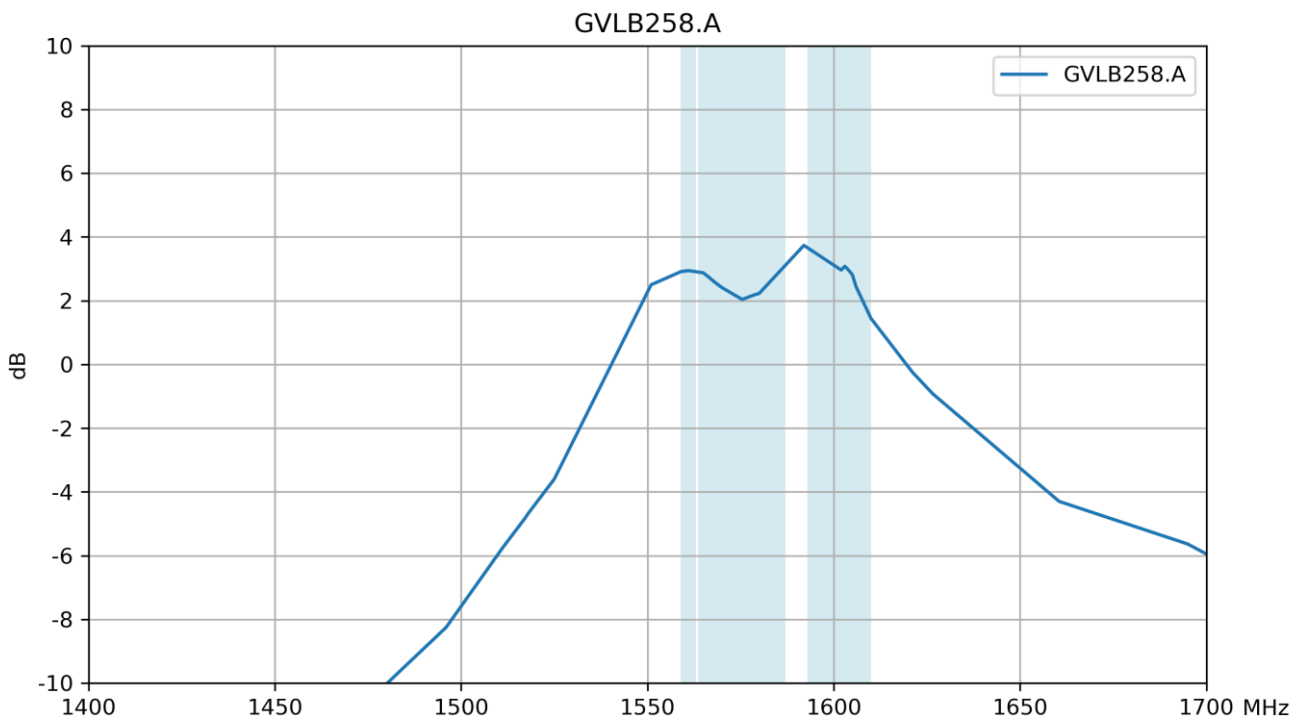

3.5 Axial Ratio – X-Z

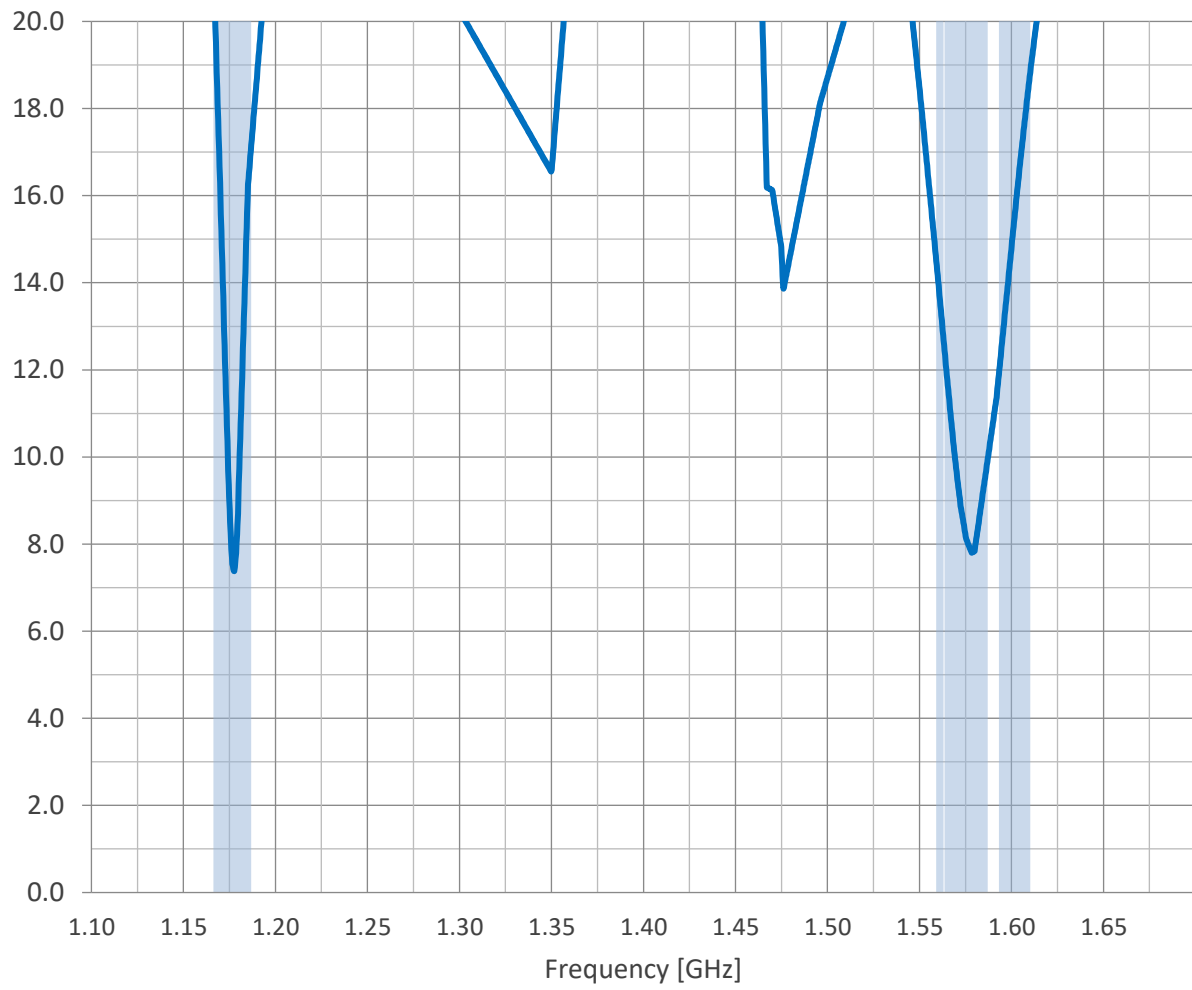

4. Radiation Patterns

4.1 Test Setup

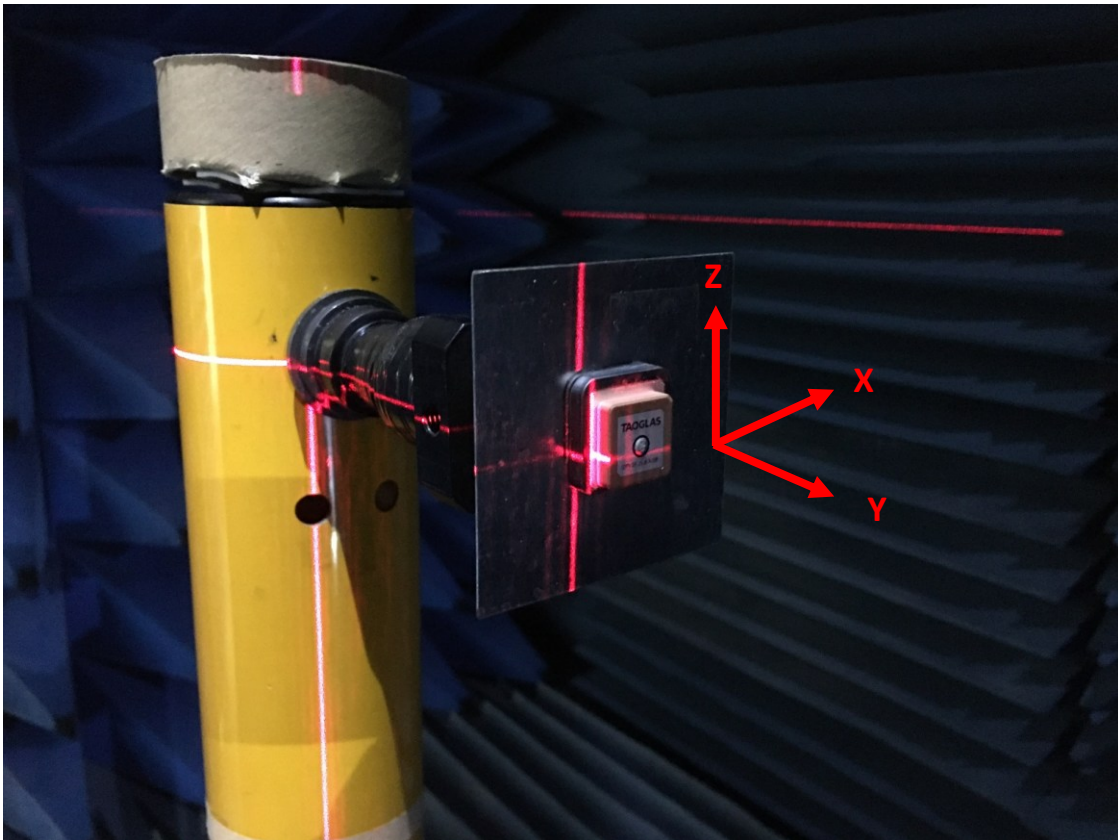

Tested on 70*70mm Ground Plane Evaluation Board

4.2 Radiation Patterns

1176MHz

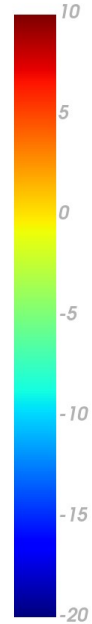
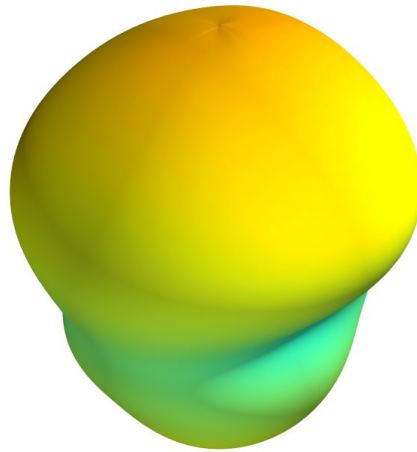

XY Plane

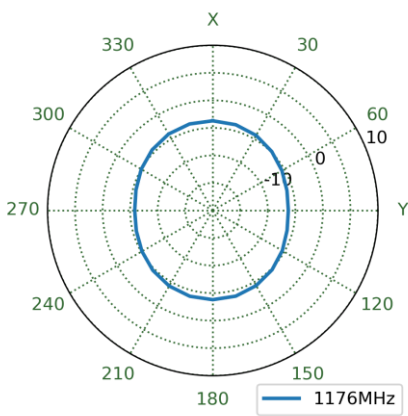

XZ Plane

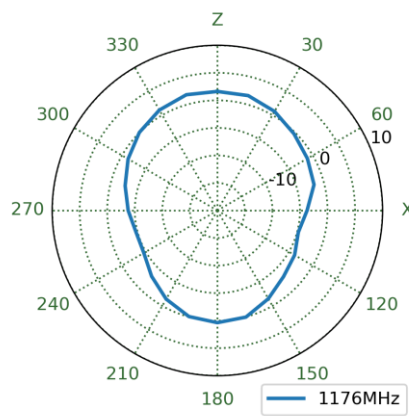

YZ Plane

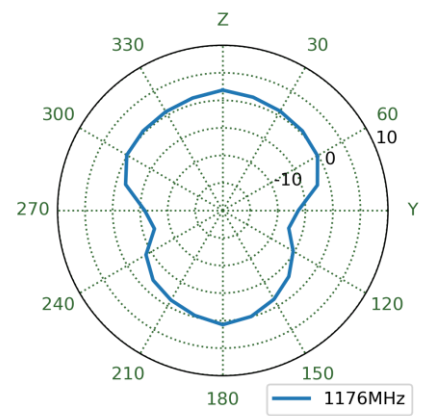

1561MHz

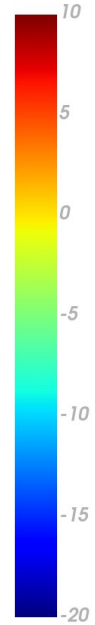
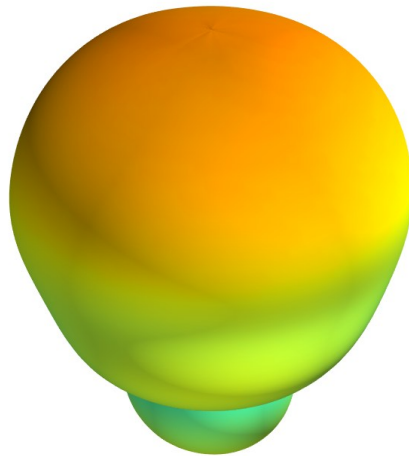

XY Plane

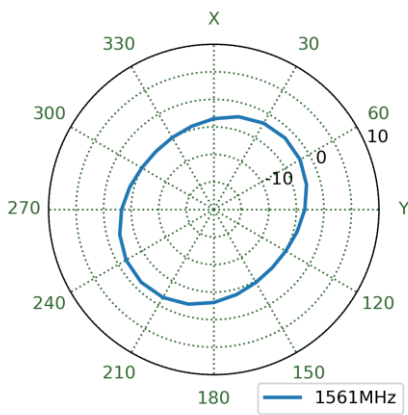

XZ Plane

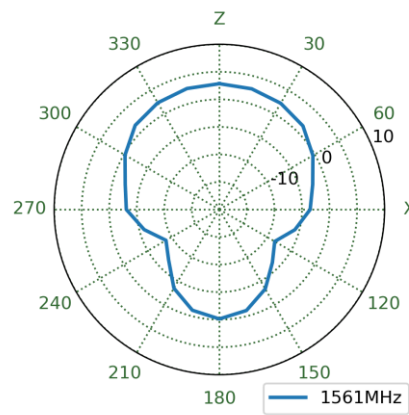

YZ Plane

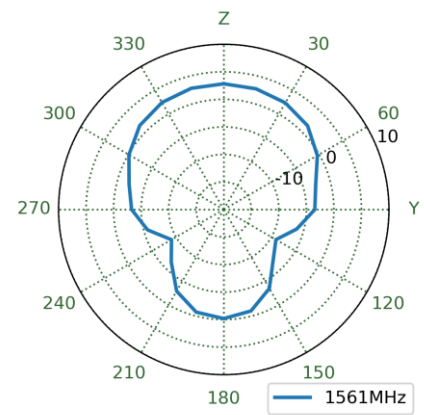

1575MHz

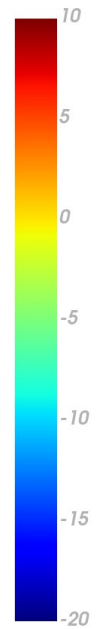
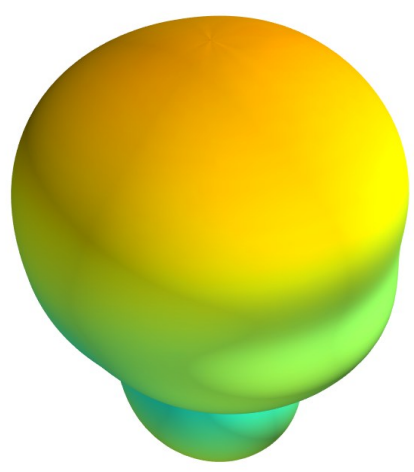

XY Plane

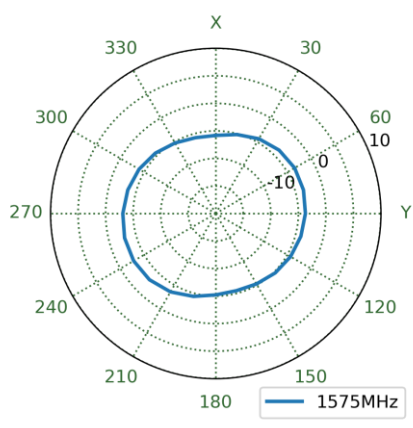

XZ Plane

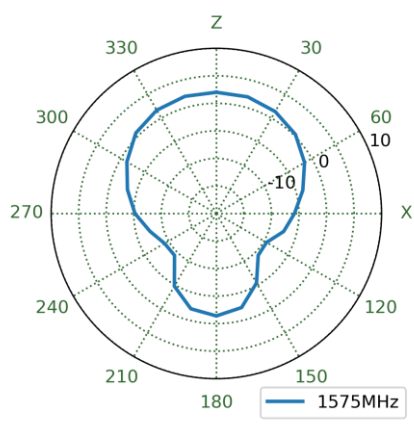

YZ Plane

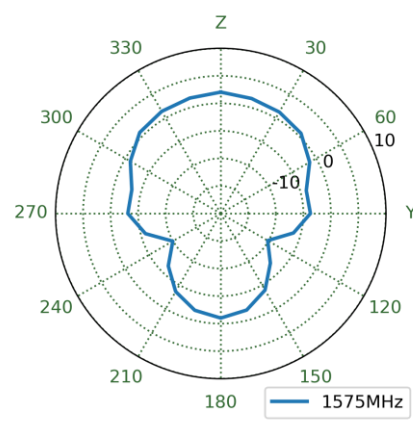

1602MHz

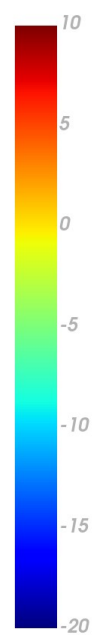
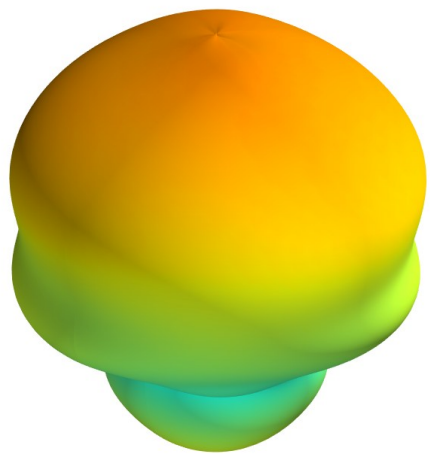

XY Plane

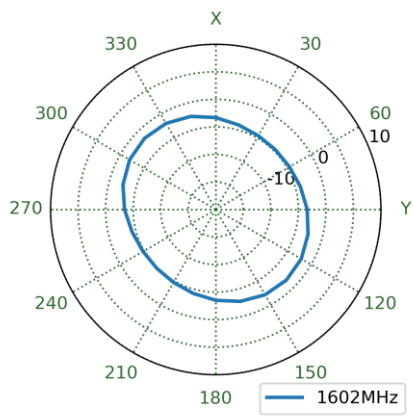

XZ Plane

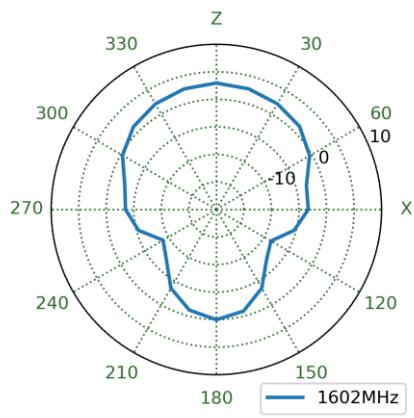

YZ Plane

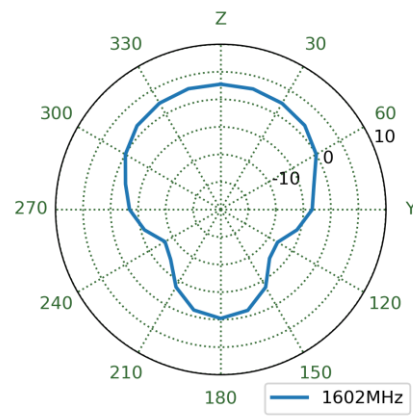

5. Field Test Results

This section outlines the field test result for GVLB258.A antenna. The test was performed when the antenna was mounted on a static rooftop test set up in an open sky environment for a minimum of **6 hours**.

Taoglas will show the field test results using the following receivers:

5.1 Ublox NEO-F9P-15B

Receiver features:

- Multi-band GNSS: GPS / QZSS (L1C/A, L5) GLONASS (L1OF) Galileo (E1-B/C, E5a) BeiDou (B1I, B2a) NavIC (SPS-L5)
- Multi-band PPP-RTK with fast convergence times and reliable performance
- Nav. update rate RTK up to 25 Hz
- Position accuracy = RTK 0.01 m + 1 ppm CEP

Positioning Accuracy Table (2D Accuracy)					
Test Condition	DRMS(cm)	CEP (50%)	DRMS (68%)	2DRMS (95-98.2%)	TTFF (sec)
70x70mm Ground Plane	PPP-RTK DISABLED	44.91	53.99	107.98	25
	PPP-RTK ENABLED	9.04	11.71	23.42	26

*The RTK correction service used in previous measurements provides superior corrections compared to the PPP-RTK service used for measurements on the NEO-F9P.

PPP-RTK Availability
70x70 mm ground plane

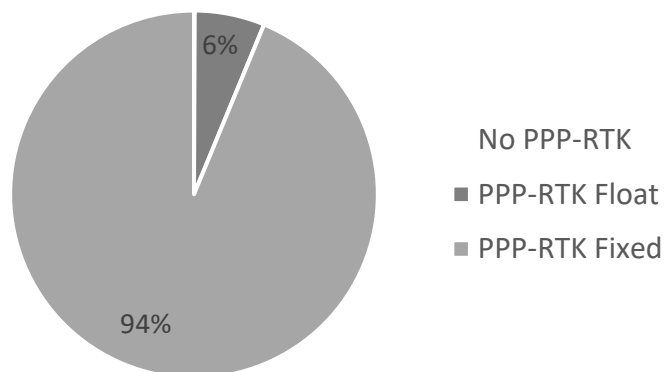

6. Mechanical Drawing (Units: mm)

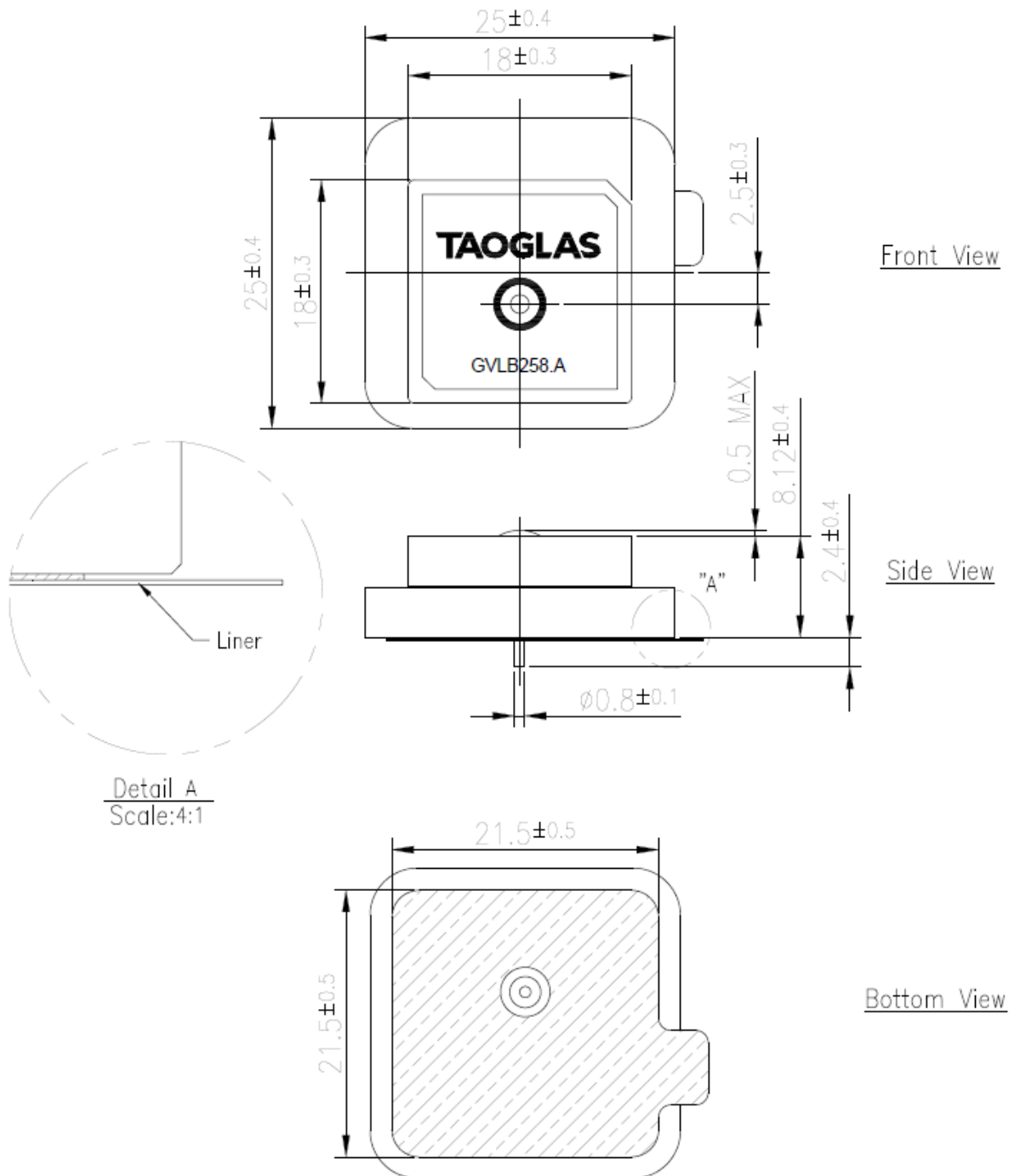

7. Antenna Integration Guide

The following is an example on how to integrate the GVLB258.A into a design. The GVLB258.A has one pin which is used for the RF Feed. Taoglas recommends using a minimum of 70x70mm ground plane to ensure optimal performance.



Top view of an example 70x70mm PCB Reference Design.

7.1 Schematic Symbol and Pin Definition

The circuit symbol for the antenna is shown below. The antenna has 1 pin as indicated below.

Pin	Description
1	RF Feed

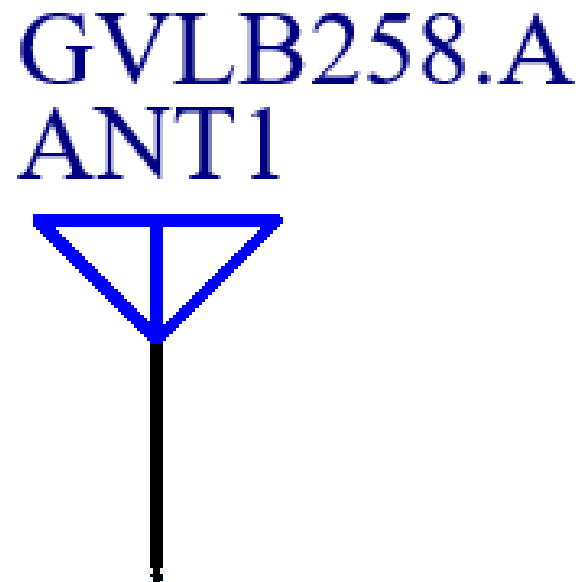

Please note you can download the 3D model and 2D drawing files from the website here: [GVLB258.A](https://www.taoglas.com/GVLB258.A)

7.2 Antenna Footprint



PIN	DESCRIPTION
1	RF FEED

7.3 Copper Clearance

The footprint and clearance on the PCB must comply with the antenna's specification. The PCB layout shown in the diagrams below demonstrates the GVLB258.A clearance area for Pin 1 (RF Feed Pad). The bottom copper keep out area only applies to the bottom layer and the top copper keep out area applies to all other layers. There should be a $\varnothing 3\text{mm}$ copper clearance around the antenna pins on the top side of the PCB with a $\varnothing 3.5\text{mm}$ copper clearance around the antenna pins on the bottom side.

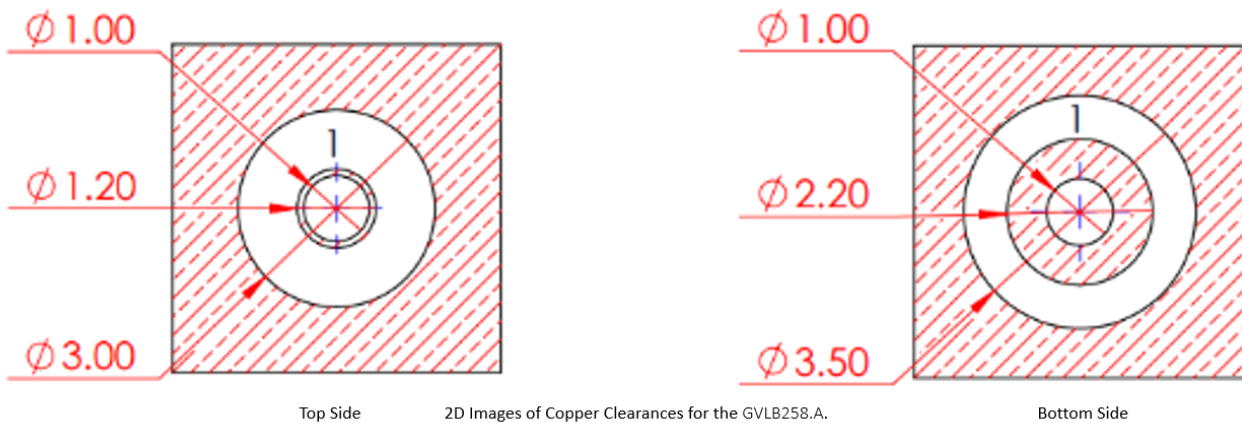

7.4 Antenna Integration

The GVLB258.A should be placed in the centre of the PCB to take advantage of the ground plane. The RF traces must maintain a 50 Ohm transmission line. Ground vias should be placed around the copper clearance area and the transmission line.



Bottom view of the PCB Reference Design, showing transmission lines and integration notes.

7.5 Final Integration

The bottom side image shown below highlights the antenna transmission line. Taoglas recommends using a minimum of 70x70mm ground plane to ensure optimal performance

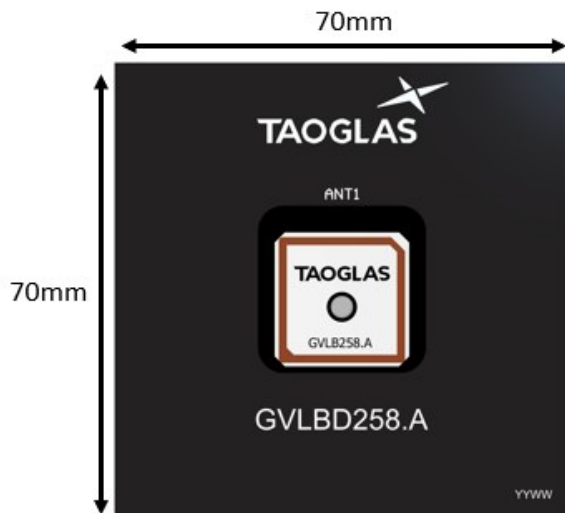

Top Side (70x70mm example PCB Reference Design)

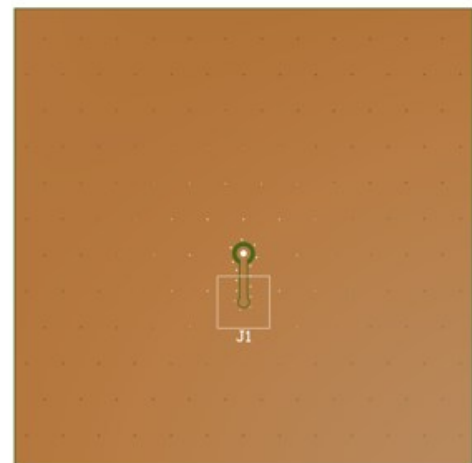
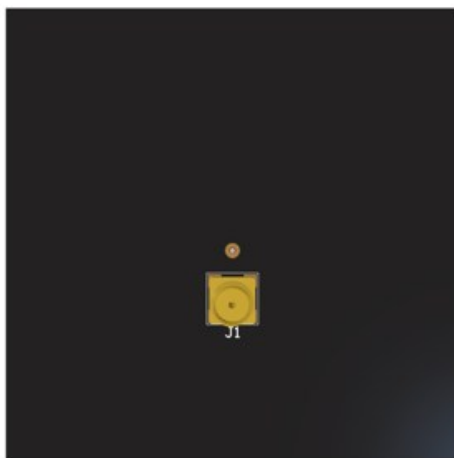

Bottom Side

8. Solder Recommendations

8.1 Manual Soldering Method

Soldering Temperature: 360-380°C

Soldering Duration: 3~4 seconds



8.2 Automated Soldering Machine

Soldering Temperature: 360-380°C

Soldering Duration: 3~4 seconds

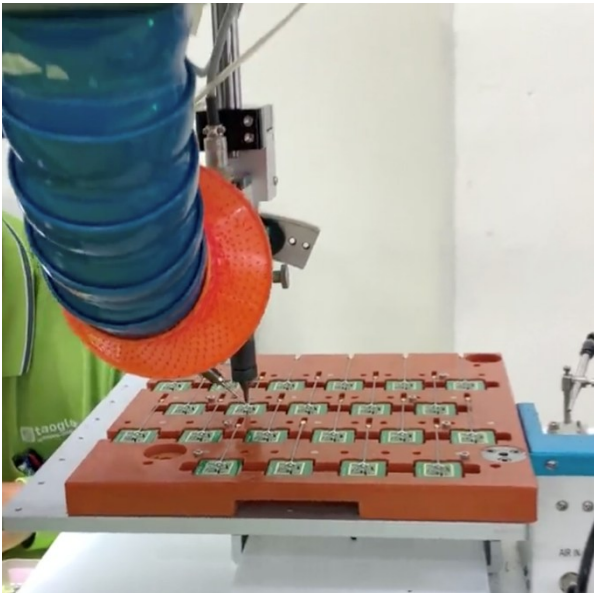

Please note that this process will require a one-time fixture to be made for each PCB design.

9. Packaging

24pcs GVLB258.A per Tray
 Tray Dimensions: 255*144*8mm
 Weight: 0.460Kg

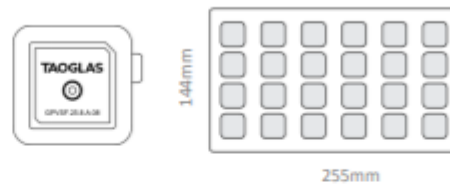

96pcs GVLB258.A per Inner Carton
 Dimensions: 263*154*96mm
 Weight: 2Kg

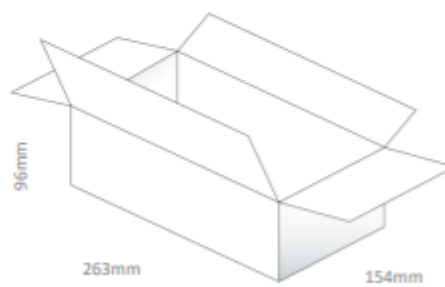

384pcs GVLB258.A per Large Carton
 Dimensions: 327*280*218mm
 Weight: 9Kg

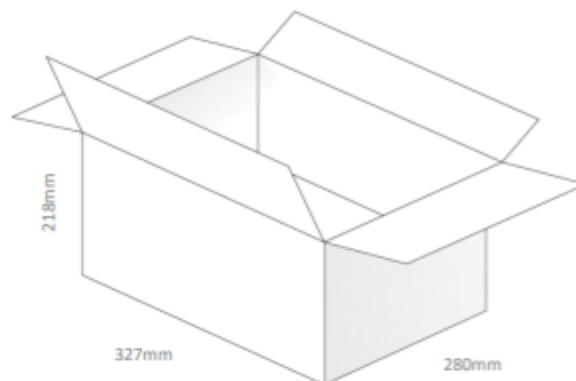

Pallet Dimensions:
 1200*1000*1280mm
 36 Cartons Per Pallet
 9 Cartons Per Layer, 4 Layers

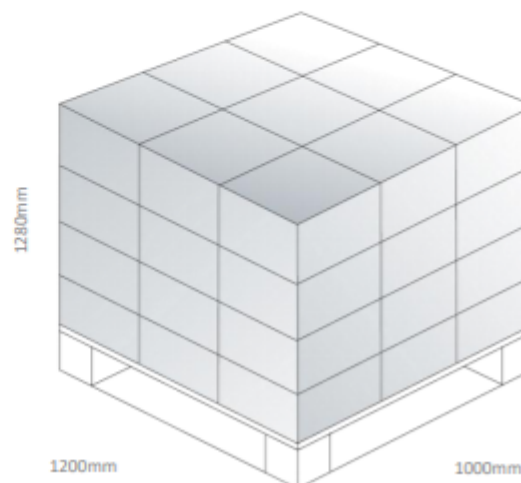

Changelog for the datasheet

SPE-21-8-082 – GVLB258.A

Revision: F (Current Version)

Date:	2024-10-30
Notes:	Updated Antenna Integration Guide
Author:	Cesar Sousa

Previous Revisions

Revision: E

Date:	2023-11-07
Notes:	Added Antenna Integration Guide and solder reflow profile
Author:	Cesar Sousa

Revision: D

Date:	2023-07-25
Notes:	Updated Antenna Field Testing
Author:	Gary West

Revision: C

Date:	2022-02-21
Notes:	Updated GNSS Bands & Constellations Graphics
Author:	Cesar Sousa

Revision: B

Date:	2022-08-25
Notes:	Updated Footprint Information and ME Drawing.
Author:	Gary West

Revision: A (Original First Release)

Date:	2021-09-06
Notes:	Initial Release
Author:	Jack Conroy



TAOGLAS®

www.taoglas.com

