

Click to
ORDER
samples

AMES75-NZ



Enclosed

The new AMES75-NZ is a brand-new AC/DC converter that offers much greater cost effectiveness due to material normalization and production automation also leading to improved reliability and performance. Offering a commercial input voltage range of 90-264VAC and an output voltage range from 5-48V, this series will offer many benefits to your new system design.

This new series offers great operating temperatures, from -30°C to 70°C also features an isolation of 4000VAC for improved reliability and system safety. Furthermore, a higher MTBF of 600,000h, output short circuit protection (OSCP), output over-current protection (OCP) and an output over-voltage protection (OVP) come standard with the series.

The AMES75-NZ is perfect for street lighting controls, grid power, LED, instrumentation, industrial controls, communication and civil applications.

Features

- Universal Input: 90 - 264VAC/127 - 370VDC
- Operating Temp: -30 °C to +70 °C
- High isolation voltage: Up to 4000VAC
- Output short circuit, over-current, over-voltage protection
- Regulated Output

Summary

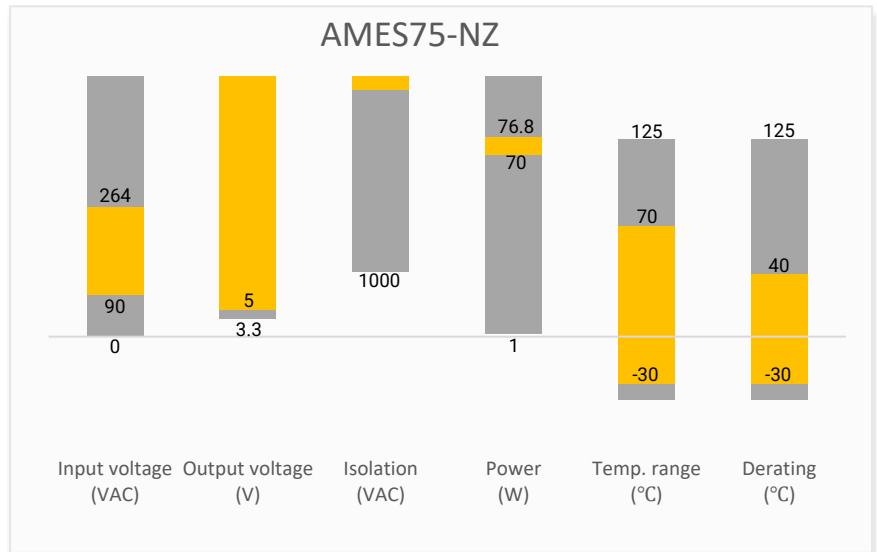

Training



Product Training Video
(click to open)



Press Release

Coming Soon!

Application Notes

Applications



Power Grid



Industrial



Telecom



Instrumentation

Models & Specifications

Single Output

Model	Input Voltage (VAC/Hz)	Input Voltage (VDC)	Max Output Wattage (W)	Output Voltage (V)	Output Voltage Adjustable Range (V)	Output Current max (A)	Maximum capacitive load (μ F)	AVG.Efficiency @115/230VAC Typ. (%)
AMES75-5SNZ-P	90-264/47-63	127-370	70	5	4.5-5.5	14	10000	87
AMES75-12SNZ-P	90-264/47-63	127-370	72	12	10.2-13.8	6	6000	88
AMES75-15SNZ-P	90-264/47-63	127-370	75	15	13.5-18	5	5000	88
AMES75-24SNZ-P	90-264/47-63	127-370	76.8	24	21.6-28.8	3.2	1500	88.5
AMES75-36SNZ-P	90-264/47-63	127-370	75.6	36	32.4-39.6	2.1	1000	89
AMES75-48SNZ-P	90-264/47-63	127-370	76.8	48	43.2-52.8	1.6	680	90

Note: The "-P" suffix indicates a terminal protective cover (ex. AMES75-5SNZ-P). For optional conformal coating, add "Q" after the "-P" (ex. AMES75-5SNZ-PQ is conformal coated version with terminal protective cover).

Parameters	Conditions	Typical	Maximum	Units
Input current	115VAC		1.7	A
	230VAC		0.85	A
Inrush current	cold start, 115VAC	35		A
	cold start, 230VAC	50		A
Leakage current	240VAC		0.75	mA

Output Specifications

Parameters	Conditions	Typical	Maximum	Units
Voltage accuracy	Full load, 5V output	± 2		%
	Full load, Others	± 1		%
Line regulation	Full load	± 0.5		%
Load regulation	0-100% load, 5V output	± 1		%
	0-100% load, Others	± 0.5		%
Ripple & Noise*	5V output	100		mV p-p
	12V, 15V output	120		mV p-p
	24V output	150		mV p-p
	36V, 48V output	200		mV p-p
Hold up time	115VAC	20		ms
	230VAC	60		ms
Rise time	115VAC	20		ms
	230VAC	30		ms
Start-up time	115VAC	800		ms
	230VAC	500		ms

* Ripple and Noise are measured at 20MHz bandwidth with a 47 μ F electrolytic capacitor and a 0.1 μ F ceramic capacitor. Please refer to the application note for specific details.

Isolation Specifications				
Parameters	Conditions	Typical	Rated	Units
Tested I/O voltage	60 sec		4000	VAC
Tested Input to GND voltage	60 sec		2000	VAC
Tested Output to GND voltage	60 sec		1250	VAC
Resistance (I/O, I/O to GND)	500VDC		100	MΩ

General Specifications				
Parameters	Conditions	Typical	Maximum	Units
Switching Frequency		65		KHz
Over Current protection	Auto recovery	≥ 110	150	% of Iout
Over voltage protection	5V output, shut down, Manual recovery		6.75	VDC
	12V output, shut down, Manual recovery		16.2	VDC
	15V output, shut down, Manual recovery		21.75	VDC
	24V output, shut down, Manual recovery		33.6	VDC
	36V output, shut down, Manual recovery		48.6	VDC
	48V output, shut down, Manual recovery		64.8	VDC
Short circuit protection	Hiccup, Continuous, Auto recovery			
Operating temperature	See derating graph	-30	70	°C
Storage temperature		-40	85	°C
Power consumption			0.3	W
Power derating	40 °C to 70 °C, 5V output	1.33		% / °C
	50 °C to 70 °C, Others	2		% / °C
	90VAC ~ 100VAC	2		% / VAC
Ambient temperature derating	Operating altitude > 2000m	5		°C / 1000m
Temperature coefficient		±0.03		% / °C
Cooling	Free air convection			
Humidity	Non-condensing	≥ 10	95	% RH
	Non-condensing, Operating	≥ 20	90	% RH
Vibration	10~ 500Hz, 5G 10min./1cycle, 60min. each along X, Y,Z axes			
Case material	Metal			
Weight		250		g
Dimensions (L x W x H)		3.90 x 3.82 x 1.18inch (99.0 x 97.0 x 30.0mm)		
MTBF	> 600 000 hrs (MIL-HDBK -217F, t=+25°C)			
NOTE: All specifications in this datasheet are measured at an ambient temperature of 25°C, humidity<75%, nominal input voltage and at rated output load unless otherwise specified.				

Safety Specifications

Parameters

Standards	Over voltage category	Design to meet III; According to BS EN/EN61558, BS EN/EN50178, BS EN/EN60664-1, BS EN/EN62477-1
	Information technology Equipment	Design to meet BS EN/EN62368-1, BS EN/EN60335-1, BS EN/EN61558-1
	EMC - Conducted and radiated emission	BS EN/EN55032 (CISPR32) Class B
	Harmonic current	IEC 61000-3-2, Class A
	Voltage Changes, Voltage Fluctuation and Flicker	IEC 61000-3-3, Class A
	Electrostatic Discharge Immunity	IEC 61000-4-2, Criteria A
	RF, Electromagnetic Field Immunity	IEC 61000-4-3, Criteria A
	Electrical Fast Transient/Burst Immunity	IEC 61000-4-4, Criteria A
	Surge Immunity	IEC 61000-4-5, Criteria A
	RF, Conducted Disturbance Immunity	IEC 61000-4-6, Criteria A
Power-frequency Magnetic Field	IEC 61000-4-8, Criteria A	
Voltage dips, Short Interruptions Immunity	IEC 61000-4-11, Criteria A	

Derating

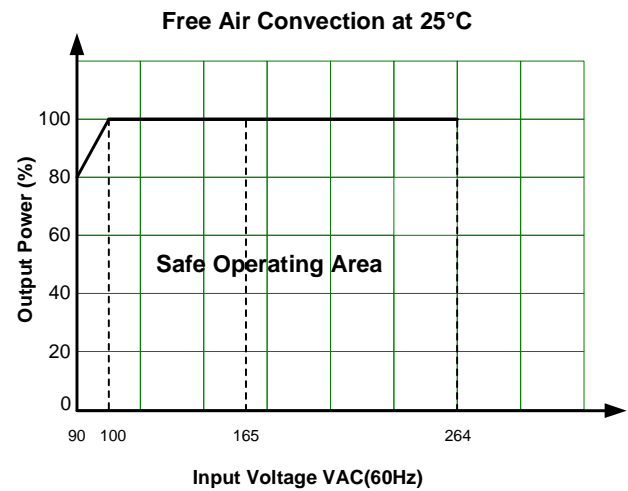
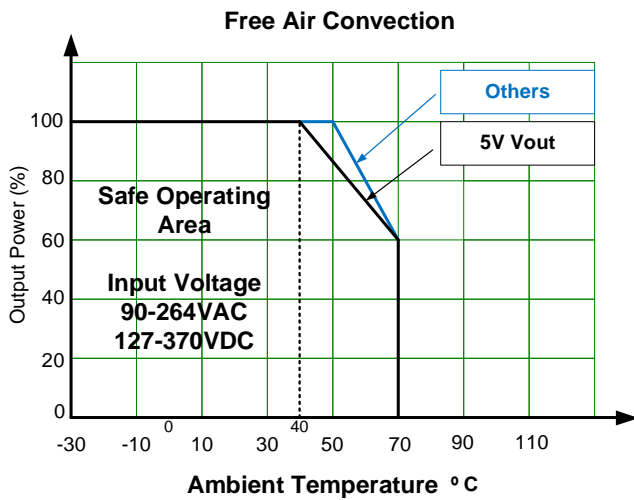

Dimensions

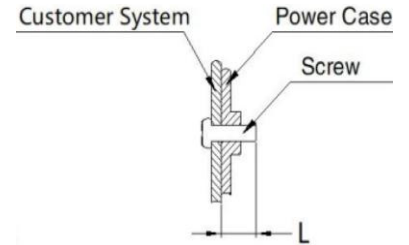
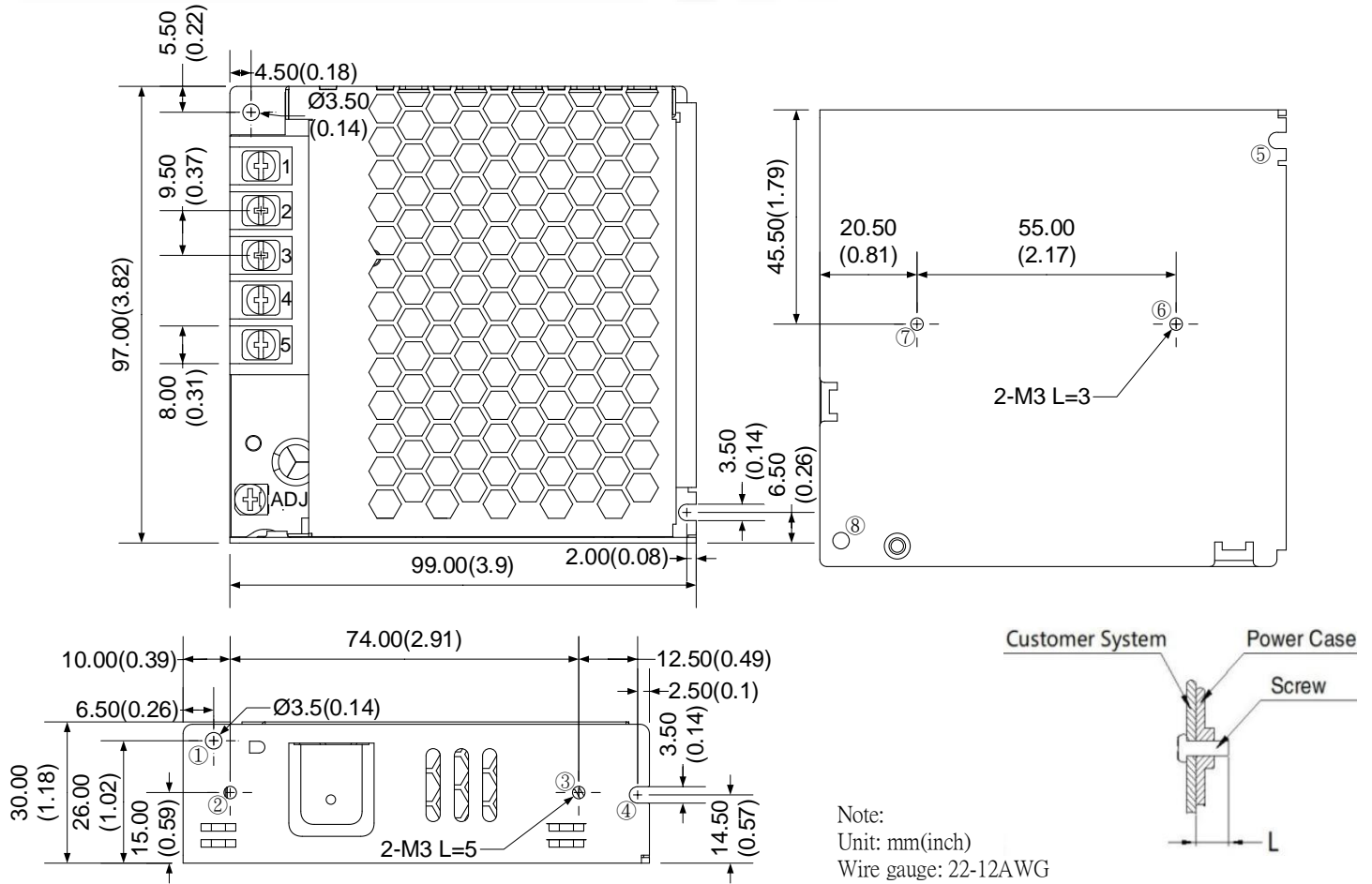

Note:
Unit: mm(inch)
Wire gauge: 22-12AWG
Connector tightening torque: M3.5, 0.8N-m
General tolerance: $\pm 1.0(0.04)$
At least one of the ① - ⑧ location must be connected to PE

Single Pin Output Specifications	
Pin	Function
1	Input (L)
2	Input (N)
3	PE GND
4	-V Output
5	+V Output
ADJ	Vout voltage adj knob

NOTE: 1. Datasheets are updated as needed and as such, specifications are subject to change without notice. Once printed or downloaded, datasheets are no longer controlled by Aimtec; refer to www.aimtec.com for the most current product specifications. 2. Product labels shown, including safety agency certifications on labels, may vary based on the date manufactured. 3. Mechanical drawings and specifications are for reference only. 4. All specifications are measured at an ambient temperature of 25°C, humidity < 75%, nominal input voltage and at rated output load unless otherwise specified. 5. Aimtec may not have conducted destructive testing or chemical analysis on all internal components and chemicals at the time of publishing this document. CAS numbers and other limited information are considered proprietary and may not be available for release. 6. This product is not designed for use in critical life support systems, equipment used in hazardous environments, nuclear control systems or other such applications which necessitate specific safety and regulatory standards other than the ones listed in this datasheet. 7. Warranty is in accordance with Aimtec's standard Terms of Sale available at www.aimtec.com.