

SERIES: VHB200W | **DESCRIPTION:** DC-DC CONVERTER

FEATURES

- up to 200 W isolated output
- industry standard half brick package
- 4:1 input range (10~36 V, 18~75 V)
- single output from 3.3~48 V
- 1,500 V isolation
- over current, over temperature, over voltage, and short circuit protections
- remote on/off
- efficiency up to 89%



MODEL	input voltage range (Vdc)	output voltage (Vdc)	output current max (A)	output power max (W)	ripple and noise ¹ max (mVp-p)	efficiency
						typ (%)
VHB200W-Q24-S3R3	10 ~ 36	3.3	50	165	100	87
VHB200W-Q24-S5	10 ~ 36	5	40	200	100	87
VHB200W-Q24-S12	10 ~ 36	12	16.7	200	150	86
VHB200W-Q24-S15	10 ~ 36	15	13.3	200	150	86
VHB200W-Q24-S24	10 ~ 36	24	8.3	200	240	87
VHB200W-Q24-S28	10 ~ 36	28	7.1	200	280	87
VHB200W-Q24-S48	10 ~ 36	48	4.2	200	240	86
VHB200W-Q48-S3R3	18 ~ 75	3.3	40	132	100	88
VHB200W-Q48-S5	18 ~ 75	5	40	200	100	89
VHB200W-Q48-S12	18 ~ 75	12	16.7	200	150	88
VHB200W-Q48-S15	18 ~ 75	15	13.3	200	150	88
VHB200W-Q48-S24	18 ~ 75	24	8.3	200	240	88
VHB200W-Q48-S28	18 ~ 75	28	7.1	200	280	88
VHB200W-Q48-S48	18 ~ 75	48	4.2	200	240	87

Notes: 1. ripple and noise are measured at 20 MHz BW with 10µF tantalum capacitor and 1µF ceramic capacitor across output

PART NUMBER KEY

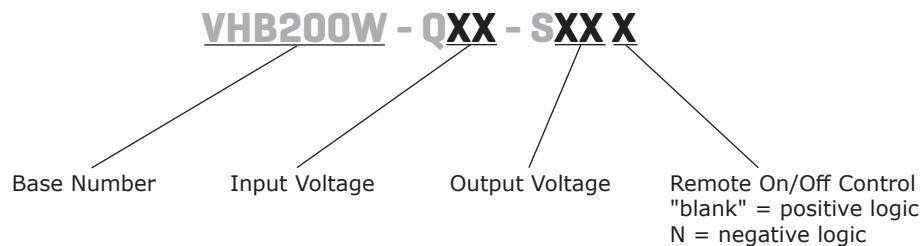

INPUT

parameter	conditions/description	min	typ	max	units
operating input voltage		10	24	36	Vdc
		18	48	75	Vdc
under voltage lockout	power up	24 V input	9.5		Vdc
		48 V input	17		Vdc
	power down	24 V input	8.5		Vdc
		48 V input	16		Vdc
positive logic remote on/off ¹					
filter	PI type				

Notes: 1. logic compatibility, open collector ref to -input
Module ON, >3.5 Vdc or open circuit
Module OFF, <1.8 Vdc

OUTPUT

parameter	conditions/description	min	typ	max	units
line regulation	measured from high line to low line			±0.2	%
load regulation	measured from full load to zero load			±0.2	%
voltage accuracy				±1.5	%
transient response	25% step load change			500	µs
adjustability ²			±10		%
switching frequency	100% load, input voltage range		250		kHz
temperature coefficient			±0.03		%/°C

Notes: 2. trim-up: connect a resistor between the trim pin and +Sense
trim-down: connect a resistor between the trim pin and -Sense

PROTECTIONS

parameter	conditions/description	min	typ	max	units
over voltage protection	%Vo	115		140	%
short circuit protection	continuous				
current limit	% nominal output current	110		150	%
thermal shutdown case temp.			110		°C

SAFETY AND COMPLIANCE

parameter	conditions/description	min	typ	max	units
isolation voltage	input to output	1,500			Vdc
	input to case	1,500			Vdc
	output to case	1,500			Vdc
isolation resistance		10			MΩ
isolation capacitance			1,000		pF
safety approvals	UL60950-1				
RoHS compliant	yes				

ENVIRONMENTAL

parameter	conditions/description	min	typ	max	units
case operating temperature	see derating curve	-40		100	°C
storage temperature		-55		105	°C
humidity	non-condensing			95	%

DERATING CURVE

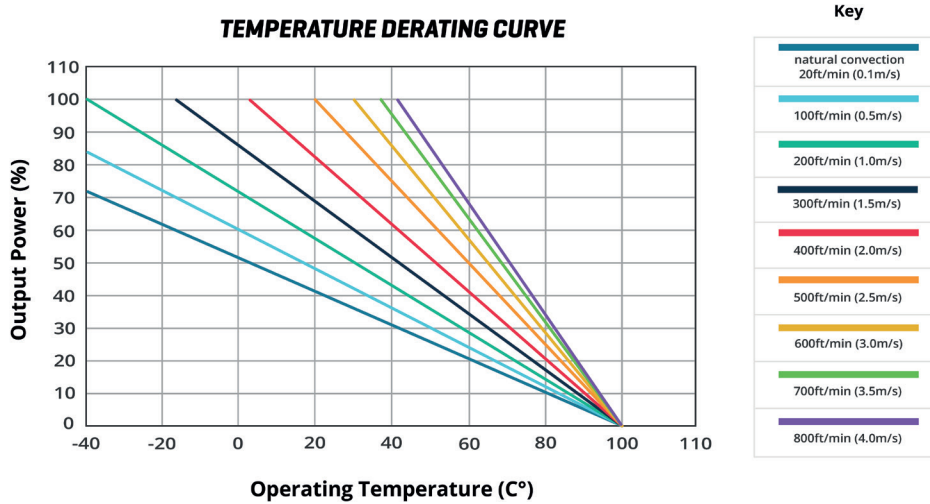

MECHANICAL

parameter	conditions/description	min	typ	max	units
dimensions	57.9 x 61.0 x 13.2 (2.28 x 2.40 x 0.52 inch)				mm
case material	aluminum baseplate with plastic case				
weight			114		g

MECHANICAL DRAWING

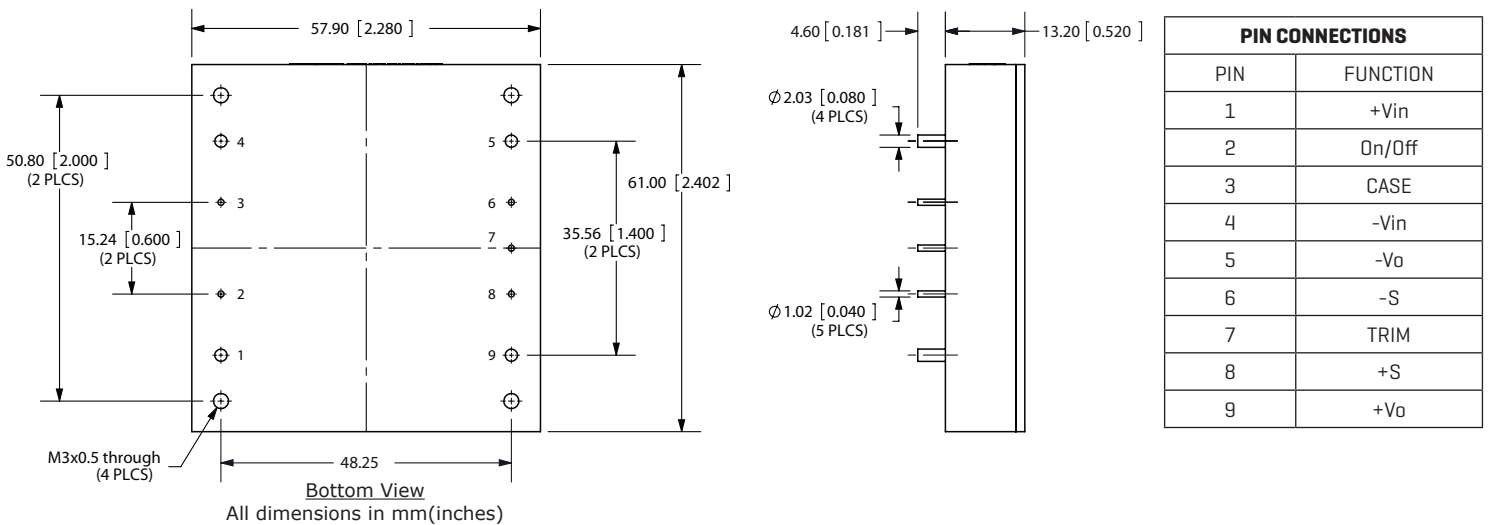

Note: All specifications measured at 25°C, nominal input voltage, and full load unless otherwise noted.

REVISION HISTORY

rev.	description	date
1.0	initial release	08/08/2008
1.01	new template applied	08/05/2011
1.02	add remote on/off control to the part number key	11/23/2011
1.03	features updated	12/20/2011
1.04	misc. updates and corrections	02/14/2012
1.05	V-Infinity branding removed	09/07/2012
1.06	updated spec	04/01/2013
1.07	company logo updated	02/09/2021
1.08	derating curve inserted	03/04/2021
1.09	company address updated	11/14/2024

The revision history provided is for informational purposes only and is believed to be accurate.



CUI INC
a bel group

Headquarters

15575 SW Sequoia Pkwy #100
Portland, OR 97224
800.275.4899

Fax 503.612.2383
cui.com
techsupport@cui.com

CUI offers a two (2) year limited warranty. Complete warranty information is listed on our website.

CUI reserves the right to make changes to the product at any time without notice. Information provided by CUI is believed to be accurate and reliable. However, no responsibility is assumed by CUI for its use, nor for any infringements of patents or other rights of third parties which may result from its use.

CUI products are not authorized or warranted for use as critical components in equipment that requires an extremely high level of reliability. A critical component is any component of a life support device or system whose failure to perform can be reasonably expected to cause the failure of the life support device or system, or to affect its safety or effectiveness.