



Figure similar

Non-reversing motor starter Size 0 Three phase full voltage Solid-state overload relay OLRelay amp range 0.75-3.4A 110-120/220-240VAC 60HZ coil Combination type 3Amp circuit breaker Encl NEMA type 4X 304 S-steel Water/dust tight noncorrosive Extra-wide enclosure

product brand name	Class 18 & 26
design of the product	Full-voltage non-reversing motor starter with motor circuit protector
special product feature	ESP200 overload relay; Dual voltage coil
<b>General technical data</b>	
Height x Width x Depth [in]	24 × 20 × 8 in
touch protection against electrical shock	NA for enclosed products
installation altitude [ft] at height above sea level maximum	6560 ft
ambient temperature [°F]	
• during storage	-22 ... +149 °F
• during operation	-4 ... +104 °F
ambient temperature	
• during storage	-30 ... +65 °C
• during operation	-20 ... +40 °C
<b>Horsepower ratings</b>	
yielded mechanical performance [hp] for 3-phase AC motor	
• at 200/208 V rated value	0.5 hp
• at 220/230 V rated value	0.5 hp
• at 460/480 V rated value	1 hp
• at 575/600 V rated value	1 hp
<b>Contactors</b>	
size of contactor	NEMA controller size 0
number of NO contacts for main contacts	3
operating voltage for main current circuit at AC at 60 Hz maximum	600 V
operational current at AC at 600 V rated value	18 A
mechanical service life (switching cycles) of the main contacts typical	10000000
<b>Auxiliary contact</b>	
number of NC contacts at contactor for auxiliary contacts	0
number of NO contacts at contactor for auxiliary contacts	1
number of total auxiliary contacts maximum	8
contact rating of auxiliary contacts of contactor according to UL	10A@600VAC (A600), 5A@600VDC (P600)
<b>Coil</b>	
type of voltage of the control supply voltage	AC
control supply voltage	
• at AC at 60 Hz rated value	110 ... 240 V
holding power at AC minimum	8.6 W

apparent pick-up power of magnet coil at AC	218 VA
apparent holding power of magnet coil at AC	25 VA
operating range factor control supply voltage rated value of magnet coil	0.85 ... 1.1
percental drop-out voltage of magnet coil related to the input voltage	50 %
ON-delay time	19 ... 29 ms
OFF-delay time	10 ... 24 ms
<b>Overload relay</b>	
reset function	Manual, automatic and remote
trip class	CLASS 5 / 10 / 20 (factory set) / 30
adjustable current response value current of the current-dependent overload release	0.75 ... 3.4 A
make time with automatic start after power failure maximum	3 s
relative repeat accuracy	1 %
number of NC contacts of auxiliary contacts of overload relay	1
number of NO contacts of auxiliary contacts of overload relay	1
operational current of auxiliary contacts of overload relay <ul style="list-style-type: none"> <li>• at AC at 600 V</li> <li>• at DC at 250 V</li> </ul>	5 A 1 A
contact rating of auxiliary contacts of overload relay according to UL	5A@600VAC (B600), 1A@250VDC (R300)
insulation voltage (Ui) <ul style="list-style-type: none"> <li>• with single-phase operation at AC rated value</li> <li>• with multi-phase operation at AC rated value</li> </ul>	600 V 300 V
<b>Enclosure</b>	
degree of protection NEMA rating	4X, 304 stainless steel
design of the housing	dustproof, waterproof & resistant to corrosion
<b>Circuit Breaker</b>	
type of the motor protection	Motor circuit protector (magnetic trip only)
operational current of motor circuit breaker rated value	3 A
adjustable current response value current of instantaneous short-circuit trip unit	10 ... 35 A
<b>Mounting/wiring</b>	
mounting position	Vertical
fastening method	Surface mounting and installation
type of electrical connection for supply voltage line-side	Box lug
type of connectable conductor cross-sections at line-side at AWG cables single or multi-stranded	1x (14 AWG ... 10 AWG) or 1x (12 AWG ... 10 AWG)
temperature of the conductor for supply maximum permissible	75 °C
material of the conductor for supply	AL or CU
type of electrical connection for load-side outgoing feeder	Screw-type terminals
tightening torque [lbf·in] for load-side outgoing feeder	20 ... 24 lbf·in
type of connectable conductor cross-sections at AWG cables for load-side outgoing feeder single or multi-stranded	2x (14 ... 10 AWG)
temperature of the conductor for load-side outgoing feeder maximum permissible	75 °C
material of the conductor for load-side outgoing feeder	CU
type of electrical connection of magnet coil	Screw-type terminals
tightening torque [lbf·in] at magnet coil	5 ... 12 lbf·in
type of connectable conductor cross-sections of magnet coil at AWG cables single or multi-stranded	2x (16 ... 12 AWG)
temperature of the conductor at magnet coil maximum permissible	75 °C
material of the conductor at magnet coil	CU
type of electrical connection for auxiliary contacts	Screw-type terminals
tightening torque [lbf·in] at contactor for auxiliary contacts	10 ... 15 lbf·in
type of connectable conductor cross-sections at contactor	1x (12 AWG), 2x (16 ... 14 AWG), 2x (18 ... 16 AWG)

at AWG cables for auxiliary contacts single or multi-stranded	
temperature of the conductor at contactor for auxiliary contacts maximum permissible	75 °C
material of the conductor at contactor for auxiliary contacts	CU
type of electrical connection at overload relay for auxiliary contacts	Screw-type terminals
tightening torque [lbf-in] at overload relay for auxiliary contacts	7 ... 10 lbf-in
type of connectable conductor cross-sections at overload relay at AWG cables for auxiliary contacts single or multi-stranded	2x (20 ... 14 AWG)
temperature of the conductor at overload relay for auxiliary contacts maximum permissible	75 °C
material of the conductor at overload relay for auxiliary contacts	CU

**Short-circuit current rating**

design of the short-circuit trip	Instantaneous trip circuit breaker
breaking capacity maximum short-circuit current (Icu)	
<ul style="list-style-type: none"> <li>• at 240 V</li> <li>• at 480 V</li> <li>• at 600 V</li> </ul>	100 kA 100 kA 25 kA
certificate of suitability	NEMA ICS 2; UL 508; CSA 22.2, No.14

**Further information**

Industrial Controls - Product Overview (Catalogs, Brochures,...)  
[www.usa.siemens.com/iccatalog](http://www.usa.siemens.com/iccatalog)  
 Industry Mall (Online ordering system)  
<https://mall.industry.siemens.com/mall/en/us/Catalog/product?mfb=US2:18CUB82WA>  
 Service&Support (Manuals, Certificates, Characteristics, FAQs,...)  
<https://support.industry.siemens.com/cs/US/en/ps/US2:18CUB82WA>  
 Image database (product images, 2D dimension drawings, 3D models, device circuit diagrams, EPLAN macros, ...)  
[http://www.automation.siemens.com/bilddb/cax\\_de.aspx?mfb=US2:18CUB82WA&lang=en](http://www.automation.siemens.com/bilddb/cax_de.aspx?mfb=US2:18CUB82WA&lang=en)  
 Certificates/approvals  
<https://support.industry.siemens.com/cs/US/en/ps/US2:18CUB82WA/certificate>

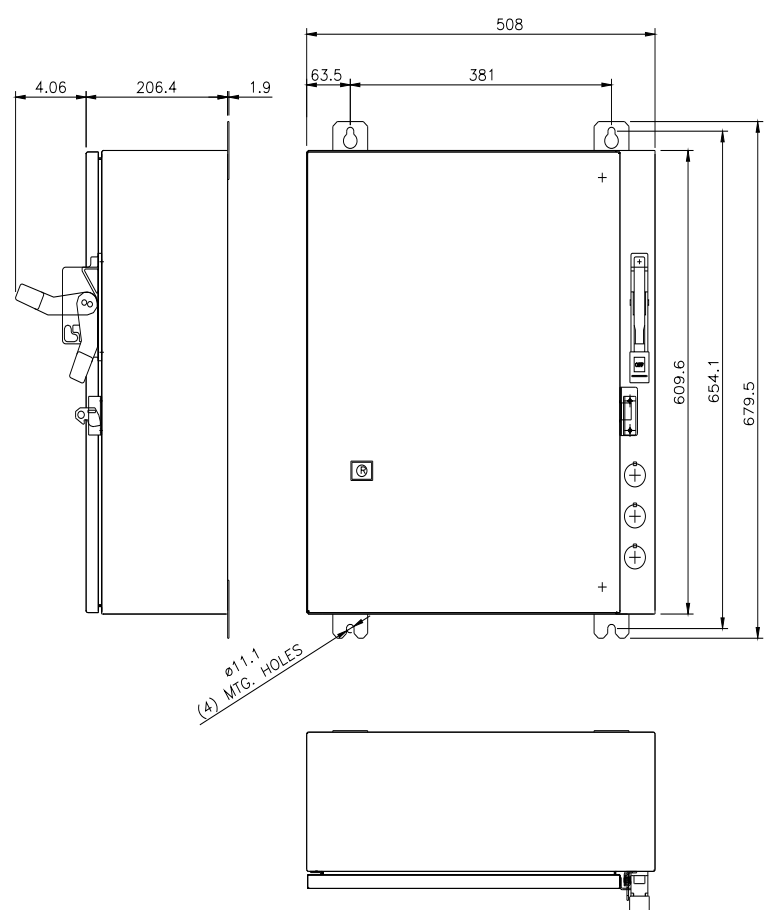

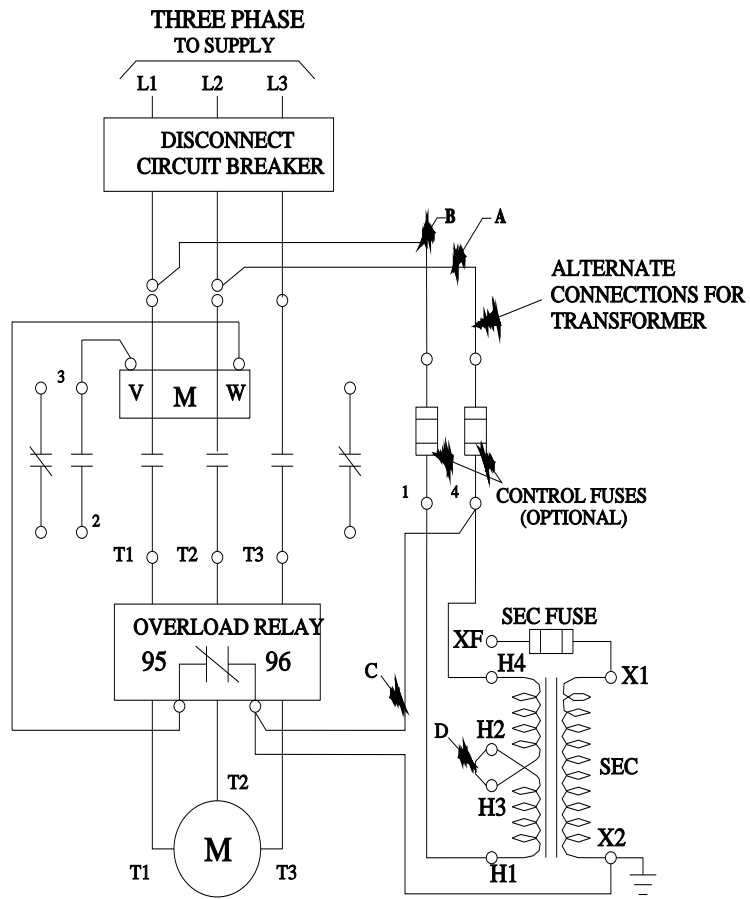

last modified:

1/25/2022