



Figure similar

Non-reversing motor starter, Size 3, Three phase full voltage, Solid-state overload relay, OLRelay amp range 25-100A, 208VAC 60HZ coil, Combination type, 100A non-fusible disconnect, Enclosure NEMA type 1, Indoor general purpose use, Standard width enclosure

product brand name	Class 17 & 25
design of the product	Full-voltage non-reversing motor starter with non-fusible disconnect
special product feature	ESP200 overload relay
General technical data	
Height x Width x Depth [in]	24 × 20 × 8 in
touch protection against electrical shock	(NA for enclosed products)
installation altitude [ft] at height above sea level maximum	6560 ft
ambient temperature [°F]	
• during storage	-22 ... +149 °F
• during operation	-4 ... +104 °F
ambient temperature	
• during storage	-30 ... +65 °C
• during operation	-20 ... +40 °C
Horsepower ratings	
yielded mechanical performance [hp] for 3-phase AC motor	
• at 200/208 V rated value	20 hp
• at 220/230 V rated value	25 hp
• at 460/480 V rated value	50 hp
• at 575/600 V rated value	50 hp
Contactors	
size of contactor	NEMA controller size 3
number of NO contacts for main contacts	3
operational current at AC at 600 V rated value	90 A
mechanical service life (switching cycles) of the main contacts typical	5000000
Auxiliary contact	
number of NC contacts at contactor for auxiliary contacts	0
number of NO contacts at contactor for auxiliary contacts	1
number of total auxiliary contacts maximum	7
contact rating of auxiliary contacts of contactor according to UL	10A@600VAC (A600), 5A@600VDC (P600)
Coil	
type of voltage of the control supply voltage	AC
control supply voltage	
• at AC at 60 Hz rated value	208 V
holding power at AC minimum	14 W
apparent pick-up power of magnet coil at AC	310 VA
apparent holding power of magnet coil at AC	26 VA

operating range factor control supply voltage rated value of magnet coil	0.85 ... 1.1
percental drop-out voltage of magnet coil related to the input voltage	50 %
ON-delay time	26 ... 41 ms
OFF-delay time	14 ... 19 ms

Overload relay

product function	
<ul style="list-style-type: none"> ● overload protection ● phase failure detection ● asymmetry detection ● ground fault detection ● test function ● external reset 	Yes Yes Yes Yes Yes Yes
reset function	Manual, automatic and remote
trip class	CLASS 5 / 10 / 20 (factory set) / 30
adjustable current response value current of the current-dependent overload release	25 ... 100 A
make time with automatic start after power failure maximum	3 s
relative repeat accuracy	1 %
product feature protective coating on printed-circuit board	Yes
number of NC contacts of auxiliary contacts of overload relay	1
number of NO contacts of auxiliary contacts of overload relay	1
operational current of auxiliary contacts of overload relay	
<ul style="list-style-type: none"> ● at AC at 600 V ● at DC at 250 V 	5 A 1 A
contact rating of auxiliary contacts of overload relay according to UL	5A@600VAC (B600), 1A@250VDC (R300)
insulation voltage (Ui)	
<ul style="list-style-type: none"> ● with single-phase operation at AC rated value ● with multi-phase operation at AC rated value 	600 V 300 V

Disconnect Switch

response value of switch disconnecter	100A / 600V
design of fuse holder	non-fusible
operating class of the fuse link	non-fusible

Enclosure

degree of protection NEMA rating	1
design of the housing	indoors, usable on a general basis

Mounting/wiring

mounting position	vertical
fastening method	Surface mounting and installation
type of electrical connection for supply voltage line-side	Box lug
tightening torque [lbf-in] for supply	120 ... 120 lbf-in
temperature of the conductor for supply maximum permissible	75 °C
material of the conductor for supply	AL or CU
type of electrical connection for load-side outgoing feeder	Box lug
tightening torque [lbf-in] for load-side outgoing feeder	120 ... 120 lbf-in
type of connectable conductor cross-sections at AWG cables for load-side outgoing feeder single or multi-stranded	1x (14 ... 2/0 AWG)
temperature of the conductor for load-side outgoing feeder maximum permissible	75 °C
material of the conductor for load-side outgoing feeder	AL or CU
type of electrical connection of magnet coil	Screw-type terminals
tightening torque [lbf-in] at magnet coil	5 ... 12 lbf-in
type of connectable conductor cross-sections of magnet coil at AWG cables single or multi-stranded	2x (16 ... 12 AWG)
temperature of the conductor at magnet coil maximum permissible	75 °C

material of the conductor at magnet coil	CU
type of electrical connection for auxiliary contacts	Screw-type terminals
tightening torque [lbf-in] at contactor for auxiliary contacts	10 ... 15 lbf-in
type of connectable conductor cross-sections at contactor at AWG cables for auxiliary contacts single or multi-stranded	1x (12 AWG), 2x (16 ... 14 AWG), 2x (18 ... 16 AWG)
temperature of the conductor at contactor for auxiliary contacts maximum permissible	75 °C
material of the conductor at contactor for auxiliary contacts	CU
type of electrical connection at overload relay for auxiliary contacts	Screw-type terminals
tightening torque [lbf-in] at overload relay for auxiliary contacts	7 ... 10 lbf-in
type of connectable conductor cross-sections at overload relay at AWG cables for auxiliary contacts single or multi-stranded	2x (20 ... 14 AWG)
temperature of the conductor at overload relay for auxiliary contacts maximum permissible	75 °C
material of the conductor at overload relay for auxiliary contacts	CU

Short-circuit current rating

design of the fuse link for short-circuit protection of the main circuit required	10kA@600V (Class H or K); 100kA@600V (Class R or J)
certificate of suitability	NEMA ICS 2; UL 508; CSA 22.2, No.14

Further information

Industrial Controls - Product Overview (Catalogs, Brochures,...)

www.usa.siemens.com/iccatalog

Industry Mall (Online ordering system)

<https://mall.industry.siemens.com/mall/en/us/Catalog/product?mlfb=US2:17HUG92BD>

Service&Support (Manuals, Certificates, Characteristics, FAQs,...)

<https://support.industry.siemens.com/cs/US/en/ps/US2:17HUG92BD>

Image database (product images, 2D dimension drawings, 3D models, device circuit diagrams, EPLAN macros, ...)

http://www.automation.siemens.com/bilddb/cax_de.aspx?mlfb=US2:17HUG92BD&lang=en

Certificates/approvals

<https://support.industry.siemens.com/cs/US/en/ps/US2:17HUG92BD/certificate>

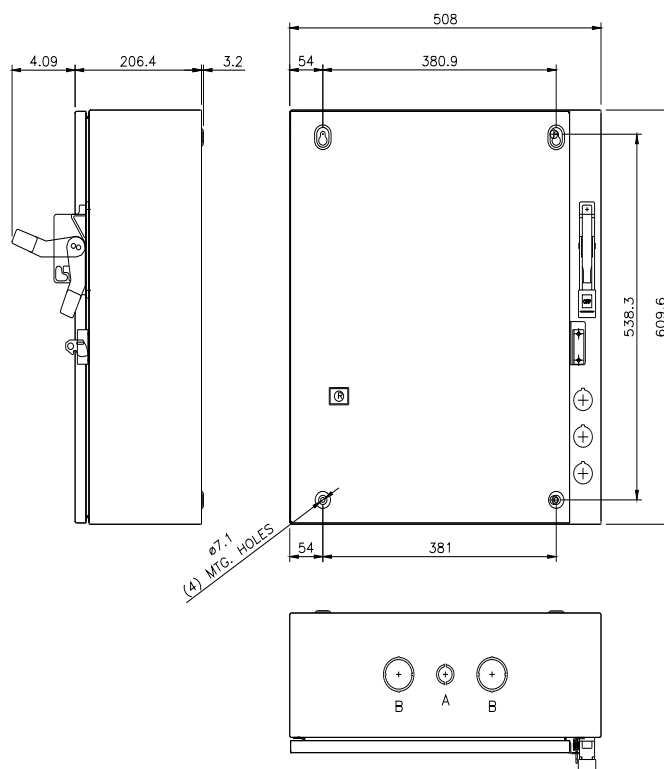

CONDUITS TYP. TOP & BOTTOM

LETTER	CONDUIT SIZE
A	$\phi 12.7$ & $\phi 19$ CONDUIT
B	$\phi 31.8$ & $\phi 38.1$ CONDUIT

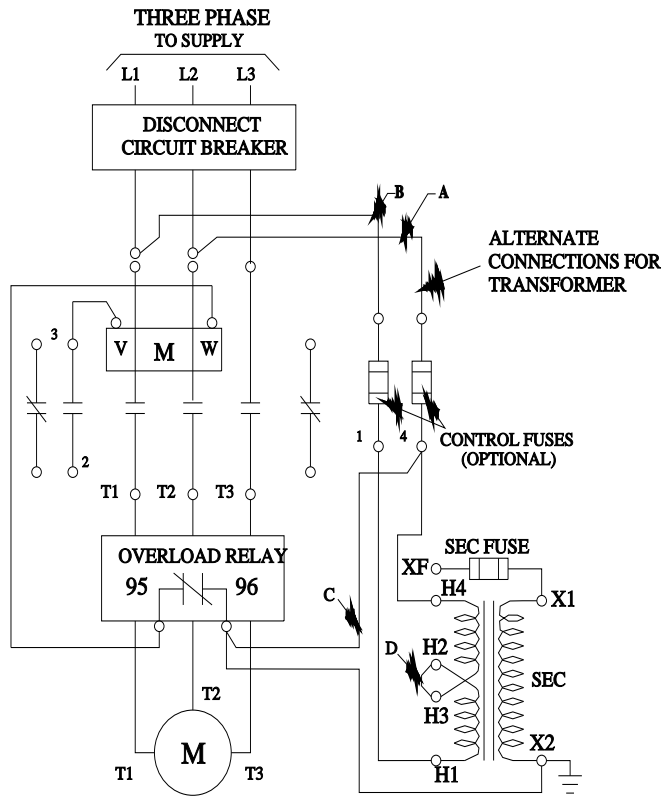

D68782001

last modified:

1/25/2022