



Industrial SD 2.0 Specification

(FxPrem III, SLC)

Version 1.1

Address: 28 Genting Lane, #09-03/04/05 Platinum 28, Singapore 349585

Tel : +65-6493 5035

Fax : +65-6493 5037

Website: <http://www.flexxon.com>

Email: flexxon@flexxon.com

ALL RIGHTS ARE STRICTLY RESERVED. ANY PORTION OF THIS PAPER SHALL NOT BE REPRODUCED, COPIED, OR TRANSLATED TO ANY OTHER FORMS WITHOUT PERMISSION FROM FLEXXON.

Table of Contents

1.	General Description.....	1
1.1.	Introduction.....	1
1.2.	Product Overview	1
2.	Product Specifications.....	3
2.1.	Performance	3
2.2.	Power	3
2.3.	MTBF.....	3
2.4.	Data Retention.....	3
3.	Environmental Specifications	4
4.	Electrical Specifications	5
4.1.	DC Characteristics	5
4.1.1.	Bus Operation Conditions for 3.3V Signaling	5
4.1.2.	Bus Signal Line Load.....	6
4.1.3.	Power Up Time of Host	7
4.1.4.	Power Up Time of Card	8
4.2.	AC Characteristic.....	8
4.2.1.	SD Interface timing (Default)	9
4.2.2.	SD Interface Timing (High-Speed Mode).....	10
5.	Pad Assignment.....	12
5.1.	Pad Assignment and Descriptions.....	12
6.	Registers	13
7.	Physical Dimension	14
8.	Ordering Information.....	15

1. GENERAL DESCRIPTION



1.1. Introduction

FLEXXON Industrial FxPrem III Series SD 2.0 card is data crypto solution which provides low power consumption, good reliability, and wide compatibility. It can alternate communication protocol between SD mode and SPI mode. It's well adapted for hand-held application in industrial/medical markets already.

1.2. Product Overview

- ❖ **Flash**
 - SLC
- ❖ **Capacity**
 - 512MB up to 2GB
- ❖ **Support SD system specification version 2.0**
- ❖ **Support SD SPI mode**
- ❖ **Copyrights Protection Mechanism**
 - Compliant with the highest security of SDMI standard
- ❖ **Support CPRM (Content Protection for Recordable Media) of SD Card**
- ❖ **Card removal during read operation will never harm the content**
- ❖ **Password Protection of cards (optional)**
- ❖ **Write Protect feature using mechanical switch**
- ❖ **Built-in write protection features (permanent and temporary)**
- ❖ **Support Adaptive Wear Leveling**
- ❖ **Sudden Power Loss management**
- ❖ **Temperature Range**
 - Operation (Diamond) : -40°C ~ 85°C
 - Storage: -40°C ~ 85°C
- ❖ **RoHS Compliant**
- ❖ **SMART Function**

❖ **Bus Speed Mode (use 4 parallel data lines)**

▪ **Non-UHS mode**

- Default speed mode: 3.3V signaling, frequency up to 25MHz, up to 12.5MB/sec
- High speed mode: 3.3V signaling, frequency up to 50MHz, up to 25MB/sec

FLEXON CONFIDENTIAL

2. PRODUCT SPECIFICATIONS



2.1. Performance

Table 2-1 Performance of SD (FxPrem III)

Capacity	Sequential	
	Read (MB/s)	Write (MB/s)
512MB	23	17
1GB	23	19
2GB	23	20

NOTES:

1. The performance is obtained from TestMetrix Test (@500MB).
2. Samples are made of SLC NAND Flash.
3. Performance may vary from flash configuration and platform.

2.2. Power

Table 2-2 Max Power Consumption of SD (FxPrem III Low Power)

Capacity	Read (mA)	Write (mA)	Standby (uA)
512MB	40	47	128
1GB	40	48	128
2GB	42	50	138

2.3. MTBF

MTBF, an acronym for Mean Time Between Failures, is a measure of a device's reliability. Its value represents the average time between a repair and the next failure. The higher the MTBF value, the higher the reliability of the device. The predicted result of FLEXXON's FxPrem III Series SD is more than 3,000,000 hours.

2.4. Data Retention

- 10 years if > 90% life remaining (@25C)
- 1 year if < 10% life remaining (@25C)

3. ENVIRONMENTAL SPECIFICATIONS



Test Items	Test Conditions
Storage Temperature	-40°C ~ 85°C
Operating Temperature	-40°C ~ 85°C
Storage Humidity	55°C, 95% RH
Operating Humidity	55°C, 95% RH
Shock	1500G, Half Sin Pulse Duration 0.5ms
Vibration	80Hz ~ 2000Hz/20G, 20Hz ~ 80Hz/1.52mm, 3 axis/30min
Drop	150cm free fall, 6 face of each unit
Bending	≥ 10N, Hold 1 min/5 times
Torque	0.1N-m or +/-2.5 deg, Hold 30 seconds/5 times
Salt Spray	Concentration: 3% NaCl, Temperature: 35°C, 24hours
Waterproof	Water temperature: 25°C Water depth: The lowest point of unit is locating 1000mm below surface. Storage for 30 mins
Switch Cycle	0.4~0.5 N, 1,000 times
Durability	10,000 times
ESD	Contact: +/- 4KV each item 25 times Air: +/- 8KV 10 times

4. ELECTRICAL SPECIFICATIONS



4.1. DC Characteristics

4.1.1. Bus Operation Conditions for 3.3V Signaling

Table 4-1 Threshold Level for High Voltage Range

Parameter	Symbol	Min.	Max	Unit	Condition
Supply Voltage	V_{DD}	2.7	3.6	V	
Output High Voltage	V_{OH}	$0.75 \cdot V_{DD}$		V	$I_{OH} = -2\text{mA}$ V_{DD} Min
Output Low Voltage	V_{OL}		$0.125 \cdot V_{DD}$	V	$I_{OL} = 2\text{mA}$ V_{DD} Min
Input High Voltage	V_{IH}	$0.625 \cdot V_{DD}$	$V_{DD} + 0.3$	V	
Input Low Voltage	V_{IL}	$V_{SS} - 0.3$	$0.25 \cdot V_{DD}$	V	
Power Up Time			250	ms	From 0V to V_{DD} min

Parameter	Symbol	Min.	Max	Unit	Condition
Supply Voltage	V_{DD}	2.7	3.6	V	
Regulator Voltage	V_{DDIO}	1.7	1.95	V	Generated by V_{DD}
Output High Voltage	V_{OH}	1.4	-	V	$I_{OH} = -2\text{mA}$
Output Low Voltage	V_{OL}	-	0.45	V	$I_{OL} = 2\text{mA}$
Input High Voltage	V_{IH}	1.27	2.00	V	
Input Low Voltage	V_{IL}	$V_{SS} - 0.3$	0.58	V	

Parameter	Symbol	Min	Max.	Unit	Remarks
Input Leakage Current		-2	2	μA	DAT3 pull-up is disconnected.

Table 4-2 Peak Voltage and Leakage Current

Parameter	Symbol	Min	Max.	Unit	Remarks
Peak voltage on all lines		-0.3	$V_{DD} + 0.3$	V	
All Inputs					
Input Leakage Current		-10	10	μA	
All Outputs					
Output Leakage Current		-10	10	μA	

4.1.2. Bus Signal Line Load

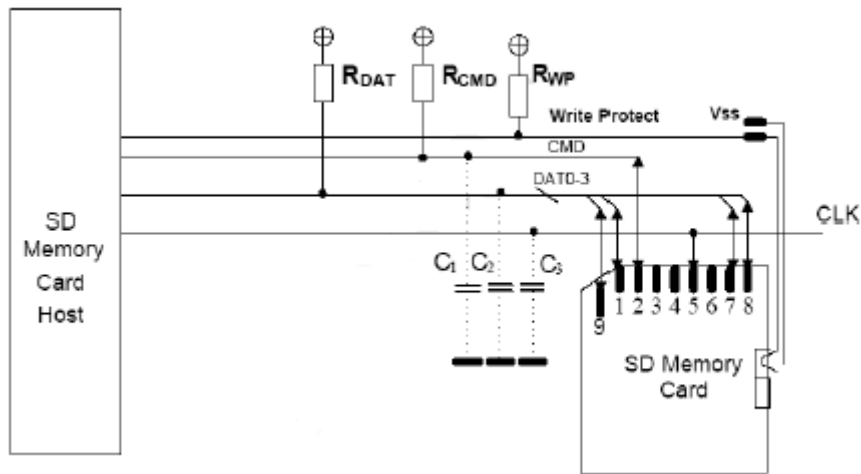

Bus Operation Conditions – Signal Line’s Load

$$\text{Total Bus Capacitance} = C_{\text{HOST}} + C_{\text{BUS}} + N C_{\text{CARD}}$$

Parameter	symbol	Min	Max	Unit	Remark
Pull-up resistance	R_{CMD} R_{DAT}	10	100	k Ω	to prevent bus floating
Total bus capacitance for each signal line	C_L		40	pF	1 card $C_{\text{HOST}}+C_{\text{BUS}}$ shall not exceed 30 pF
Card Capacitance for each signal pin	C_{CARD}		10^1	pF	
Maximum signal line inductance			16	nH	
Pull-up resistance inside card (pin1)	R_{DAT3}	10	90	k Ω	May be used for card detection
Capacity Connected to Power Line	C_C		5	uF	To prevent inrush current

4.1.3. Power Up Time of Host

Host needs to keep power line level less than 0.5V and more than 1ms before power ramp up.

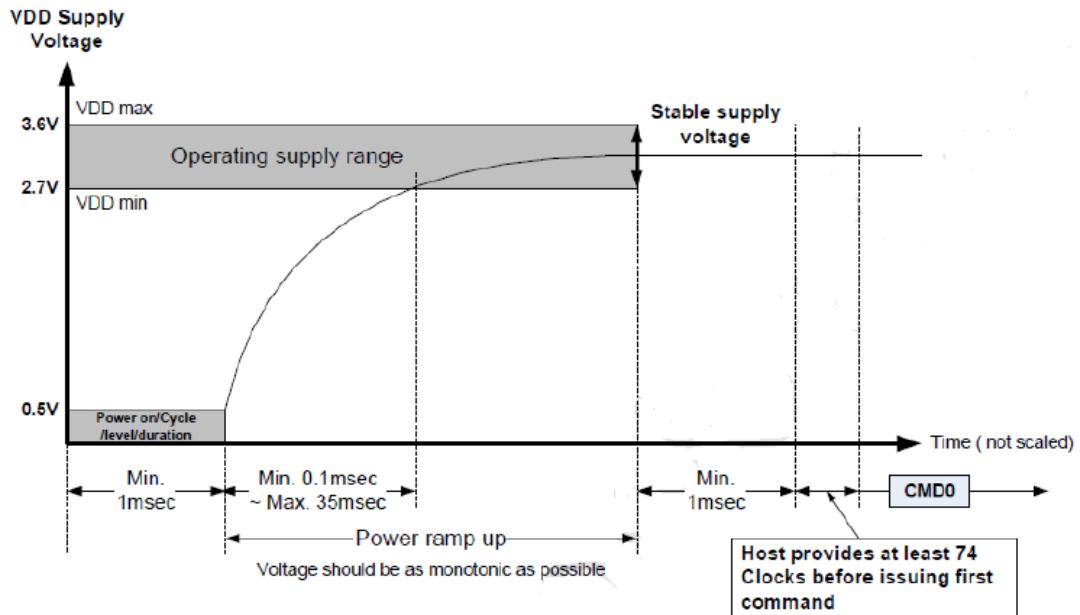

Power On or Power Cycle

Followings are requirements for Power on and Power cycle to assure a reliable SD Card hard reset.

- (1) Voltage level shall be below 0.5V
- (2) Duration shall be at least 1ms.

Power Supply Ramp Up

The power ramp up time is defined from 0.5V threshold level up to the operating supply voltage which is stable between VDD (min.) and VDD (max.) and host can supply SDCLK.

Followings are recommendation of Power ramp up:

- (1) Voltage of power ramp up should be monotonic as much as possible.
- (2) The minimum ramp up time should be 0.1ms.
- (3) The maximum ramp up time should be 35ms for 2.7-3.6V power supply.
- (4) Host shall wait until VDD is stable.
- (5) After 1ms VDD stable time, host provides at least 74 clocks before issuing the first command.

Power Down and Power Cycle

- When the host shuts down the power, the card VDD shall be lowered to less than 0.5Volt for a minimum period of 1ms. During power down, DAT, CMD, and CLK should be disconnected or driven to logical 0 by the host to avoid a situation that the operating current is drawn through the signal lines.
- If the host needs to change the operating voltage, a power cycle is required. Power cycle means the power is turned off and supplied again. Power cycle is also needed for accessing cards that are already in *Inactive State*. To create a power cycle the host shall follow the power down description before power up the card (i.e. the card VDD shall be once lowered to less than 0.5Volt for a minimum period of 1ms).

4.1.4. Power Up Time of Card

A device shall be ready to accept the first command within 1ms from detecting VDD min.

Device may use up to 74 clocks for preparation before receiving the first command.

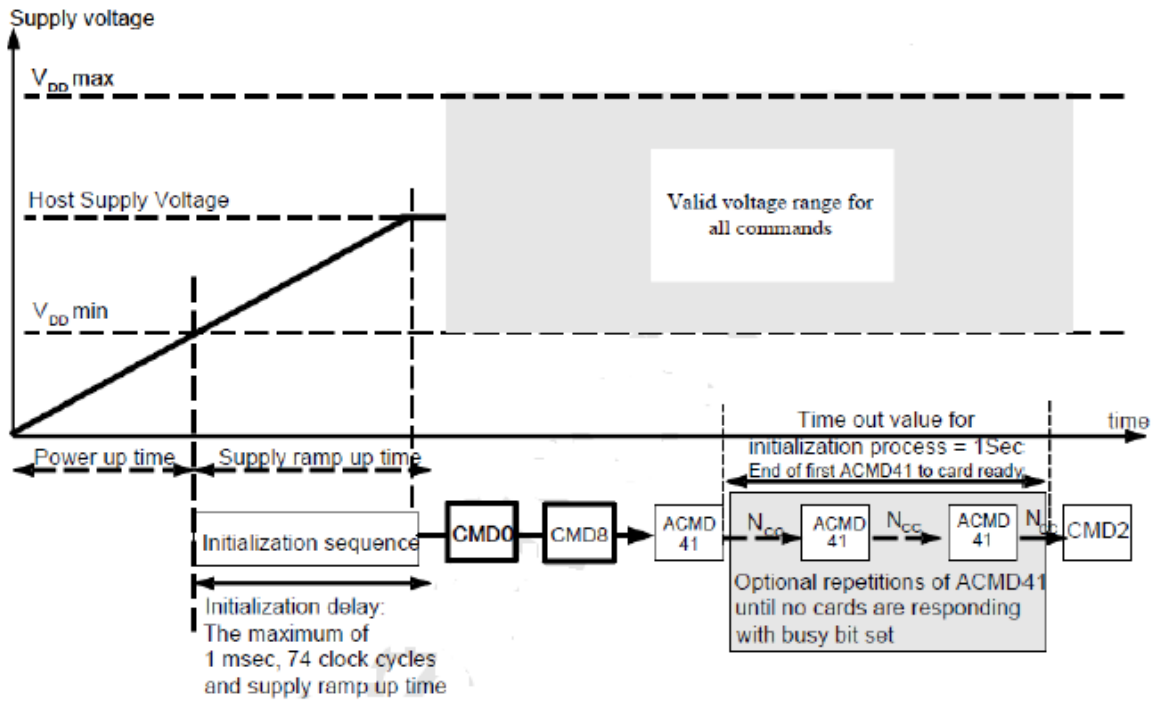

4.2. AC Characteristic

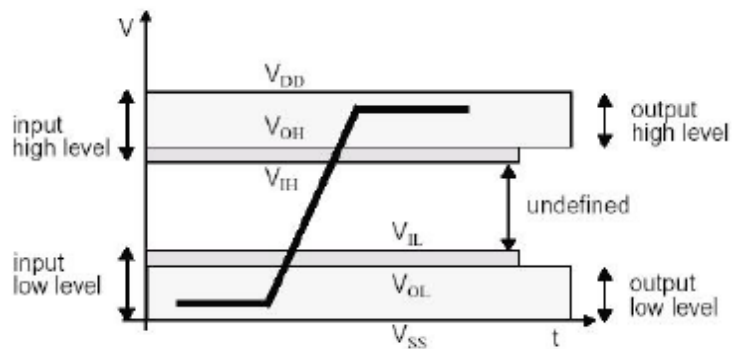

4.2.1. SD Interface timing (Default)

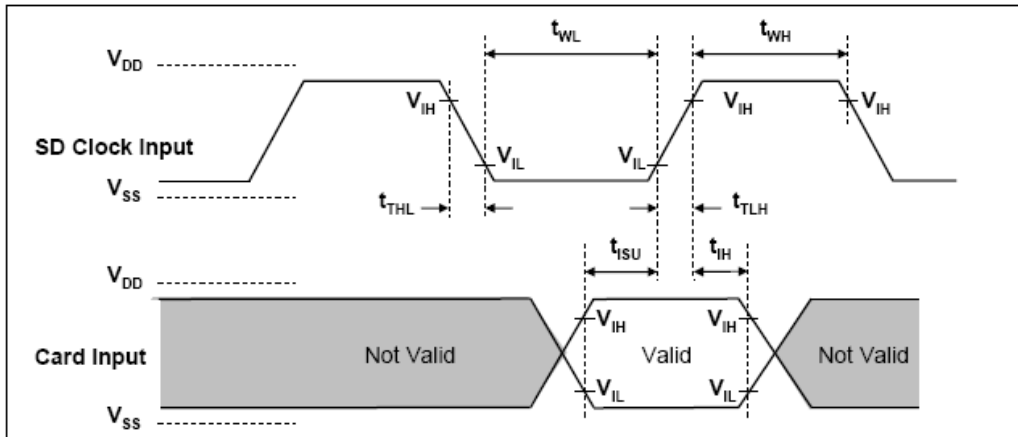

Card Input Timing (Default Speed Card)

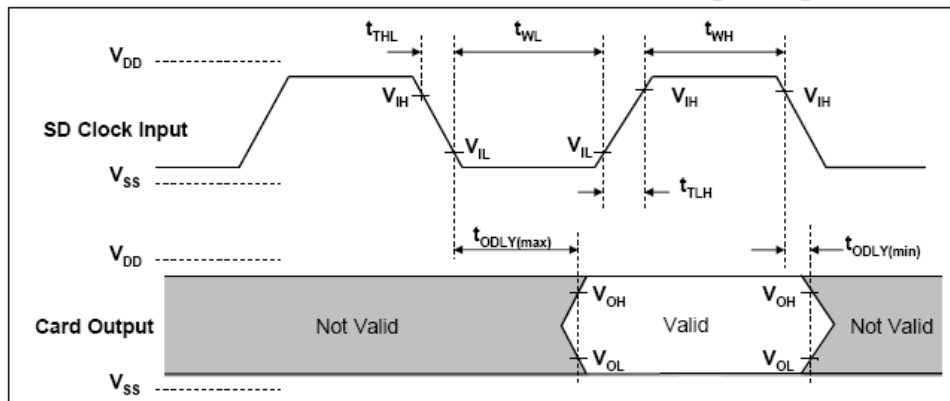

Card Output Timing (Default Speed Mode)

FLEXION

Parameter	Symbol	Min	Max	Unit	Remark
Clock CLK (All values are referred to min(V_{IH}) and max(V_{IL}))					
Clock frequency Data Transfer Mode	f_{PP}	0	25	MHz	$C_{card} \leq 10$ pF (1 card)
Clock frequency Identification Mode	f_{OD}	0 ₍₁₎ /100	400	KHz	$C_{card} \leq 10$ pF (1 card)
Clock low time	t_{WL}	10		ns	$C_{card} \leq 10$ pF (1 card)
Clock high time	t_{WH}	10		ns	$C_{card} \leq 10$ pF (1 card)
Clock rise time	t_{TLH}		10	ns	$C_{card} \leq 10$ pF (1 card)
Clock fall time	t_{THL}		10	ns	$C_{card} \leq 10$ pF (1 card)
Inputs CMD, DAT (referenced to CLK)					
Input set-up time	t_{ISU}	5		ns	$C_{card} \leq 10$ pF (1 card)
Input hold time	t_{IH}	5		ns	$C_{card} \leq 10$ pF (1 card)
Outputs CMD, DAT (referenced to CLK)					
Output Delay time during Data Transfer Mode	t_{ODLY}	0	14	ns	$C_L \leq 40$ pF (1 card)
Output Delay time during Identification Mode	t_{ODLY}	0	50	ns	$C_L \leq 40$ pF (1 card)

(1) 0Hz means to stop the clock. The given minimum frequency range is for cases where continues clock is required.

4.2.2. SD Interface Timing (High-Speed Mode)

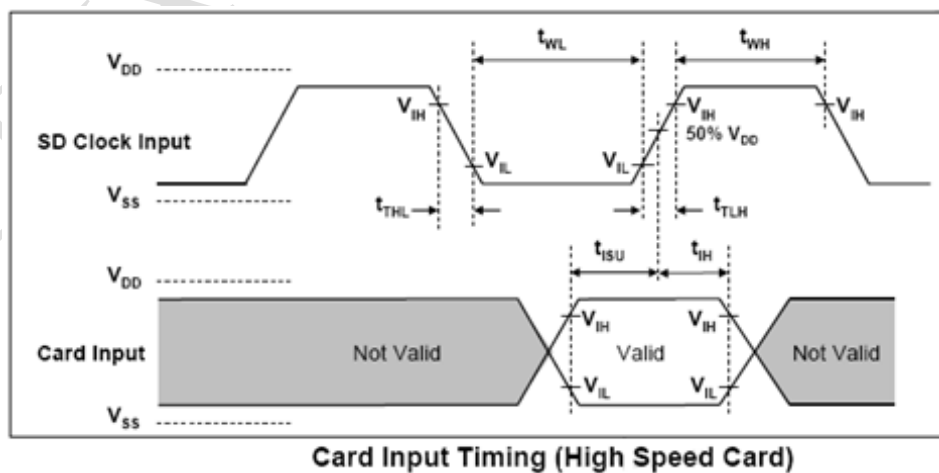

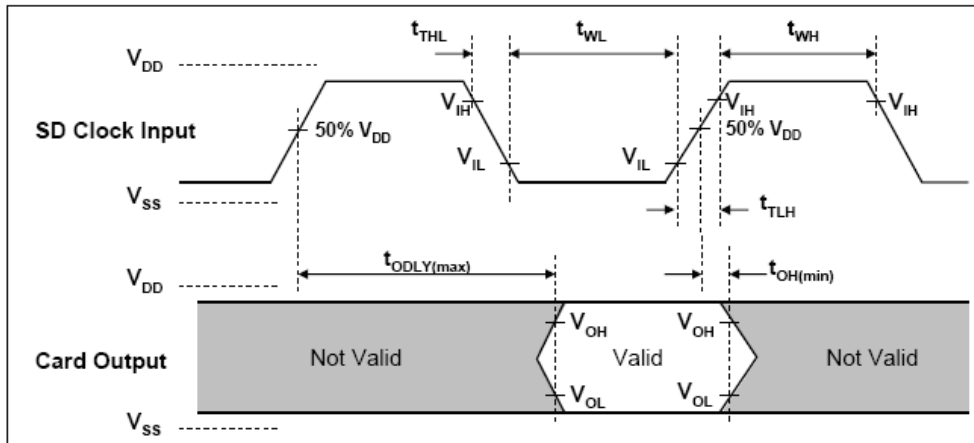

Card Output Timing (High Speed Mode)

Parameter	Symbol	Min	Max	Unit	Remark
Clock CLK (All values are referred to min(V_{IH}) and max(V_{IL}))					
Clock frequency Data Transfer Mode	f _{pp}	0	50	MHz	C _{card} ≤ 10 pF (1 card)
Clock low time	t _{WL}	7		ns	C _{card} ≤ 10 pF (1 card)
Clock high time	t _{WH}	7		ns	C _{card} ≤ 10 pF (1 card)
Clock rise time	t _{TLH}		3	ns	C _{card} ≤ 10 pF (1 card)
Clock fall time	t _{THL}		3	ns	C _{card} ≤ 10 pF (1 card)
Inputs CMD, DAT (referenced to CLK)					
Input set-up time	t _{ISU}	6		ns	C _{card} ≤ 10 pF (1 card)
Input hold time	t _{IH}	2		ns	C _{card} ≤ 10 pF (1 card)
Outputs CMD, DAT (referenced to CLK)					
Output Delay time during Data Transfer Mode	t _{ODLY}		14	ns	C _L ≤ 40 pF (1 card)
Output Hold time	T _{OH}	2.5		ns	C _L ≤ 15 pF (1 card)
Total System capacitance of each line ¹	C _L		40	pF	C _L ≤ 15 pF (1 card)

(1) In order to satisfy severe timing, the host shall drive only one card.

5. PAD ASSIGNMENT



5.1. Pad Assignment and Descriptions

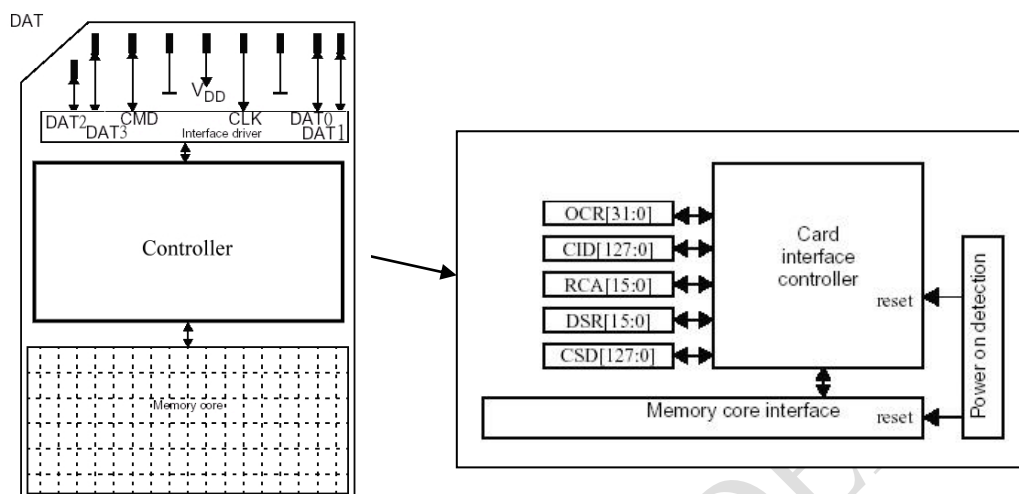

Table 5-1 SD Memory Card Pad Assignment

pin	SD Mode			SPI Mode		
	Name	Type ¹	Description	Name	Type	Description
1	CD/DAT3 ²	I/O/PP ³	Card Detect/ Data Line[bit3]	CS	I ³	Chip Select (net true)
2	CMD	PP	Command/Response	DI	I	Data In
3	V _{SS1}	S	Supply voltage ground	VSS	S	Supply voltage ground
4	V _{DD}	S	Supply voltage	VDD	S	Supply voltage
5	CLK	I	Clock	SCLK	I	Clock
6	V _{SS2}	S	Supply voltage ground	VSS2	S	Supply voltage ground
7	DAT0	I/O/PP	Data Line[bit0]	DO	O/PP	Data Out
8	DAT1	I/O/PP	Data Line[bit1]	RSV		
9	DAT2	I/O/PP	Data Line[bit2]	RSV		

- (1) S: power supply, I: input; O: output using push-pull drivers; PP: I/O using push-pull drivers.
- (2) The extended DAT lines (DAT1-DAT3) are input on power up. They start to operate as DAT lines after SET_BUS_WIDTH command. The Host shall keep its own DAT1-DAT3 lines in input mode as well while they are not used. It is defined so in order to keep compatibility to MultiMedia Cards.
- (3) At power up, this line has a 50KOhm pull up enabled in the card. This resistor serves two functions: Card detection and Mode Selection. For Mode Selection, the host can drive the line high or let it be pulled high to select SD mode. If the host wants to select SPI mode, it should drive the line low. For Card detection, the host detects that the line is pulled high. This pull-up should be disconnected by the user during regular data transfer with SET_CLR_CARD_DETECT (ACMD42) command.

6. REGISTERS



Name	Width	Description
CID	128bit	Card identification number; card individual number for identification.
RCA	16bit	Relative card address; local system address of a card, dynamically suggested by the card and approved by the host during initialization.
DSR	16bit	Driver Stage Register; to configure the card's output drivers.
CSD	128bit	Card Specific Data; Information about the card operation conditions.
SCR	64bit	SD Configuration Register; Information about the SD Memory Card's Special Features capabilities
OCR	32bit	Operation conditions register.
SSR	512bit	SD Status; Information about the card proprietary features.
OCR	32bit	Card Status; Information about the card status.

FLEXXON CONFIDENTIAL

7. PHYSICAL DIMENSION



Dimension: 32mm(L) x 24mm(W) x 2.1mm(H)

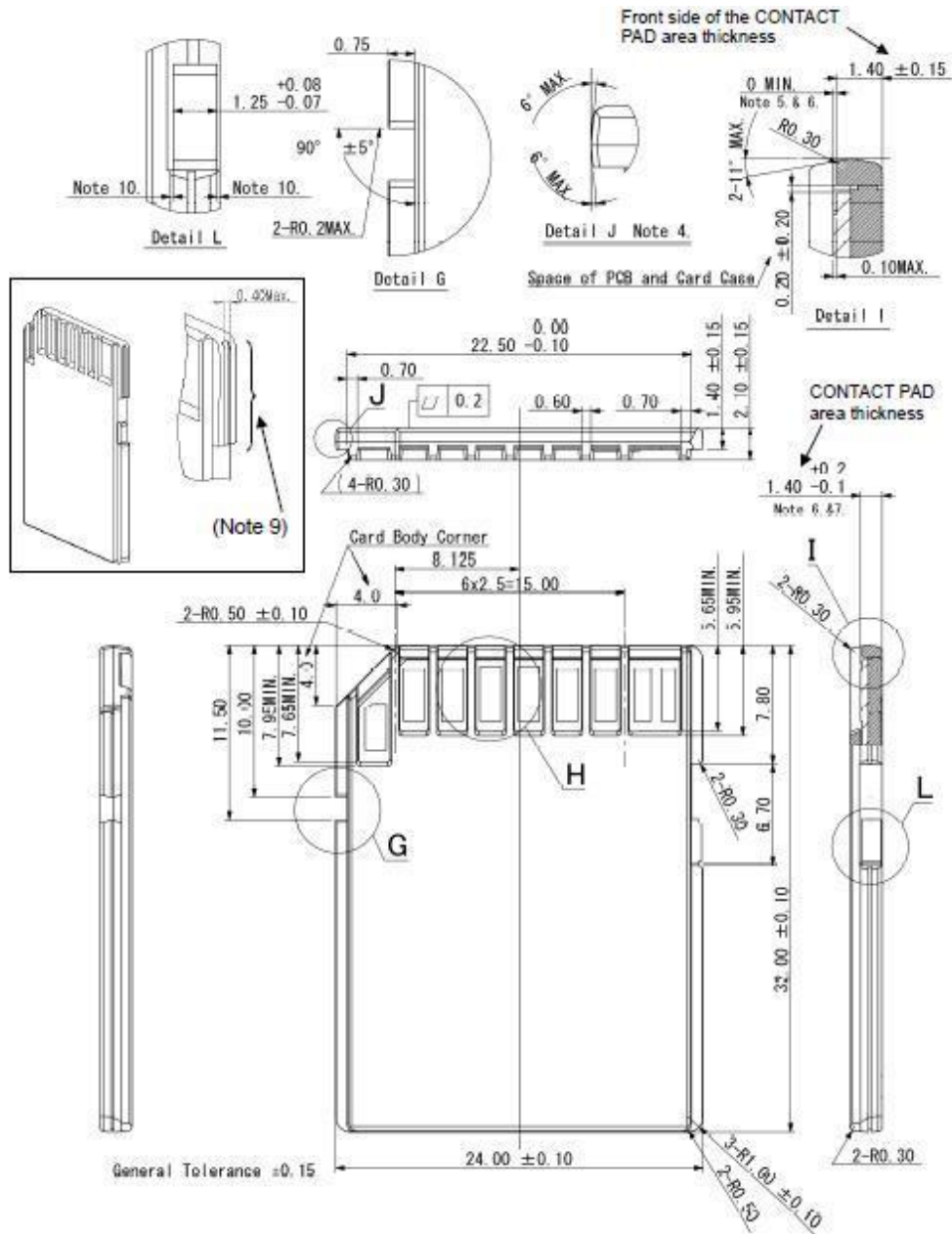

FLEON

8. ORDERING INFORMATION



Capacity	Part Number (Diamond Grade)
512MB	FDMS512MSE-N300
1GB	FDMS001GSE-N300
2GB	FDMS002GSE-N300

FLEXOXON CONFIDENTIAL

Revision History

Revision	Release Date	Description
1.0	2017/10	First release
1.1	2021/11	Add 512MB and 2GB, Update Performance and Power consumption

FLEXXON CONFIDENTIAL