

Low Voltage Detector with SENSE Pin for Industrial Applications

No. EY-261-230801

NOTICE

R3117xxx3A/C may cause the malfunction (miss detection), in the case of its V_{DD} pin voltage changes very rapidly. Please see "Power Supply Injection Order" for details.

OUTLINE

The R3117xxx3 is a voltage detector IC with high detector threshold accuracy and ultra-low supply current, which can be operated at an extremely low voltage and is used for system reset as an example.

The IC consists of a voltage reference unit, a comparator, resistors for detector threshold setting, an output driver and a hysteresis circuit. The detector threshold is fixed with high accuracy internally and does not require any adjustment.

The tolerance of the detector threshold is ± 15 mV ($-V_{DET} \leq 1.5$ V) or $\pm 1.0\%$ (1.5 V $< -V_{DET}$). Since the sense pin is separated from the V_{DD} pin of the IC, therefore, even if the sense pin voltage becomes to 0 V, the output voltage keeps its "L" level.

Two output types, Nch open drain type and CMOS type are available.

Two types of packages, SOT-23-5 and DFN(PL)1010-4, are available.

This is a high-reliability semiconductor device for industrial applications (-Y) that has passed both the screening at high temperature and the reliability test with extended hours.

FEATURES ⁽¹⁾

- Operating Voltage Range (Maximum Rating) 1.0 V to 6.0 V (7.0 V)
- Supply Current Typ. 0.29 μ A ($V_{DD} = 6.0$ V)
Not including the consumption current for SENSE pin.
- Operating Temperature Range -40° C to 105° C
- Detector Threshold Range 0.7 V to 5.0 V (0.1 V step)
- Accuracy Detector Threshold $\pm 1.0\%$ ($-V_{DET} \geq 1.6$ V), ± 15 mV ($-V_{DET} < 1.6$ V)
- Temperature-Drift Coefficient of Detector Threshold Typ. ± 30 ppm/ $^{\circ}$ C
- Output Types Nch Open Drain and CMOS
- Packages DFN(PL)1010-4, SOT-23-5

APPLICATIONS

- Industrial equipments such as FAs and smart meters
- Equipments used under high-temperature conditions such as surveillance camera and vending machine
- Equipments accompanied by self-heating such as motor and lighting

⁽¹⁾ $T_a = 25^{\circ}$ C, unless otherwise noted

R3117xxx3-Y

No. EY-261-230801

SELECTION GUIDE

The detector threshold and the output type for the IC can be selected at the users' request.

Selection Guide

Product Name	Package	Quantity per Reel	Pb Free	Halogen Free
R3117Kxx3*-TR-Y	DFN(PL)1010-4	10,000 pcs	Yes	Yes
R3117Nxx3*-TR-YE	SOT-23-5	3,000 pcs	Yes	Yes

xx: The detector threshold can be designated in the range from 0.7 V (07) to 5.0 V (50) in 0.1 V step.

* : Designation of Output Type
(A) Nch Open Drain
(C) CMOS

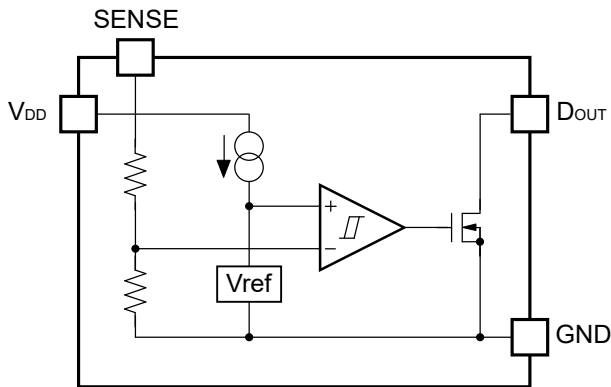
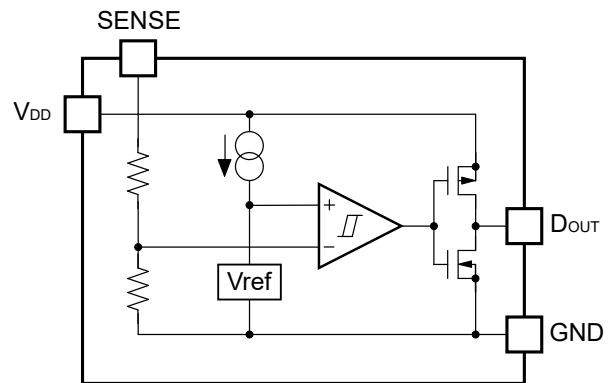
BLOCK DIAGRAMS**Nch Open Drain Output (R3117xxx3A)****CMOS Output (R3117xxx3C)**

PIN DESCRIPTIONS

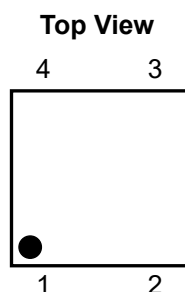

DFN(PL)1010-4 Pin Configuration

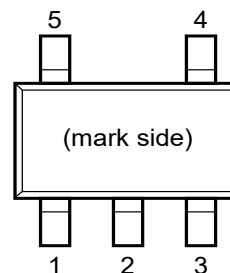
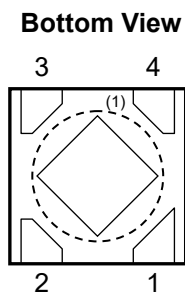

SOT-23-5 Pin Configuration

DFN(PL)1010-4 Pin Descriptions

Pin No.	Symbol	Description
1	D _{OUT}	Output Pin ("L" at detection)
2	SENSE	Voltage Detector Voltage Sense Pin
3	GND	Ground Pin
4	V _{DD}	Input Pin

SOT-23-5 Pin Descriptions

Pin No.	Symbol	Description
1	D _{OUT}	Output Pin ("L" at detection)
2	V _{DD}	Input Pin
3	GND	Ground Pin
4	NC	No Connection
5	SENSE	Voltage Detector Voltage Sense Pin

⁽¹⁾ Tab is GND level (They are connected to the reverse side of this IC). The tab is better to be connected to the GND, but leaving it open is also acceptable.

ABSOLUTE MAXIMUM RATINGS

Absolute Maximum Ratings

Symbol	Item		Rating	Unit	
V_{DD}	Supply Voltage		7.0	V	
V_{SENSE}	SENSE Pin Voltage		7.0	V	
V_{OUT}	Output Voltage (Nch Open Drain Output)		$V_{SS} - 0.3$ to 7.0	V	
	Output Voltage (CMOS Output)		$V_{SS} - 0.3$ to $V_{DD} + 0.3$		
I_{OUT}	Output Current		20	mA	
P_D	Power Dissipation ⁽¹⁾	DFN(PL)1010-4	JEDEC STD. 51-7 Test Land Pattern	800	mW
		SOT-23-5	JEDEC STD. 51-7 Test Land Pattern	660	mW
T_j	Junction Temperature Range		-40 to 125	°C	
T_{stg}	Storage Temperature Range		-55 to 125	°C	

ABSOLUTE MAXIMUM RATINGS

Electronic and mechanical stress momentarily exceeded absolute maximum ratings may cause the permanent damages and may degrade the life time and safety for both device and system using the device in the field. The functional operation at or over these absolute maximum ratings are not assured.

RECOMMENDED OPERATING CONDITIONS

Recommended Operating Conditions

Symbol	Item	Rating	Unit
V_{DD}	Supply Voltage	1.0 to 6.0	V
T_a	Operating Temperature Range	-40 to 105	°C

RECOMMENDED OPERATING CONDITIONS

All of electronic equipment should be designed that the mounted semiconductor devices operate within the recommended operating conditions. The semiconductor devices cannot operate normally over the recommended operating conditions, even if when they are used over such conditions by momentary electronic noise or surge. And the semiconductor devices may receive serious damage when they continue to operate over the recommended operating conditions.

⁽¹⁾ Refer to *POWER DISSIPATION* for detailed information.

ELECTRICAL CHARACTERISTICS

The specifications surrounded by are guaranteed by design engineering at $-40^{\circ}\text{C} \leq T_a \leq 105^{\circ}\text{C}$.

Electrical Characteristics R3117xxx3A/C

($T_a = 25^{\circ}\text{C}$)

Symbol	Item	Conditions	Min.	Typ.	Max.	Unit	
$-V_{\text{DET}}$	Detector Threshold ($T_a = 25^{\circ}\text{C}$)	$0.7\text{ V} \leq -V_{\text{DET}} < 1.6\text{ V}$	$1.0\text{ V} \leq V_{\text{DD}} \leq 5.25\text{ V}$	$-V_{\text{DET}} - 15$		$-V_{\text{DET}} + 15$	mV
			$5.25\text{ V} < V_{\text{DD}} \leq 6.0\text{ V}$	$-V_{\text{DET}} - 11$		$-V_{\text{DET}} + 24$	
		$1.6\text{ V} \leq -V_{\text{DET}} \leq 5.0\text{ V}$	$1.0\text{ V} \leq V_{\text{DD}} \leq 5.25\text{ V}$	$-V_{\text{DET}} \times 0.99$		$-V_{\text{DET}} \times 1.01$	V
			$5.25\text{ V} < V_{\text{DD}} \leq 6.0\text{ V}$	$-V_{\text{DET}} \times 0.9925$		$-V_{\text{DET}} \times 1.016$	
	Detector Threshold ($-40^{\circ}\text{C} \leq T_a \leq 105^{\circ}\text{C}$)	$0.7\text{ V} \leq -V_{\text{DET}} < 1.6\text{ V}$	$1.0\text{ V} \leq V_{\text{DD}} \leq 5.25\text{ V}$	$-V_{\text{DET}} - 30$		$-V_{\text{DET}} + 30$	mV
			$5.25\text{ V} < V_{\text{DD}} \leq 6.0\text{ V}$	$-V_{\text{DET}} - 26$		$-V_{\text{DET}} + 39$	
		$1.6\text{ V} \leq -V_{\text{DET}} \leq 5.0\text{ V}$	$1.0\text{ V} \leq V_{\text{DD}} \leq 5.25\text{ V}$	$-V_{\text{DET}} \times 0.98$		$-V_{\text{DET}} \times 1.02$	V
			$5.25\text{ V} < V_{\text{DD}} \leq 6.0\text{ V}$	$-V_{\text{DET}} \times 0.9825$		$-V_{\text{DET}} \times 1.026$	
V_{HYS}	Detector Threshold Hysteresis	$V_{\text{DD}} = 1.0\text{ to }6.0\text{ V}$	$-V_{\text{DET}} \times 0.04$		$-V_{\text{DET}} \times 0.07$	V	
I_{SS}	Supply Current ⁽¹⁾	$V_{\text{SENSE}} = -V_{\text{DET}} - 0.1\text{ V}$		0.31	1.47	μA	
		$V_{\text{SENSE}} = -V_{\text{DET}} \times 1.1$		0.29	1.25		
R_{SENSE}	Sense Resistor	$-V_{\text{DET}} < 1.5\text{ V}$	6	25		M Ω	
		$1.5\text{ V} \leq -V_{\text{DET}} < 4.7\text{ V}$	5	40			
		$4.7\text{ V} \leq -V_{\text{DET}}$	10	40			
V_{DDL}	Minimum Operating Voltage ⁽²⁾	$T_a = 25^{\circ}\text{C}$			0.50	V	
		$-40^{\circ}\text{C} \leq T_a \leq 105^{\circ}\text{C}$			0.55		

All of unit are tested and specified under load conditions such that $T_j \approx T_a = 25^{\circ}\text{C}$ except for Detector Output Delay Time and Release Output Delay Time.

(1) Consumption current through SENSE pin is not included.

(2) In case that the V_{DD} pin and SENSE pin are connected and the value shows the minimum supply voltage (V_{DD}) when the output voltage at detector threshold can be maintained as 0.1 V or less. (In case of Nch open drain type, pull-up resistor is 470 k Ω and pull-up voltage is set at 5 V for testing). If V_{DD} is high enough, down to 0 V is acceptable for SENSE pin.

ELECTRICAL CHARACTERISTICS (continued)

The specifications surrounded by are guaranteed by design engineering at $-40^{\circ}\text{C} \leq T_a \leq 105^{\circ}\text{C}$.

Electrical Characteristics R3117xxx3A/C

($T_a = 25^{\circ}\text{C}$)

Symbol	Item	Conditions		Min.	Typ.	Max.	Unit	
I_{OUT}	Output Current (Driver Output Pin)	Nch	$V_{\text{DD}} = 0.6 \text{ V}, V_{\text{DS}} = 0.05 \text{ V}$		7			μA
			$-V_{\text{DET}} < 1.1 \text{ V}$	$V_{\text{DD}} = 0.6 \text{ V}$ $V_{\text{DS}} = 0.5 \text{ V}$	0.020			mA
			$1.1 \text{ V} \leq -V_{\text{DET}} < 1.6 \text{ V}$	$V_{\text{DD}} = 1.0 \text{ V}$ $V_{\text{DS}} = 0.5 \text{ V}$	0.400			
			$1.6 \text{ V} \leq -V_{\text{DET}} < 3.1 \text{ V}$	$V_{\text{DD}} = 1.5 \text{ V}$ $V_{\text{DS}} = 0.5 \text{ V}$	1.000			
			$3.1 \text{ V} \leq -V_{\text{DET}}$	$V_{\text{DD}} = 3.0 \text{ V}$ $V_{\text{DS}} = 0.5 \text{ V}$	2.400			
		Pch ⁽¹⁾	$-V_{\text{DET}} < 4.0 \text{ V}$	$V_{\text{DD}} = 4.5 \text{ V}$ $V_{\text{DS}} = 2.1 \text{ V}$	0.650			mA
			$4.0 \text{ V} \leq -V_{\text{DET}}$	$V_{\text{DD}} = 6.0 \text{ V}$ $V_{\text{DS}} = 2.1 \text{ V}$	0.900			
I_{LEAK}	Nch Driver Leakage Current ⁽²⁾	$V_{\text{DD}} = 6.0 \text{ V}, V_{\text{DS}} = 7.0 \text{ V}$				140	nA	
t_{PHL}	Detector Output Delay Time ⁽³⁾	$V_{\text{DD}} = 5 \text{ V}$	$-V_{\text{DET}} < 1.5 \text{ V}$		80		μs	
			$1.5 \text{ V} \leq -V_{\text{DET}}$		40			
t_{PLH}	Release Output Delay Time ⁽³⁾	$V_{\text{DD}} = 5 \text{ V}$	$-V_{\text{DET}} < 4.5 \text{ V}$		50		μs	
			$4.5 \text{ V} \leq -V_{\text{DET}}$		100			

All of unit are tested and specified under load conditions such that $T_j \approx T_a = 25^{\circ}\text{C}$ except for Detector Output Delay Time and Release Output Delay Time.

⁽¹⁾ In case of CMOS type

⁽²⁾ In case of Nch Open Drain type

⁽³⁾ In the case of CMOS output type:

Time interval from forcing pulsive 6.0 V to $-V_{\text{DET}} - 2.0 \text{ V}$ or 0 V, or from forcing 0 V to $-V_{\text{DET}} + 2.0 \text{ V}$ or 6.0 V to SENSE pin, to when the output voltage will reach $V_{\text{DD}}/2$.

In the case of Nch Open drain output type:

Output pin is pulled up to 5 V with 470 k Ω and time interval from forcing 6.0 V to $-V_{\text{DET}} - 2.0 \text{ V}$ or 0 V, or forcing pulsive 0 V to $-V_{\text{DET}} + 2.0 \text{ V}$ or 6.0 V to when the output voltage reaches up to 2.5 V.

Bold values are checked and guaranteed by design engineering at $-40^{\circ}\text{C} \leq T_a \leq 105^{\circ}\text{C}$, unless otherwise noted.

R3117N073A/C to R3117N503A/C

(Ta = 25°C)

Product Number	Detector Threshold 1.0 V ≤ V _{DD} ≤ 5.25 V		Detector Threshold 1.0 V ≤ V _{DD} ≤ 5.25 V		Detector Threshold 5.25 V < V _{DD} ≤ 6.0 V		Detector Threshold 5.25 V < V _{DD} ≤ 6.0 V		Detector Threshold Hysteresis	
	-V _{DET} [V]		-V _{DET} [V]		-V _{DET} [V]		-V _{DET} [V]		V _{HYS} [V]	
	Min.	Max.	Min.	Max.	Min.	Max.	Min.	Max.	Min.	Max.
R3117x073A/C	0.6850	0.7150	0.6700	0.7300	0.6890	0.7240	0.6740	0.7390	0.028	0.049
R3117x083A/C	0.7850	0.8150	0.7700	0.8300	0.7890	0.8240	0.7740	0.8390	0.032	0.056
R3117x093A/C	0.8850	0.9150	0.8700	0.9300	0.8890	0.9240	0.8740	0.9390	0.036	0.063
R3117x103A/C	0.9850	1.0150	0.9700	1.0300	0.9890	1.0240	0.9740	1.0390	0.040	0.070
R3117x113A/C	1.0850	1.1150	1.0700	1.1300	1.0890	1.1240	1.0740	1.1390	0.044	0.077
R3117x123A/C	1.1850	1.2150	1.1700	1.2300	1.1890	1.2240	1.1740	1.2390	0.048	0.084
R3117x133A/C	1.2850	1.3150	1.2700	1.3300	1.2890	1.3240	1.2740	1.3390	0.052	0.091
R3117x143A/C	1.3850	1.4150	1.3700	1.4300	1.3890	1.4240	1.3740	1.4390	0.056	0.098
R3117x153A/C	1.4850	1.5150	1.4700	1.5300	1.4890	1.5240	1.4740	1.5390	0.060	0.105
R3117x163A/C	1.5840	1.6160	1.5680	1.6320	1.5880	1.6256	1.5720	1.6416	0.064	0.112
R3117x173A/C	1.6830	1.7170	1.6660	1.7340	1.6872	1.7272	1.6702	1.7442	0.068	0.119
R3117x183A/C	1.7820	1.8180	1.7640	1.8360	1.7865	1.8288	1.7685	1.8468	0.072	0.126
R3117x193A/C	1.8810	1.9190	1.8620	1.9380	1.8857	1.9304	1.8667	1.9494	0.076	0.133
R3117x203A/C	1.9800	2.0200	1.9600	2.0400	1.9850	2.0320	1.9650	2.0520	0.080	0.140
R3117x213A/C	2.0790	2.1210	2.0580	2.1420	2.0842	2.1336	2.0632	2.1546	0.084	0.147
R3117x223A/C	2.1780	2.2220	2.1560	2.2440	2.1835	2.2352	2.1615	2.2572	0.088	0.154
R3117x233A/C	2.2770	2.3230	2.2540	2.3460	2.2827	2.3368	2.2597	2.3598	0.092	0.161
R3117x243A/C	2.3760	2.4240	2.3520	2.4480	2.3820	2.4384	2.3580	2.4624	0.096	0.168
R3117x253A/C	2.4750	2.5250	2.4500	2.5500	2.4812	2.5400	2.4562	2.5650	0.100	0.175
R3117x263A/C	2.5740	2.6260	2.5480	2.6520	2.5805	2.6416	2.5545	2.6676	0.104	0.182
R3117x273A/C	2.6730	2.7270	2.6460	2.7540	2.6797	2.7432	2.6527	2.7702	0.108	0.189
R3117x283A/C	2.7720	2.8280	2.7440	2.8560	2.7790	2.8448	2.7510	2.8728	0.112	0.196
R3117x293A/C	2.8710	2.9290	2.8420	2.9580	2.8782	2.9464	2.8492	2.9754	0.116	0.203
R3117x303A/C	2.9700	3.0300	2.9400	3.0600	2.9775	3.0480	2.9475	3.0780	0.120	0.210
R3117x313A/C	3.0690	3.1310	3.0380	3.1620	3.0767	3.1496	3.0457	3.1806	0.124	0.217
R3117x323A/C	3.1680	3.2320	3.1360	3.2640	3.1760	3.2512	3.1440	3.2832	0.128	0.224
R3117x333A/C	3.2670	3.3330	3.2340	3.3660	3.2752	3.3528	3.2422	3.3858	0.132	0.231
R3117x343A/C	3.3660	3.4340	3.3320	3.4680	3.3745	3.4544	3.3405	3.4884	0.136	0.238
R3117x353A/C	3.4650	3.5350	3.4300	3.5700	3.4737	3.5560	3.4387	3.5910	0.140	0.245
R3117x363A/C	3.5640	3.6360	3.5280	3.6720	3.5730	3.6576	3.5370	3.6936	0.144	0.252
R3117x373A/C	3.6630	3.7370	3.6260	3.7740	3.6722	3.7592	3.6352	3.7962	0.148	0.259
R3117x383A/C	3.7620	3.8380	3.7240	3.8760	3.7715	3.8608	3.7335	3.8988	0.152	0.266
R3117x393A/C	3.8610	3.9390	3.8220	3.9780	3.8707	3.9624	3.8317	4.0014	0.156	0.273
R3117x403A/C	3.9600	4.0400	3.9200	4.0800	3.9700	4.0640	3.9300	4.1040	0.160	0.280
R3117x413A/C	4.0590	4.1410	4.0180	4.1820	4.0692	4.1656	4.0282	4.2066	0.164	0.287
R3117x423A/C	4.1580	4.2420	4.1160	4.2840	4.1685	4.2672	4.1265	4.3092	0.168	0.294
R3117x433A/C	4.2570	4.3430	4.2140	4.3860	4.2677	4.3688	4.2247	4.4118	0.172	0.301
R3117x443A/C	4.3560	4.4440	4.3120	4.4880	4.3670	4.4704	4.3230	4.5144	0.176	0.308
R3117x453A/C	4.4550	4.5450	4.4100	4.5900	4.4662	4.5720	4.4212	4.6170	0.180	0.315
R3117x463A/C	4.5540	4.6460	4.5080	4.6920	4.5655	4.6736	4.5195	4.7196	0.184	0.322
R3117x473A/C	4.6530	4.7470	4.6060	4.7940	4.6647	4.7752	4.6177	4.8222	0.188	0.329
R3117x483A/C	4.7520	4.8480	4.7040	4.8960	4.7640	4.8768	4.7160	4.9248	0.192	0.336
R3117x493A/C	4.8510	4.9490	4.8020	4.9980	4.8632	4.9784	4.8142	5.0274	0.196	0.343
R3117x503A/C	4.9500	5.0500	4.9000	5.1000	4.9625	5.0800	4.9125	5.1300	0.200	0.350

R3117xxx3-Y

No. EY-261-230801

Product Number	Sense Resistor		Nch Driver Output Current 1		Nch Driver Output Current2		Pch Driver Output Current		Detector Output Delay Time		Release Output Delay Time	
	RSENSE [MΩ]		IOUT1 [μA]		IOUT2 [mA]		IOUT3 [mA]		tPHL [μs]		tPLH [μs]	
	Min.	Typ.	Cond.	Min	Cond.	Min.	Cond.	Min.	Cond.	Typ.	Cond.	Typ.
R3117x073A/C	6	25			V _{DD} = 0.6 V	0.020			V _{DD} = 5.0 V	80		
R3117x083A/C												
R3117x093A/C												
R3117x103A/C												
R3117x113A/C												
R3117x123A/C												
R3117x133A/C												
R3117x143A/C												
R3117x153A/C	5	40	V _{DD} = 0.6 V V _{DS} = 0.05 V	7	V _{DD} = 1.0 V	0.400			V _{SENSE} = 6.0 V ↓ 0 V (1)			
R3117x163A/C												
R3117x173A/C												
R3117x183A/C												
R3117x193A/C												
R3117x203A/C												
R3117x213A/C												
R3117x223A/C												
R3117x233A/C												
R3117x243A/C												
R3117x253A/C												
R3117x263A/C												
R3117x273A/C												
R3117x283A/C												
R3117x293A/C												
R3117x303A/C												
R3117x313A/C												
R3117x323A/C												
R3117x333A/C												
R3117x343A/C												
R3117x353A/C												
R3117x363A/C												
R3117x373A/C												
R3117x383A/C												
R3117x393A/C												
R3117x403A/C												
R3117x413A/C												
R3117x423A/C												
R3117x433A/C												
R3117x443A/C												
R3117x453A/C												
R3117x463A/C												
R3117x473A/C	10				V _{DD} = 3.0 V	2.400			V _{DD} = 5.0 V V _{SENSE} = 6.0 V ↓ -V _{DET} -2.0 V (1)			
R3117x483A/C												
R3117x493A/C												
R3117x503A/C												
R3117x443A/C					V _{DD} = 6.0 V	0.900			V _{DD} = 5.0 V V _{SENSE} = 0 V ↓ 6.0 V (1)			100
R3117x453A/C												
R3117x463A/C												
R3117x473A/C												

(1) 1. In the case of CMOS output type: Time interval from forcing pulsive 6.0 V to -V_{DET} - 2.0 V or 0 V, or from forcing 0 V to -V_{DET} + 2.0 V or 6.0 V to SENSE pin, to when the output voltage will reach V_{DD}/2.

2. In the case of Nch Open drain output type: Output pin is pulled up to 5 V with 470 kΩ and time interval from forcing 6.0 V to -V_{DET} - 2.0 V or 0 V, or forcing pulsive 0 V to -V_{DET} + 2.0 V or 6.0 V to when the output voltage reaches up to 2.5 V.

THEORY OF OPERATION

R3117xxx3A

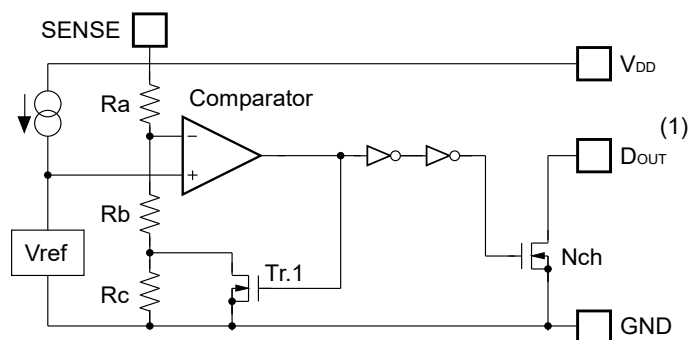

Block Diagram (R3117xxx3A)

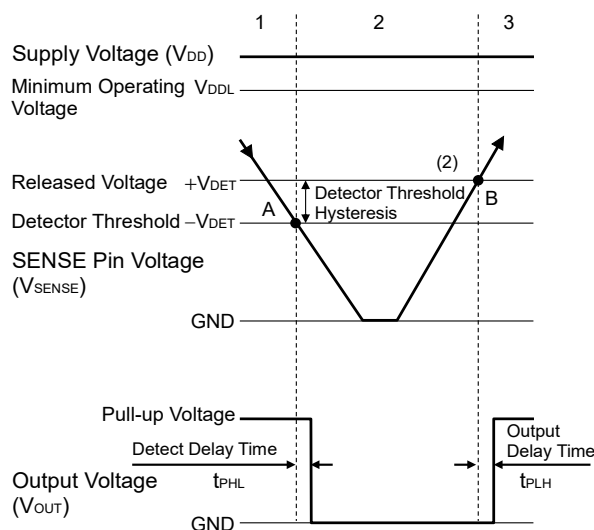

Step	1	2	3
Comparator (-) Pin Input Voltage	I	II	I
Comparator Output	L	H	L
Tr.1	OFF	ON	OFF
Output Tr.	Nch	OFF	ON

$$I \quad \frac{R_b + R_c}{R_a + R_b + R_c} \times V_{SENSE}$$

$$II \quad \frac{R_b}{R_a + R_b} \times V_{SENSE}$$

Operation Diagram

Explanation

Step 1. The output voltage is equal to the pull-up voltage.

Step 2. At Point "A", $V_{ref} \geq V_{SENSE} \times (R_b + R_c) / (R_a + R_b + R_c)$ is true, as a result, the output of comparator is reversed from "L" to "H", therefore the output voltage becomes the GND level. The voltage level of Point A means a detector threshold voltage ($-V_{DET}$). (When the supply voltage is lower than the minimum operating voltage, the operation of the output transistor becomes indefinite. The output voltage is equal to the GND level).

Step 3. At Point "B", $V_{ref} \leq V_{SENSE} \times R_b / (R_a + R_b)$ is true, as a result, the output of comparator is reversed from "H" to "L", then the output voltage is equal to the pull-up voltage. The voltage level of Point B means a released voltage ($+V_{DET}$).

(1) D_{OUT} pin should be pulled-up to V_{DD} or an external voltage level.

(2) The difference between a released voltage and a detector threshold voltage is a detector threshold hysteresis.

R3117xxxxC

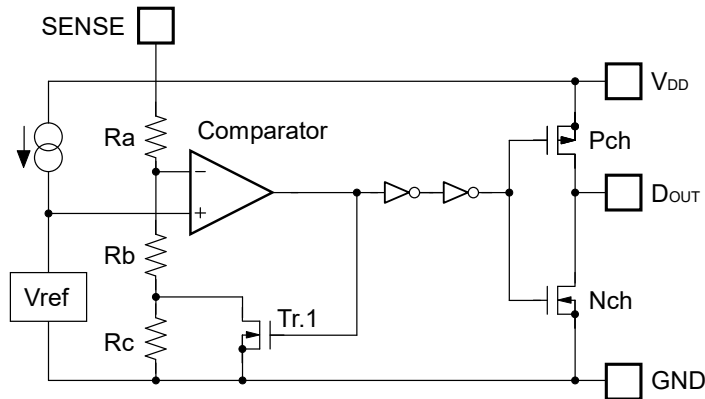

Block Diagram (R3117xxx3C)

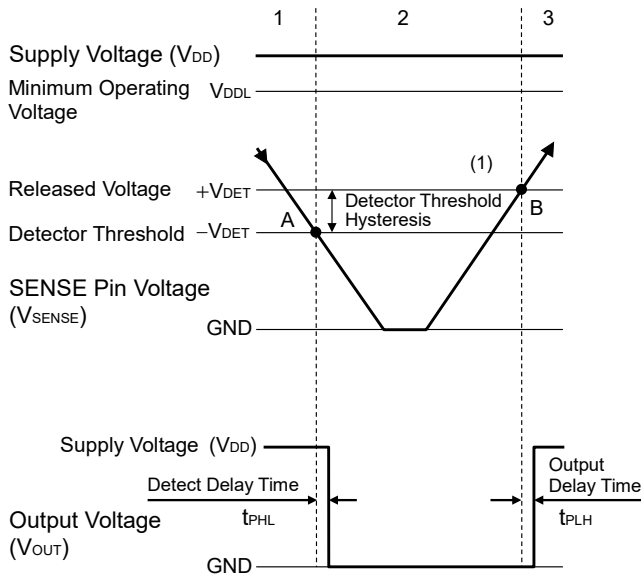

Operation Diagram

Step	1	2	3
Comparator (-) Pin Input Voltage	I	II	I
Comparator Output	L	H	L
Tr.1	OFF	ON	OFF
Output Tr.	Pch	ON	OFF
	Nch	OFF	ON

$$I \quad \frac{Rb+Rc}{Ra+Rb+Rc} \times V_{SENSE}$$

$$II \quad \frac{Rb}{Ra+Rb} \times V_{SENSE}$$

Explanation

Step 1. The output voltage is equal to the supply voltage (V_{DD}).

Step 2. At Point "A", $V_{ref} \geq V_{SENSE} \times (Rb + Rc)/(Ra + Rb + Rc)$ is true, as a result, the output of comparator is reversed from "L" to "H", therefore the output voltage becomes the GND level. The voltage level of Point A means a detector threshold voltage ($-V_{DET}$). (When the supply voltage is lower than the minimum operating voltage, the operation of the output transistor becomes indefinite. The output voltage is equal to the GND level).

Step 3. At Point "B", $V_{ref} \leq V_{SENSE} \times Rb/(Ra + Rb)$ is true, as a result, the output of comparator is reversed from "H" to "L", then the output voltage is equal to the supply voltage (V_{DD}). The voltage level of Point B means a released voltage ($+V_{DET}$).

(1) The difference between a released voltage and a detector threshold voltage is a detector threshold hysteresis.

Power Supply Injection Order

The R3117xxx3 supervises the voltage of the SENSE pin. V_{DD} pin and SENSE pin can be used at the same voltage level. Likewise, V_{DD} pin and SENSE pin can be used at the different voltage level. If the V_{DD} pin and SENSE pin are used at different voltage level, regarding the start-up sequence, force the voltage level to V_{DD} pin prior to the SENSE pin. Please note that if the V_{DD} voltage enters the shaded area in the Figure 2 after the power activation, it may cause the malfunction.

The vertical axis in the Figure 2 shows the fluctuating magnification of V_{DD} .

For example, when V_{DD} is 1.5 V with the released state and if V_{DD} increase to 5.25 V (3.5 times) within 100 ns, it may cause the malfunction.

If the SENSE pin voltage is equal or more than the released voltage ($+V_{DET}$), D_{OUT} pin becomes "H". Besides, a voltage beyond V_{DD} pin is also acceptable to SENSE pin. Concerning the R3117xxx3A (Nch open drain output type), D_{OUT} pin must be pulled-up with an external resistor.

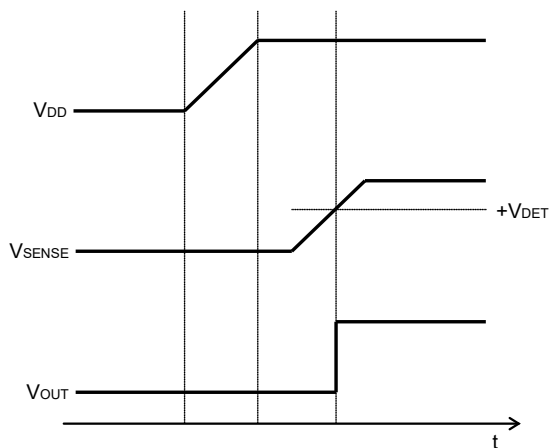

Figure 1. Turn on sequence

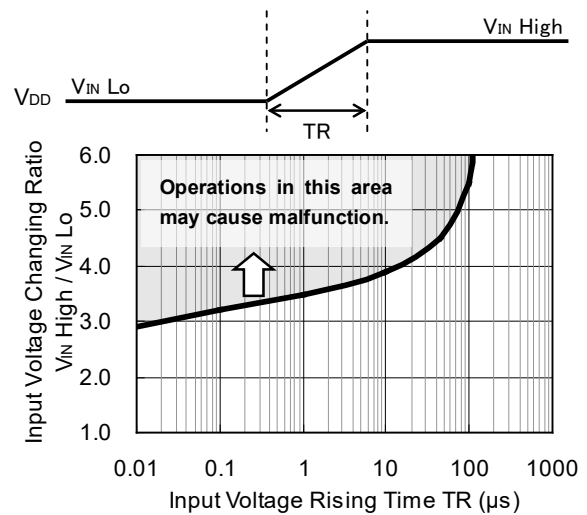

Figure 2

Outside Setting of Detector Threshold

When monitoring the voltage more than 5.0 V or the different detector threshold with using lower threshold device, divider resistors can be applied to the SENSE pin. In this usage, some error range will be generated to the detector threshold voltage caused by the internal resistor R_{SENSE} (Refer to Figure 3) of the IC. Supposed that the detector threshold voltage is described as V_s , the next equation will be true.

$$V_s = -V_{DET} \times (R_a + R_b) / R_b.$$

However, actually an error includes by SENSE resistance (R_{SENSE}) of the IC inside. (Refer to Figure 4)

$$I_a = I_b + I_{SENSE} \quad \dots\dots\dots(1)$$

$$I_b = -V_{DET} / R_b \quad \dots\dots\dots(2)$$

Thus,

$$I_a = -V_{DET} / R_b + I_{SENSE} \quad \dots\dots\dots(3)$$

Therefore,

$$V_s = -V_{DET} + I_a \times R_a \quad \dots\dots\dots(4)$$

Put Equation (3) into Equation (4), then

$$V_s = -V_{DET} \times (R_a + R_b) / R_b + R_a \times I_{SENSE}$$

$R_a \times I_{SENSE}$ is an error in V_s .

$$\begin{aligned} R_a \times I_{SENSE} &= R_a \times (-V_{DET}) / R_{SENSE} \\ &= -V_{DET} \times R_a / R_{SENSE} \end{aligned}$$

The error range is $-V_{DET} \times R_a / R_{SENSE}$ (Figure 3) and to make it small, choosing the low detector threshold voltage type and set the resistance values R_a, R_b as $R_{SENSE} \gg R_a$. Refer to the electrical characteristics table to see the R_{SENSE} value.

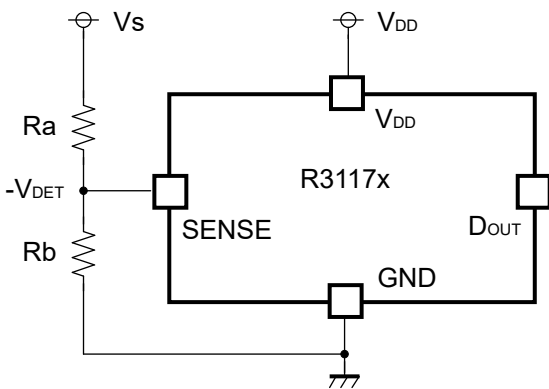

Figure 3

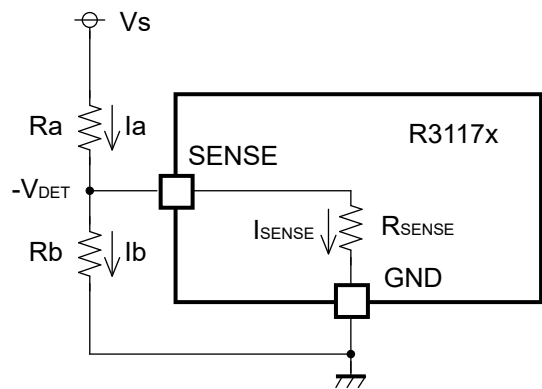

Figure 4

Accuracy Detector Threshold

If the V_{DD} bias voltage is larger than 5.25 V, and to keep the detector threshold accuracy level, or if the maximum operating voltage line must be used as the V_{DD} bias voltage, the input voltage must be set low by using the divider resistors which are shown in Figure 5.

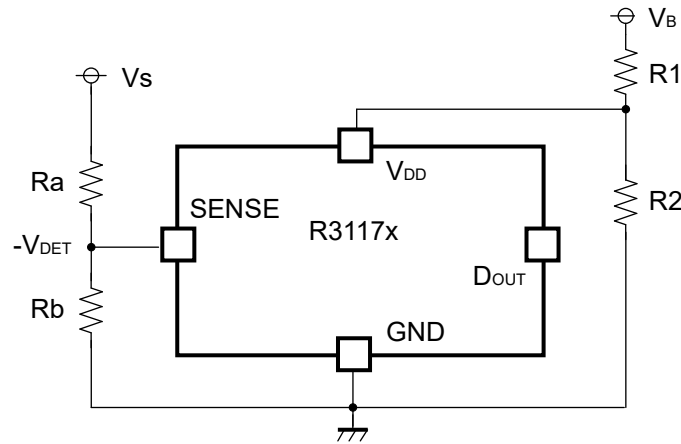
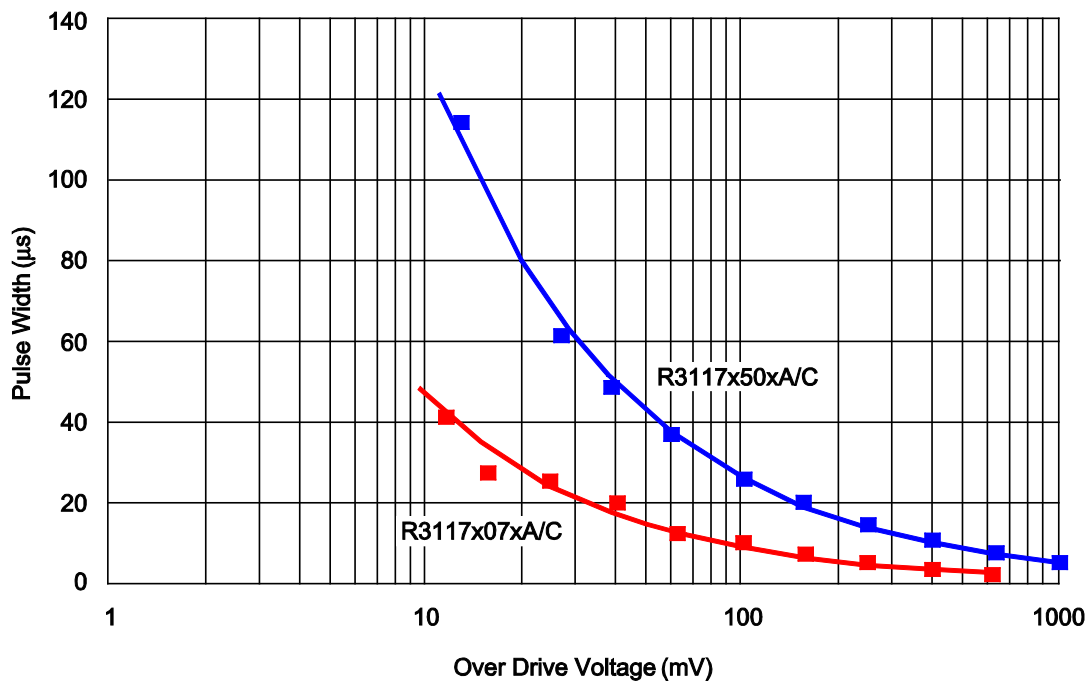
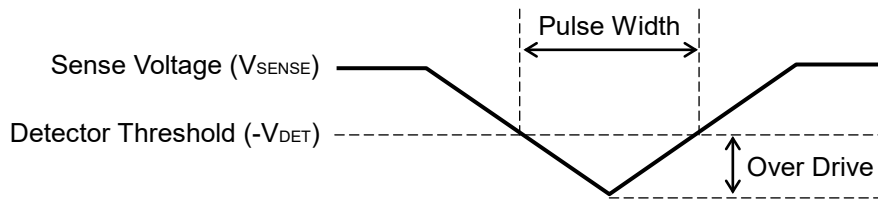

Figure 5

Detector Operation vs. glitch input voltage to the SENSE pin

When the R3117xxx3 is at released, if the pulse voltage which the detector threshold or lower voltage, the graph below means that the relation between pulse width and the amplitude of the swing to keep the released state for the R3117xxx3.





V_{SENSE} Input Waveform

This graph shows the maximum pulse conditions to keep the released voltage. If the pulse with larger amplitude or wider width than the above graph is applied to SENSE pin, the reset signal may be output.

Timing Chart

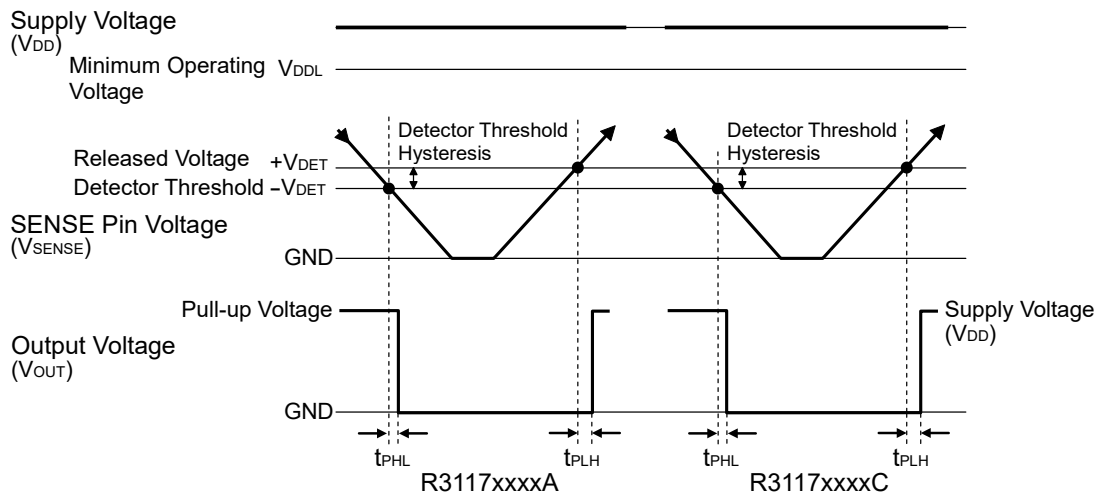

Definition of Output Delay Time

Output Delay Time (t_{PLH}) is defined as follows:

1. In the case of Nch Open Drain Output:

Under the condition of the output pin (D_{OUT}) is pulled up through a resistor of 470 k Ω to 5 V, the time interval between the rising edge of SENSE Pin pulse from 0 V to $(-V_{DET}) + 2.0$ V or the time interval of 6.0 V pulse voltage is supplied, the becoming of the output voltage to 2.5 V.

2. In the case of CMOS Output:

The time interval between the rising edge of SENSE Pin pulse from 0 V to $(-V_{DET}) + 2.0$ V or the time interval of 6.0 V pulse voltage is supplied, the becoming of the output voltage to $V_{DD}/2$.

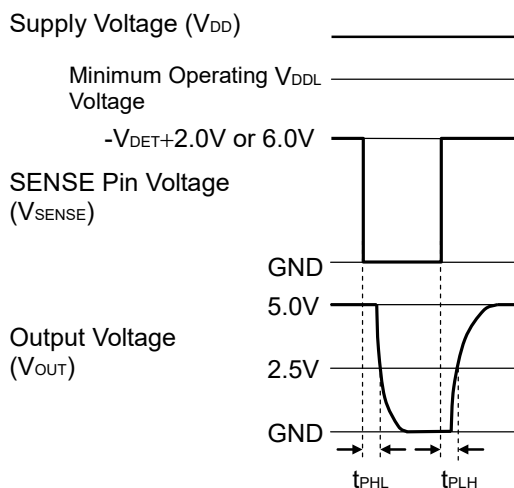

**Nch Open Drain Output
(R3117xxx3A)**

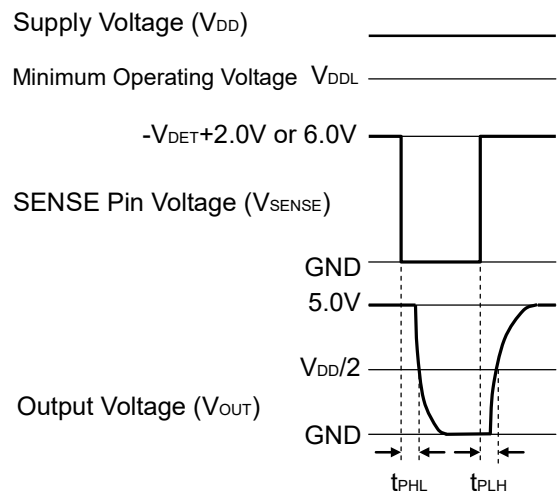

**CMOS Output
(R3117xxx3C)**

APPLICATION INFORMATION

TYPICAL APPLICATION

R3117xxx3A CPU Reset Circuit (Nch Open Drain Output)

(1) Input Voltage to R3117xxx3A is equal to Input Voltage to CPU

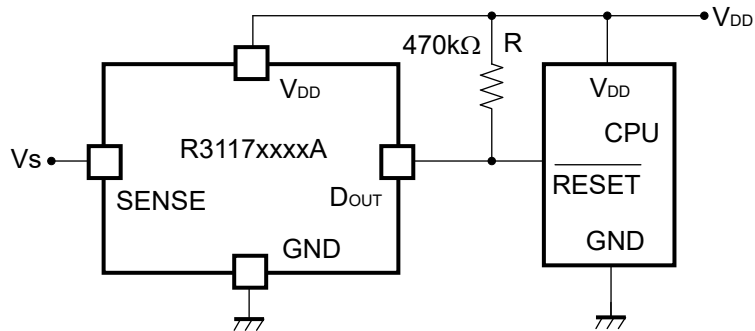

(2) Input Voltage to R3117xxx3A is unequal to Input Voltage to CPU

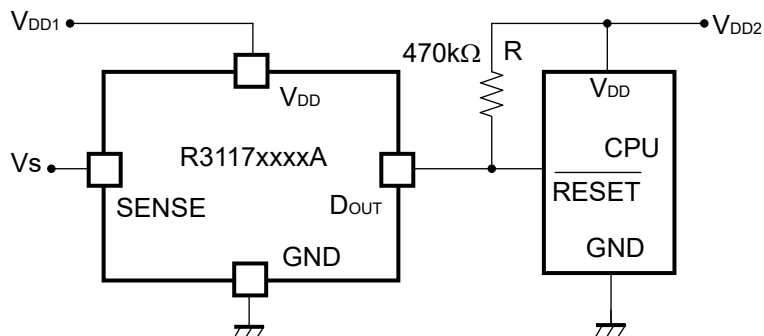

R3117xxx3C CPU Reset Circuit (CMOS Output)

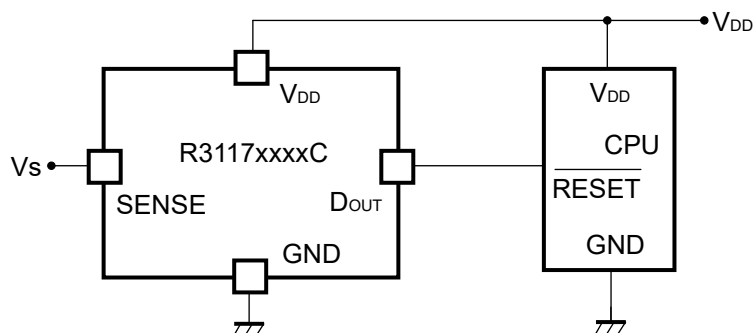

TECHNICAL NOTES

When connecting resistors to the device's input pin

When connecting a resistor (R1) to an input of this device, the input voltage decreases by [Device's Consumption Current] x [Resistance Value] only. And, the cross conduction current ⁽¹⁾, which occurs when changing from the detecting state to the release state, is decreased the input voltage by [Cross Conduction Current] x [Resistance Value] only. And then, this device will enter the re-detecting state if the input voltage reduction is larger than the difference between the detector voltage and the released voltage.

When the input resistance value is large and the V_{DD} is gone up at mildly in the vicinity of the released voltage, repeating the above operation may result in the occurrence of output.

As shown in Figure A/B, set R1 to become 100 k Ω or less as a guide, and connect C_{IN} of 0.1 μ F and more to between the input pin and GND. Besides, make evaluations including temperature properties under the actual usage condition, with using the evaluation board like this way. As result, make sure that the cross conduction current has no problem.

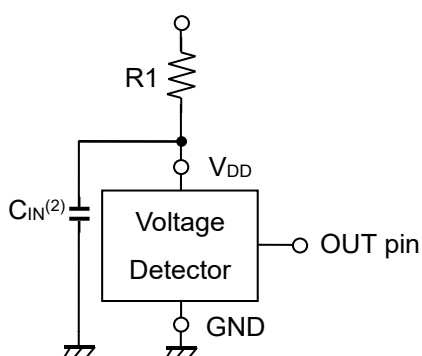

Figure A

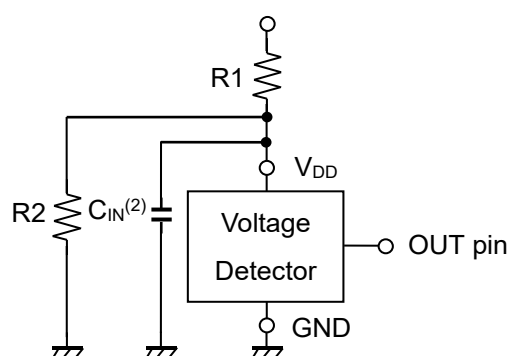

Figure B

⁽¹⁾ In the CMOS output type, a charging current for OUT pin is included.

⁽²⁾ Note the bias dependence of capacitors.

TYPICAL PERFORMANCE CHARACTERISTICS

Typical performance characteristics are intended to be used as reference data, they are not guaranteed.

1) Supply Current vs. Supply Voltage

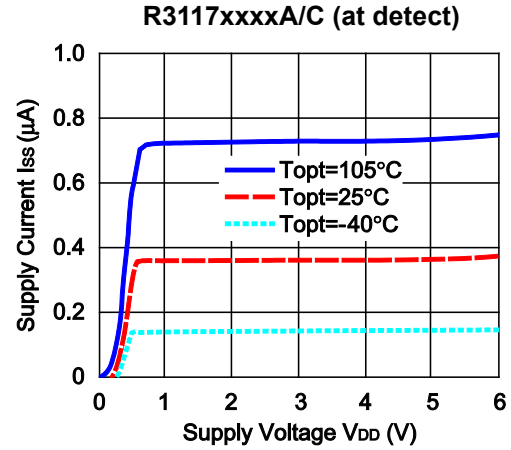
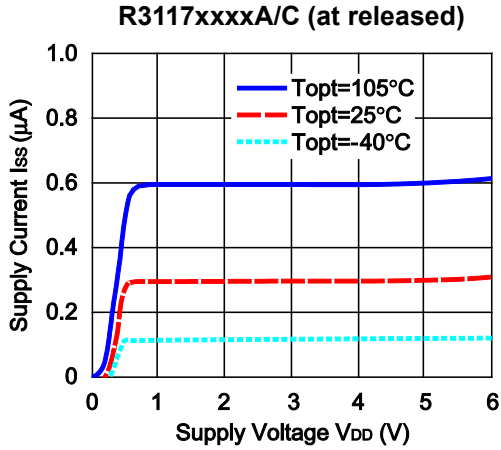

2) Detector Threshold vs. Temperature

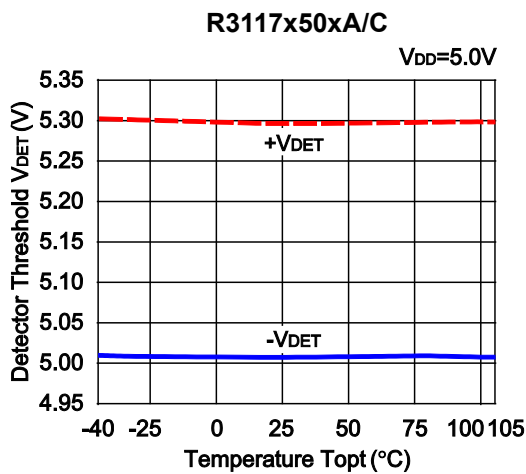
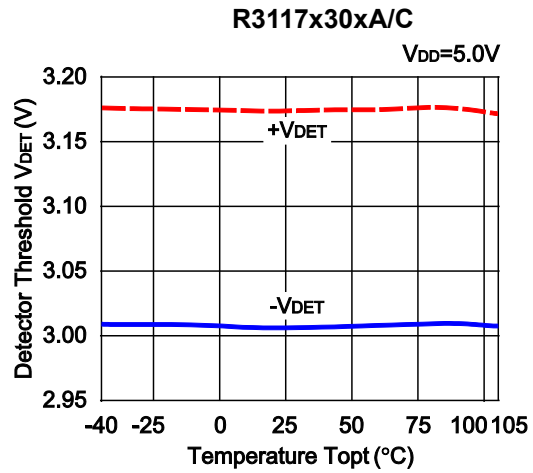
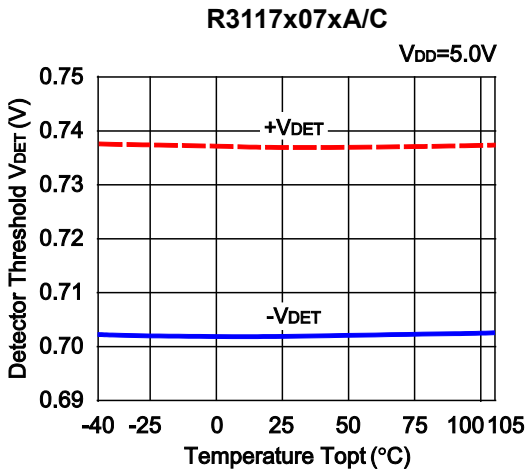

3) Detector Threshold vs. Supply Voltage

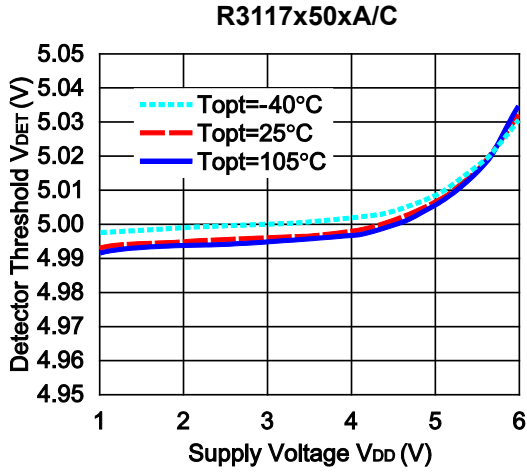
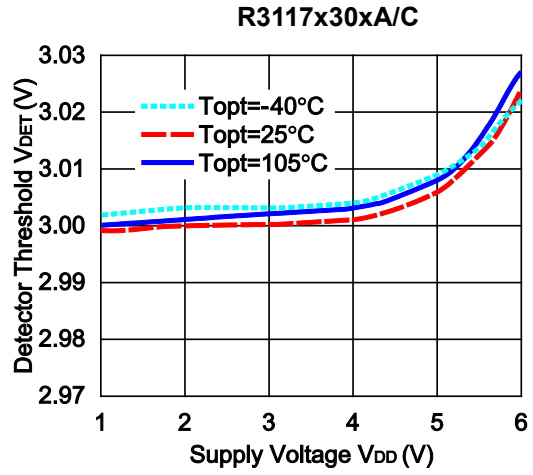
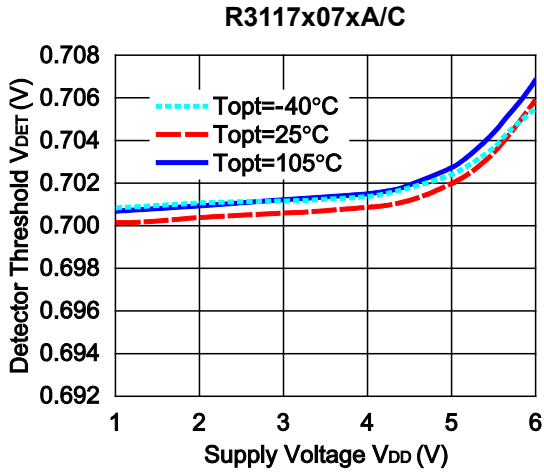

4) Hysteresis vs. Supply Voltage

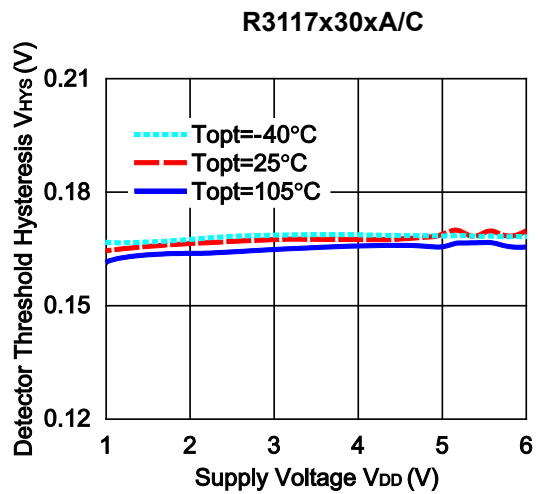
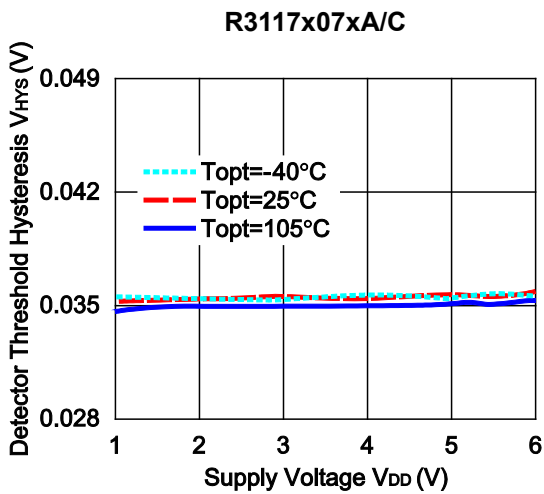

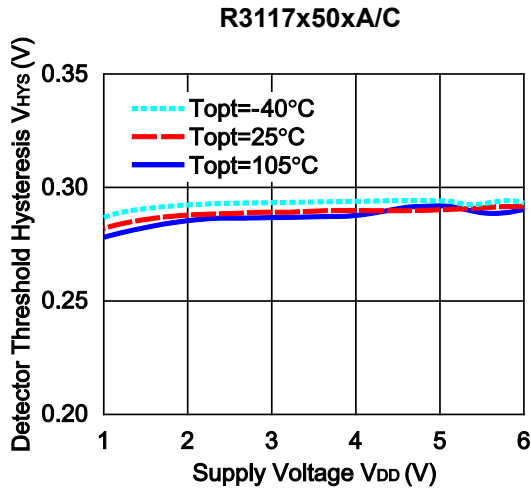

5) Output Voltage vs. SENSE pin Input Voltage (Nch Open Drain Output type is pulled up to V_{DD})

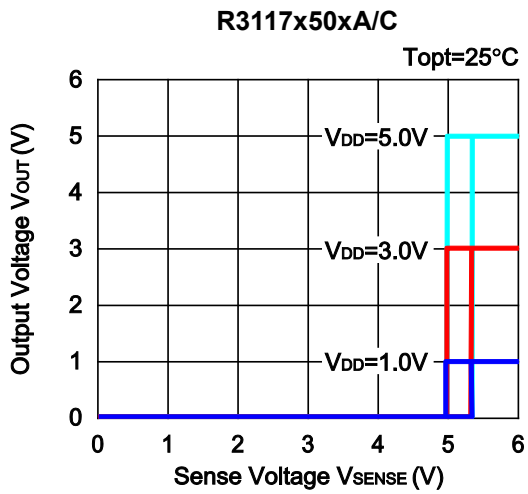
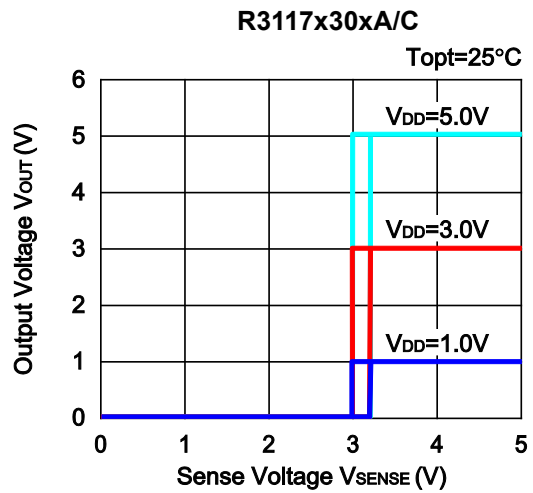
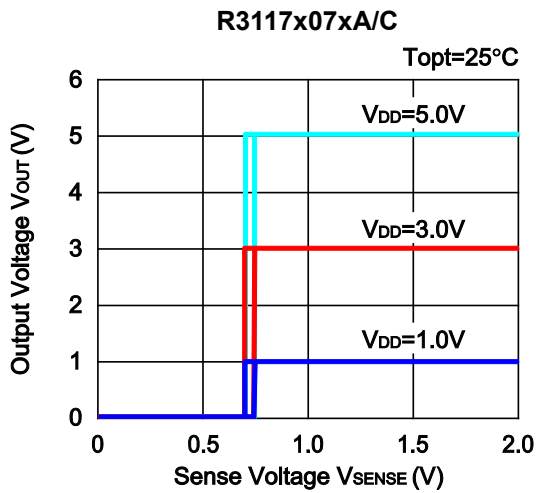

6) Nch Driver Output Current vs. Supply Voltage

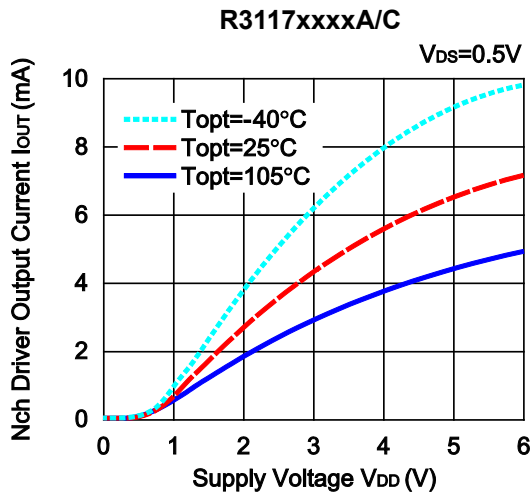

7) Nch Driver Output Current vs. V_{DS}

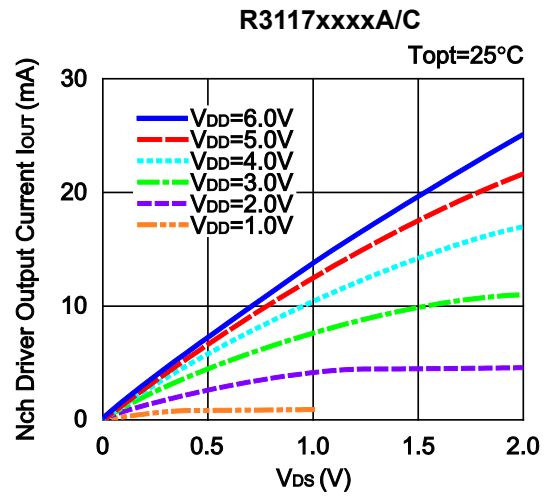

8) Pch Driver Output Current vs. Supply Voltage

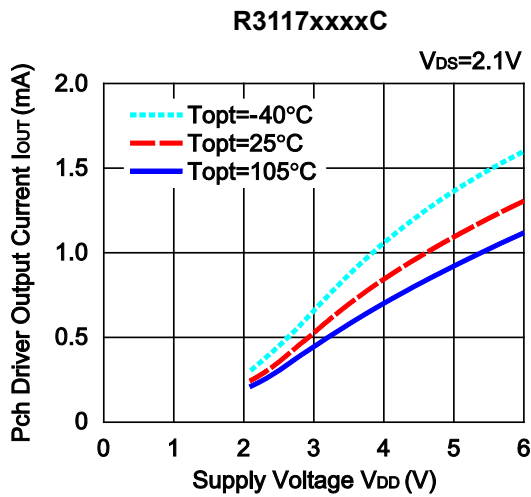

9) Pch Driver Output Current vs. V_{DS}

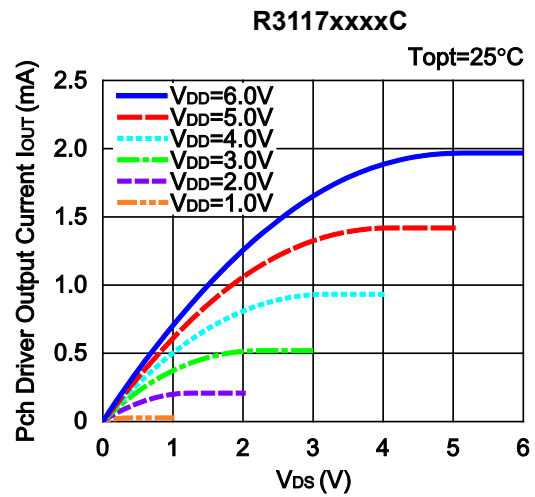

The power dissipation of the package is dependent on PCB material, layout, and environmental conditions. The following measurement conditions are based on JEDEC STD. 51.

Measurement Conditions

Item	Measurement Conditions
Environment	Mounting on Board (Wind Velocity = 0 m/s)
Board Material	Glass Cloth Epoxy Plastic (Four-Layer Board)
Board Dimensions	76.2 mm × 114.3 mm × 0.8 mm
Copper Ratio	Outer Layer (First Layer): Less than 95% of 50 mm Square Inner Layers (Second and Third Layers): Approx. 100% of 50 mm Square Outer Layer (Fourth Layer): Approx. 100% of 50 mm Square
Through-holes	φ 0.2 mm × 21 pcs

Measurement Result

(Ta = 25°C, Tjmax = 125°C)

Item	Measurement Result
Power Dissipation	800 mW
Thermal Resistance (θja)	θja = 125°C/W
Thermal Characterization Parameter (ψjt)	ψjt = 58°C/W

θja: Junction-to-Ambient Thermal Resistance

ψjt: Junction-to-Top Thermal Characterization Parameter

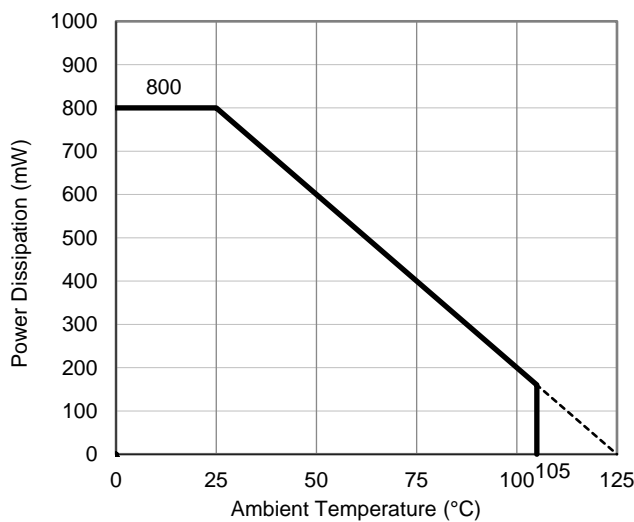

Power Dissipation vs. Ambient Temperature

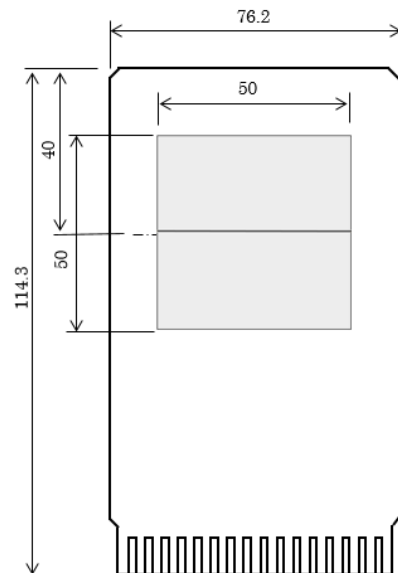

Measurement Board Pattern

The power dissipation of the package is dependent on PCB material, layout, and environmental conditions. The following measurement conditions are based on JEDEC STD. 51-7.

Measurement Conditions

Item	Measurement Conditions
Environment	Mounting on Board (Wind Velocity = 0 m/s)
Board Material	Glass Cloth Epoxy Plastic (Four-Layer Board)
Board Dimensions	76.2 mm × 114.3 mm × 0.8 mm
Copper Ratio	Outer Layer (First Layer): Less than 95% of 50 mm Square Inner Layers (Second and Third Layers): Approx. 100% of 50 mm Square Outer Layer (Fourth Layer): Approx. 100% of 50 mm Square
Through-holes	φ 0.3 mm × 7 pcs

Measurement Result

(Ta = 25°C, Tjmax = 125°C)

Item	Measurement Result
Power Dissipation	660 mW
Thermal Resistance (θja)	θja = 150°C/W
Thermal Characterization Parameter (ψjt)	ψjt = 51°C/W

θja: Junction-to-Ambient Thermal Resistance

ψjt: Junction-to-Top Thermal Characterization Parameter

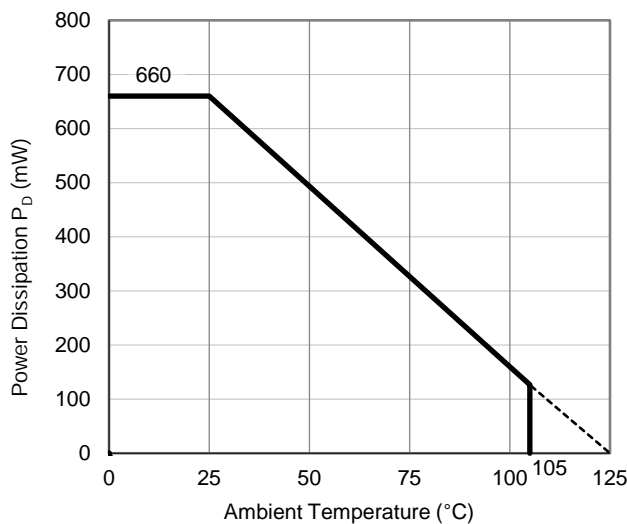

Power Dissipation vs. Ambient Temperature

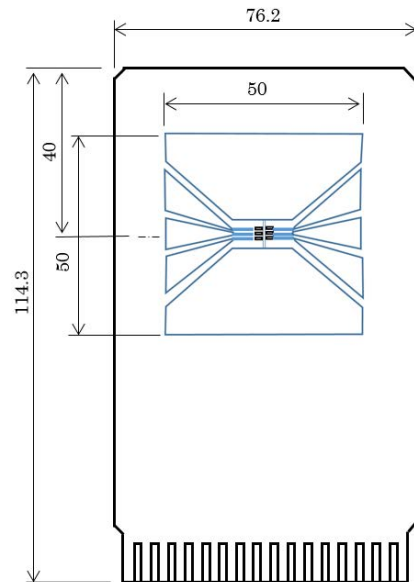

Measurement Board Pattern

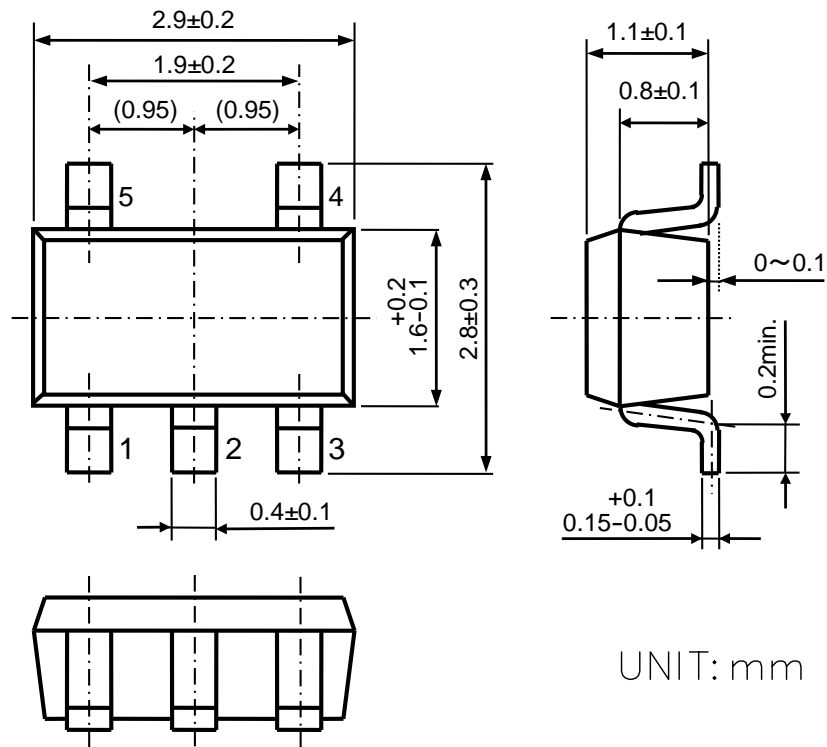

SOT-23-5 Package Dimensions

1. The products and the product specifications described in this document are subject to change or discontinuation of production without notice for reasons such as improvement. Therefore, before deciding to use the products, please refer to our sales representatives for the latest information thereon.
2. The materials in this document may not be copied or otherwise reproduced in whole or in part without the prior written consent of us.
3. This product and any technical information relating thereto are subject to complementary export controls (so-called KNOW controls) under the Foreign Exchange and Foreign Trade Law, and related politics ministerial ordinance of the law. (Note that the complementary export controls are inapplicable to any application-specific products, except rockets and pilotless aircraft, that are insusceptible to design or program changes.) Accordingly, when exporting or carrying abroad this product, follow the Foreign Exchange and Foreign Trade Control Law and its related regulations with respect to the complementary export controls.
4. The technical information described in this document shows typical characteristics and example application circuits for the products. The release of such information is not to be construed as a warranty of or a grant of license under our or any third party's intellectual property rights or any other rights.
5. The products listed in this document are intended and designed for use as general electronic components in standard applications (office equipment, telecommunication equipment, measuring instruments, consumer electronic products, amusement equipment etc.). Those customers intending to use a product in an application requiring extreme quality and reliability, for example, in a highly specific application where the failure or misoperation of the product could result in human injury or death should first contact us.
 - Aerospace Equipment
 - Equipment Used in the Deep Sea
 - Power Generator Control Equipment (nuclear, steam, hydraulic, etc.)
 - Life Maintenance Medical Equipment
 - Fire Alarms / Intruder Detectors
 - Vehicle Control Equipment (automotive, airplane, railroad, ship, etc.)
 - Various Safety Devices
 - Traffic control system
 - Combustion equipment

In case your company desires to use this product for any applications other than general electronic equipment mentioned above, make sure to contact our company in advance. Note that the important requirements mentioned in this section are not applicable to cases where operation requirements such as application conditions are confirmed by our company in writing after consultation with your company.

6. We are making our continuous effort to improve the quality and reliability of our products, but semiconductor products are likely to fail with certain probability. In order to prevent any injury to persons or damages to property resulting from such failure, customers should be careful enough to incorporate safety measures in their design, such as redundancy feature, fire containment feature and fail-safe feature. We do not assume any liability or responsibility for any loss or damage arising from misuse or inappropriate use of the products.
7. The products have been designed and tested to function within controlled environmental conditions. Do not use products under conditions that deviate from methods or applications specified in this datasheet. Failure to employ the products in the proper applications can lead to deterioration, destruction or failure of the products. We shall not be responsible for any bodily injury, fires or accident, property damage or any consequential damages resulting from misuse or misapplication of the products.
8. **Quality Warranty**
 - 8-1. **Quality Warranty Period**

In the case of a product purchased through an authorized distributor or directly from us, the warranty period for this product shall be one (1) year after delivery to your company. For defective products that occurred during this period, we will take the quality warranty measures described in section 8-2. However, if there is an agreement on the warranty period in the basic transaction agreement, quality assurance agreement, delivery specifications, etc., it shall be followed.
 - 8-2. **Quality Warranty Remedies**

When it has been proved defective due to manufacturing factors as a result of defect analysis by us, we will either deliver a substitute for the defective product or refund the purchase price of the defective product.

Note that such delivery or refund is sole and exclusive remedies to your company for the defective product.
 - 8-3. **Remedies after Quality Warranty Period**

With respect to any defect of this product found after the quality warranty period, the defect will be analyzed by us. On the basis of the defect analysis results, the scope and amounts of damage shall be determined by mutual agreement of both parties. Then we will deal with upper limit in Section 8-2. This provision is not intended to limit any legal rights of your company.
9. Anti-radiation design is not implemented in the products described in this document.
10. The X-ray exposure can influence functions and characteristics of the products. Confirm the product functions and characteristics in the evaluation stage.
11. WLCSP products should be used in light shielded environments. The light exposure can influence functions and characteristics of the products under operation or storage.
12. Warning for handling Gallium and Arsenic (GaAs) products (Applying to GaAs MMIC, Photo Reflector). These products use Gallium (Ga) and Arsenic (As) which are specified as poisonous chemicals by law. For the prevention of a hazard, do not burn, destroy, or process chemically to make them as gas or power. When the product is disposed of, please follow the related regulation and do not mix this with general industrial waste or household waste.
13. Please contact our sales representatives should you have any questions or comments concerning the products or the technical information.



Nisshinbo Micro Devices Inc.

Official website

<https://www.nisshinbo-microdevices.co.jp/en/>

Purchase information

<https://www.nisshinbo-microdevices.co.jp/en/buy/>