

# Improved Current Mode PWM Controller

## FEATURES

- Pin-for-Pin Compatible With the UC3846
- 65ns Typical Delay From Shutdown to Outputs, and 50ns Typical Delay From Sync to Outputs
- Improved Current Sense Amplifier With Reduced Noise Sensitivity
- Differential Current Sense with 3V Common Mode Range
- Trimmed Oscillator Discharge Current for Accurate Deadband Control
- Accurate 1V Shutdown Threshold
- High Current Dual Totem Pole Outputs (1.5A peak)
- TTL Compatible Oscillator SYNC Pin Thresholds
- 4kV ESD Protection

## DESCRIPTION

The UC3856 is a high performance version of the popular UC3846 series of current mode controllers, and is intended for both design upgrades and new applications where speed and accuracy are important. All input to output delays have been minimized, and the current sense output is slew rate limited to reduce noise sensitivity. Fast 1.5A peak output stages have been added to allow rapid switching of power FETs.

A low impedance TTL compatible sync output has been implemented with a tri-state function when used as a sync input.

Internal chip grounding has been improved to minimize internal "noise" caused when driving large capacitive loads. This, in conjunction with the improved differential current sense amplifier results in enhanced noise immunity.

Other features include a trimmed oscillator current (8%) for accurate frequency and dead time control; a 1V, 5% shutdown threshold; and 4kV minimum ESD protection on all pins.

## BLOCK DIAGRAM

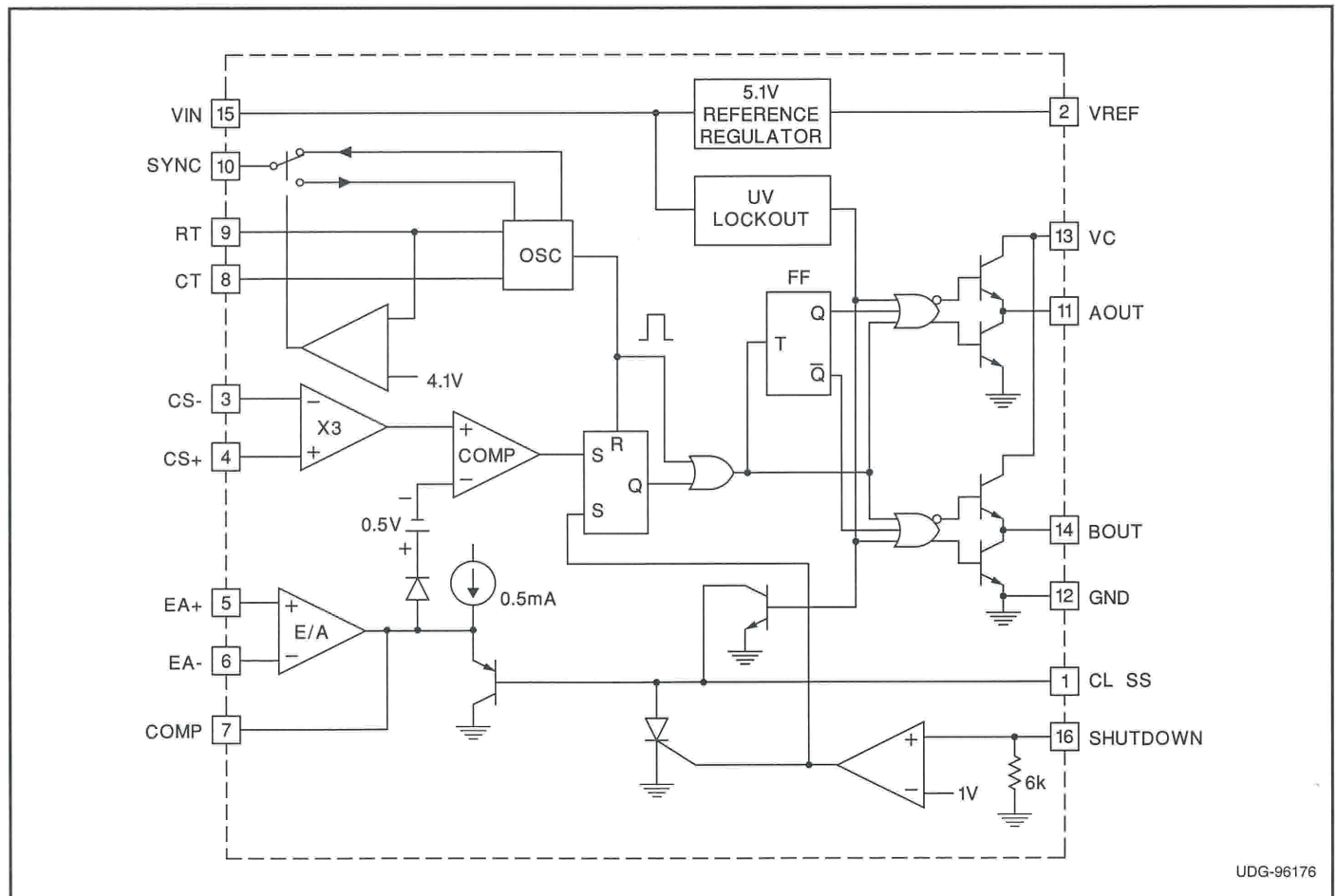

UDG-96176

**ABSOLUTE MAXIMUM RATINGS**

Supply Voltage	+40V
Collector Supply Voltage	+40V
Output Current, Source or Sink	
DC	0.5A
Pulse (0.5μs)	2.0A
Error Amp Inputs	-0.3V to +V <sub>IN</sub>
Shutdown Input	-0.3V to +10V
Current Sense Inputs	-0.3V to +3V
SYNC Output Current	±10mA
Error Amplifier Output Current	-5mA
Soft Start Sink Current	50mA
Oscillator Charging Current	5mA
Power Dissipation at T <sub>A</sub> = 25°C (Note 2)	1000mW
Power Dissipation at T <sub>C</sub> = 25°C (Note 2)	2000mW
Junction Temperature	-55°C to +150°C
Storage Temperature Range	-65°C to +150°C
Lead Temperature (Soldering, 10 sec.)	+300°C

*All voltages are with respect to Ground. Currents are positive into, negative out of the specified terminal. Consult packaging section of databook for thermal limitations and considerations of package.*

**CONNECTION DIAGRAMS**

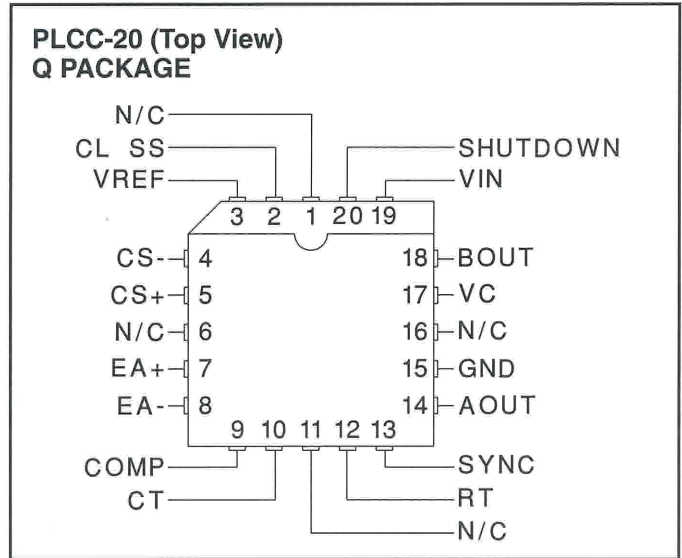
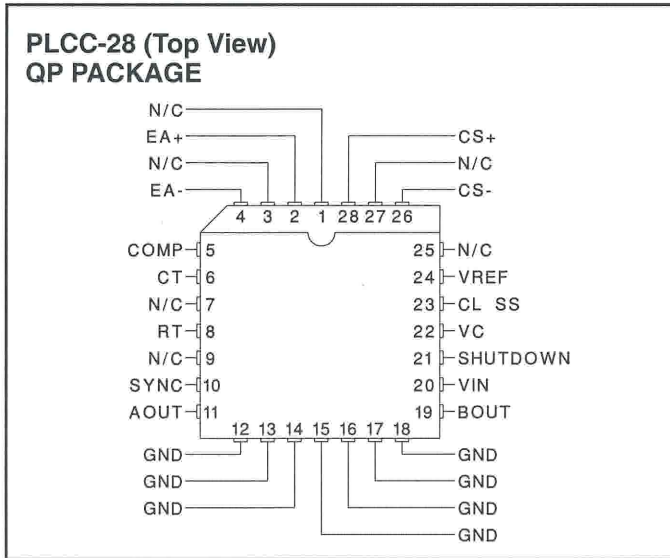
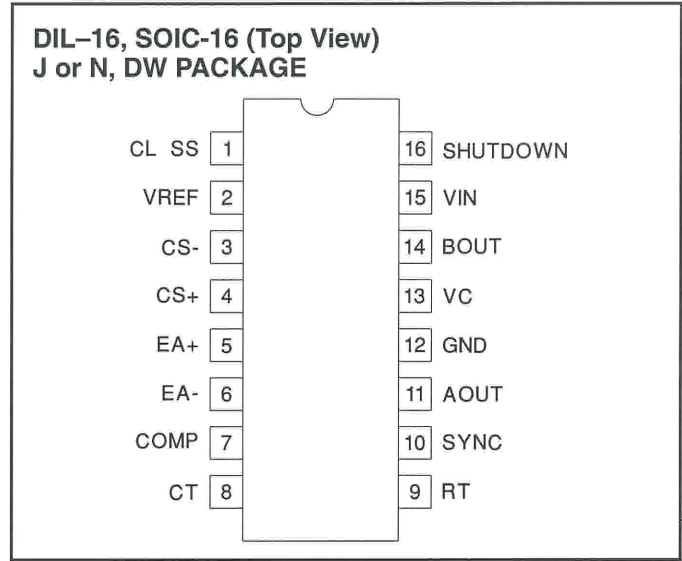

**ELECTRICAL CHARACTERISTICS:** Unless otherwise stated, these specifications apply for T<sub>A</sub> = -55°C to +125°C for UC1856; -40°C to +85°C for the UC2856; and 0°C to +70°C for the UC3856, V<sub>IN</sub> = 15V, R<sub>T</sub> = 10k, C<sub>T</sub> = 1nF, T<sub>A</sub> = T<sub>J</sub>.

PARAMETER	TEST CONDITIONS	UC1856/UC2856			UC3856			UNITS
		MIN	TYP	MAX	MIN	TYP	MAX	
<b>Reference Section</b>								
Output Voltage	T <sub>J</sub> = 25°C, I <sub>O</sub> = 1mA	5.05	5.10	5.15	5.00	5.10	5.20	V
Line Regulation	V <sub>IN</sub> = 8V to 40V			20			20	mV
Load Regulation	I <sub>O</sub> = -1mA to -10mA			15			15	mV
Total Output Variation	Line, Load, and Temperature	5.00		5.20	4.95		5.25	V
Output Noise Voltage	10Hz < f < 10kHz, T <sub>J</sub> = 25°C		50			50		μV
Long Term Stability	T <sub>J</sub> = 125°C, 1000 Hrs (Note 2)		5	25		5	25	mV
Short Circuit Current	VREF = 0V	-25	-45	-65	-25	-45	-65	mA
<b>Oscillator Section</b>								
Initial Accuracy	T <sub>J</sub> = 25°C	180	200	220	180	200	220	kHz
	Over Operating Range	170		230	170		230	kHz

**ELECTRICAL CHARACTERISTICS:** Unless otherwise stated, these specifications apply for  $T_A = -55^\circ\text{C}$  to  $+125^\circ\text{C}$  for UC1856;  $-40^\circ\text{C}$  to  $+85^\circ\text{C}$  for the UC2856; and  $0^\circ\text{C}$  to  $+70^\circ\text{C}$  for the UC3856,  $V_{IN} = 15\text{V}$ ,  $R_T = 10\text{k}$ ,  $C_T = 1\text{nF}$ ,  $T_A = T_J$ .

PARAMETER	TEST CONDITIONS	UC1856/UC2856			UC3856			UNITS
		MIN	TYP	MAX	MIN	TYP	MAX	
<b>Oscillator Section (cont.)</b>								
Voltage Stability	$V_{IN} = 8\text{V}$ to $40\text{V}$			2			2	%
Discharge Current	$T_J = 25^\circ\text{C}$ , $V_{CT} = 2\text{V}$	7.5	8.0	8.8	7.5	8.0	8.8	mA
	$V_{CT} = 2\text{V}$	6.7	8.0	8.8	6.7	8.0	8.8	mA
Sync Output High Level	$I_O = -1\text{mA}$	2.4	3.6		2.4	3.6		V
Sync Output Low Level	$I_O = +1\text{mA}$		0.2	0.4		0.2	0.4	V
Sync Input High Level	$C_T = 0\text{V}$ , $R_T = V_{REF}$	2.0	1.5		2.0	1.5		V
Sync Input Low Level	$C_T = 0\text{V}$ , $R_T = V_{REF}$		1.5	0.8		1.5	0.8	V
Sync Input Current	$C_T = 0\text{V}$ , $R_T = V_{REF}$ $V_{SYNC} = 5\text{V}$		1	10		1	10	$\mu\text{A}$
Sync Delay to Outputs	$C_T = 0\text{V}$ , $R_T = V_{REF}$ $V_{SYNC} = 0.8\text{V}$ to $2\text{V}$		50	100		50	100	ns
<b>Error Amplifier Section</b>								
Input Offset Voltage	$V_{CM} = 2\text{V}$			5			10	mV
Input Bias Current				-1			-1	$\mu\text{A}$
Input Offset Current				500			500	nA
Common Mode Range	$V_{IN} = 8\text{V}$ to $40\text{V}$	0		$V_{IN}-2$	0		$V_{IN}-2$	V
Open Loop Gain	$V_O = 1.2\text{V}$ to $3\text{V}$	80	100		80	100		dB
Unity Gain Bandwidth	$T_J = 25^\circ\text{C}$	1	1.5		1	1.5		MHz
CMRR	$V_{CM} = 0\text{V}$ to $38\text{V}$ , $V_{IN} = 40\text{V}$	75	100		75	100		dB
PSRR	$V_{IN} = 8\text{V}$ to $40\text{V}$	80	100		80	100		dB
Output Sink Current	$V_{ID} = -15\text{mV}$ , $V_{COMP} = 1.2\text{V}$	5	10		5	10		mA
Output Source Current	$V_{ID} = 15\text{mV}$ , $V_{COMP} = 2.5\text{V}$	-0.4	-0.5		-0.4	-0.5		mA
Output High Level	$V_{ID} = 50\text{mV}$ , $R_L$ (COMP) = $15\text{k}$	4.3	4.6	4.9	4.3	4.6	4.9	V
Output Low Level	$V_{ID} = -50\text{mV}$ , $R_L$ (COMP) = $15\text{k}$		0.7	1		0.7	1	V
<b>Current Sense Amplifier Section</b>								
Amplifier Gain	$V_{CS-} = 0\text{V}$ , CL SS Open (Notes 3,4)	2.5	2.75	3.0	2.5	2.75	3.0	V/V
Maximum Differential Input Signal ( $V_{CS+} - V_{CS-}$ )	CL SS Open (Note 3) $R_L$ (COMP) = $15\text{k}$	1.1	1.2		1.1	1.2		V
Input Offset Voltage	$V_{CL SS} = 0.5\text{V}$ COMP Open (Note 3)		5	35		5	35	mV
CMRR	$V_{CM} = 0\text{V}$ to $3\text{V}$	60			60			dB
PSRR	$V_{IN} = 8\text{V}$ to $40\text{V}$	60			60			dB
Input Bias Current	$V_{CL SS} = 0.5\text{V}$ , COMP Open (Note 3)	-1		1	-1		1	$\mu\text{A}$
Input Offset Current	$V_{CL SS} = 0.5\text{V}$ , COMP Open (Note 3)	-1		1	-1		1	$\mu\text{A}$
Input Common Mode Range		0		3	0		3	V
Delay to Outputs	$V_{EA+} = V_{REF}$ , $EA- = 0\text{V}$ $CS+ - CS- = 0\text{V}$ to $1.5\text{V}$		120	250		120	250	ns
<b>Current Limit Adjust Section</b>								
Current Limit Offset	$V_{CS-} = 0\text{V}$ $V_{CS+} = 0\text{V}$ , COMP = Open (Note 3)	0.43	0.5	0.57	0.43	0.5	0.57	V
Input Bias Current	$V_{EA+} = V_{REF}$ , $V_{EA-} = 0\text{V}$		-10	-30		-10	-30	$\mu\text{A}$
<b>Shutdown Terminal Section</b>								
Threshold Voltage		0.95	1.00	1.05	0.95	1.00	1.05	V
Input Voltage Range		0		5	0		5	V

**ELECTRICAL CHARACTERISTICS:** Unless otherwise stated, these specifications apply for  $T_A = -55^\circ\text{C}$  to  $+125^\circ\text{C}$  for UC1856;  $-40^\circ\text{C}$  to  $+85^\circ\text{C}$  for the UC2856; and  $0^\circ\text{C}$  to  $+70^\circ\text{C}$  for the UC3856,  $V_{IN} = 15\text{V}$ ,  $R_T = 10\text{k}$ ,  $C_T = 1\text{nF}$ ,  $T_A = T_J$ .

PARAMETER	TEST CONDITIONS	UC1856/UC2856			UC3856			UNITS
		MIN	TYP	MAX	MIN	TYP	MAX	
<b>Shutdown Terminal Section (cont.)</b>								
Minimum Latching Current ( $I_{CL\ SS}$ )	(Note 5)	3	1.5		3	1.5		mA
Maximum Non-Latching Current ( $I_{CL\ SS}$ )	(Note 6)		1.5	0.8		1.5	0.8	mA
Delay to Outputs	$V_{SHUTDOWN} = 0$ to $1.3\text{V}$		65	110		65	110	ns
<b>Output Section</b>								
Collector-Emitter Voltage		40			40			V
Off-State Bias Current	$V_C = 40\text{V}$			250			250	$\mu\text{A}$
Output Low Level	$I_{OUT} = 20\text{mA}$		0.1	0.5		0.1	0.5	V
	$I_{OUT} = 200\text{mA}$		0.5	2.6		0.5	2.6	V
Output High Level	$I_{OUT} = -20\text{mA}$	12.5	13.2		12.5	13.2		V
	$I_{OUT} = -200\text{mA}$	12	13.1		12	13.1		V
Rise Time	$C_1 = 1\text{nF}$		40	80		40	80	ns
Fall Time	$C_1 = 1\text{nF}$		40	80		40	80	ns
UVLO Low Saturation	$V_{IN} = 0\text{V}$ , $I_{OUT} = 20\text{mA}$		0.8	1.5		0.8	1.5	V
<b>PWM Section</b>								
Maximum Duty Cycle		45	47	50	45	47	50	%
Minimum Duty Cycle				0			0	%
<b>Undervoltage Lockout Section</b>								
Startup Threshold			7.7	8.0		7.7	8.0	V
Threshold Hysteresis			0.7			0.7		V
<b>Total Standby Current</b>								
Supply Current			18	23		18	23	mA

Note 1: All voltages are with respect to GND. Currents are positive into, negative out of the specified terminal.

Note 2: This parameter, although guaranteed over the recommended operating conditions is not 100% tested in production.

Note 3: Parameter measured at trip point of latch with  $V_{EA+} = V_{REF}$ ,  $V_{EA-} = 0\text{V}$ .

Note 4: Amplifier gain defined as:

$$G = \frac{\Delta V_{COMP}}{\Delta V_{CS+}}; \quad \Delta V_{CS-} = 0\text{V TO } 1.0\text{V}$$

Note 5: Current into CL SS guaranteed to latch circuit into shutdown state.

Note 6: Current into CL SS guaranteed not to latch circuit into shutdown state.

APPLICATIONS INFORMATION

### Oscillator Circuit

Output deadtime is determined by size of the external capacitor,  $C_T$ , according to the formula:  $T_d = \frac{2C_T}{8mA - \frac{3.6}{R_T}}$

For large values of  $R_T$ :  $T_d = 250C_T$

Oscillator frequency is approximated by the formula:  $f_T = \frac{2}{R_T C_T}$

UDG-96177

### Error Amplifier Output Configuration

UDG-96178

$I_i < 0.5mA$

Error Amplifier can source up to 0.5mA.

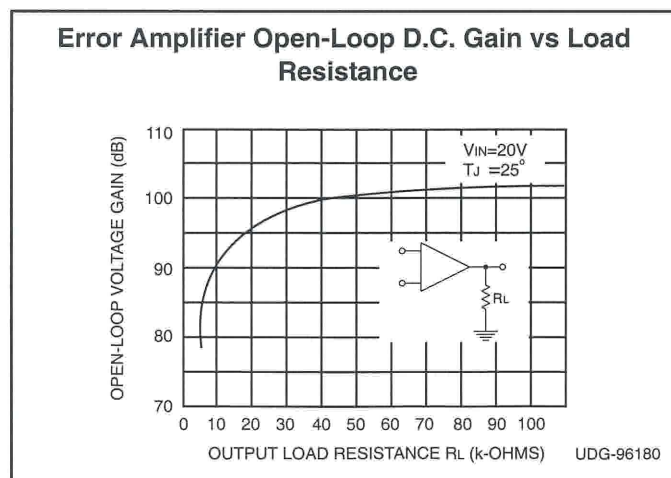
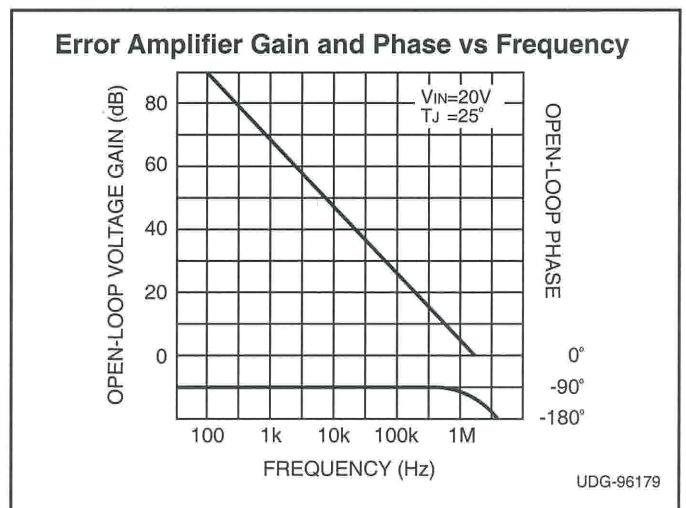

APPLICATIONS INFORMATION (cont.)

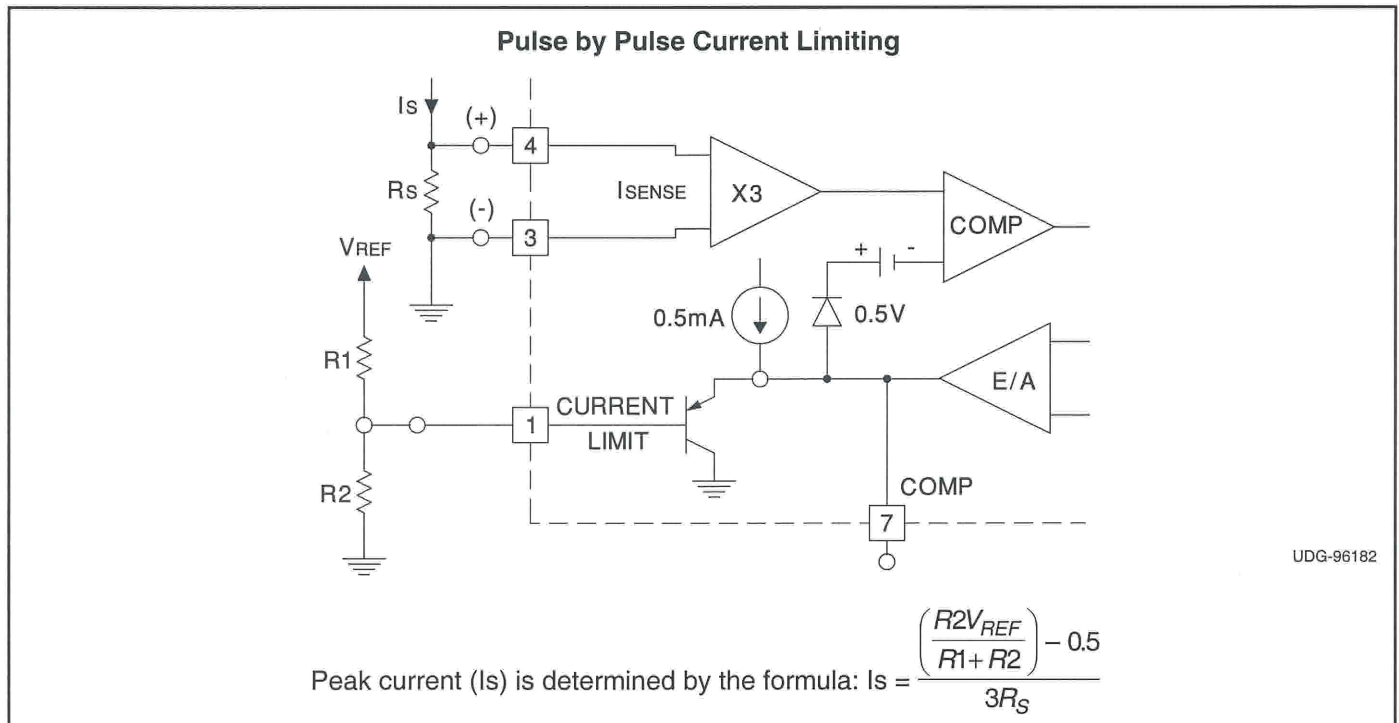
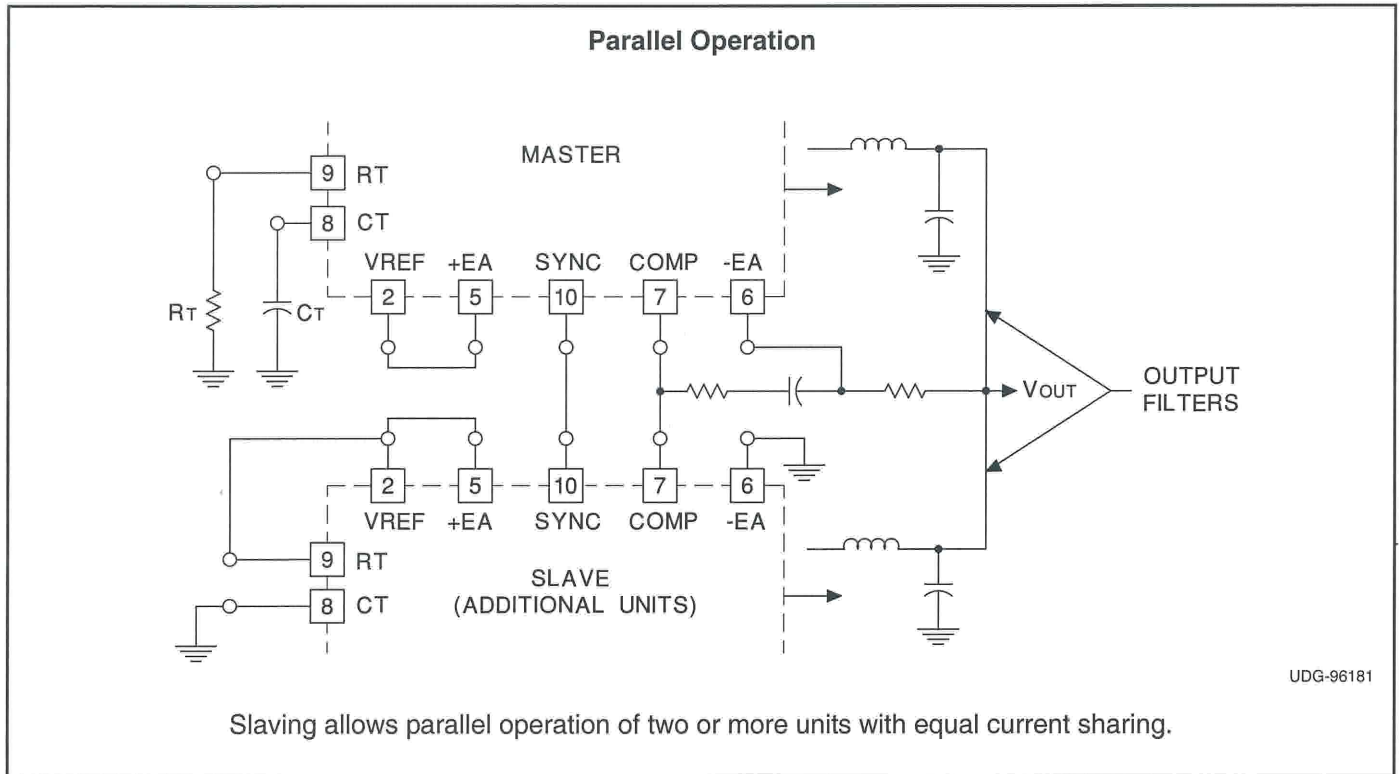

APPLICATIONS INFORMATION (cont.)

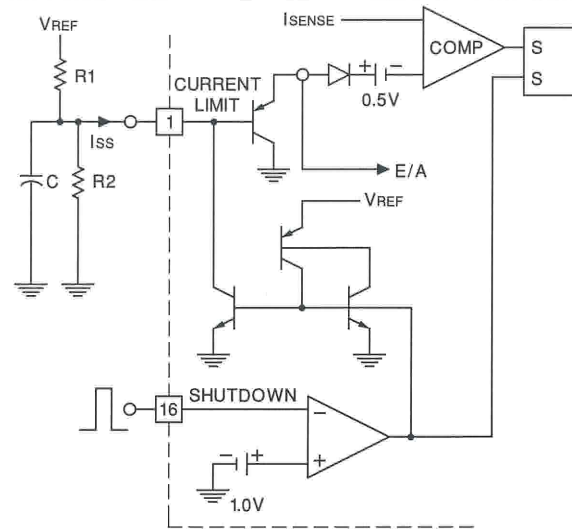

UDG-96183

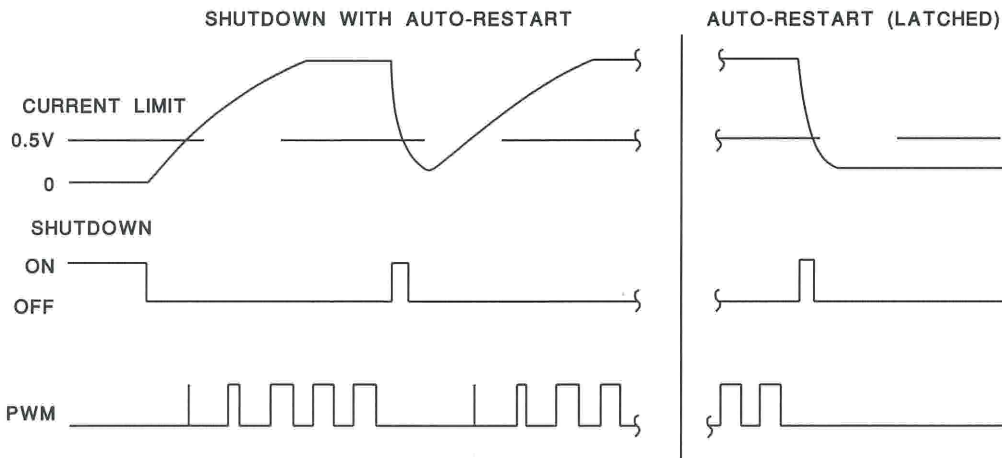

UDG-96184

If  $\frac{V_{REF}}{R1} < 0.8\text{mA}$ , the shutdown latch will commutate when  $I_{ss} = 0.8\text{mA}$  and a restart cycle will be initiated.

If  $\frac{V_{REF}}{R1} > 3\text{mA}$ , the device will latch off until power is recycled.

Current Sense Amplifier Connections

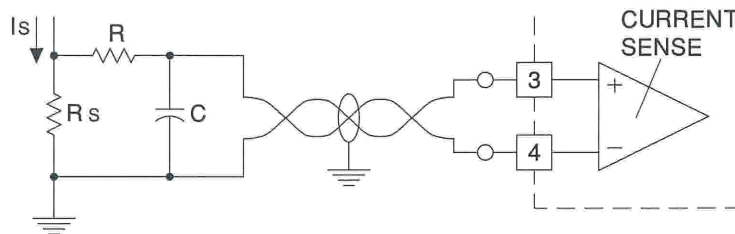

UDG-96185

A small RC filter may be required in some applications to reduce switch transients. Differential input allows remote, noise sensing.

APPLICATIONS INFORMATION (cont.)

UC1856 Open Loop Test Circuit

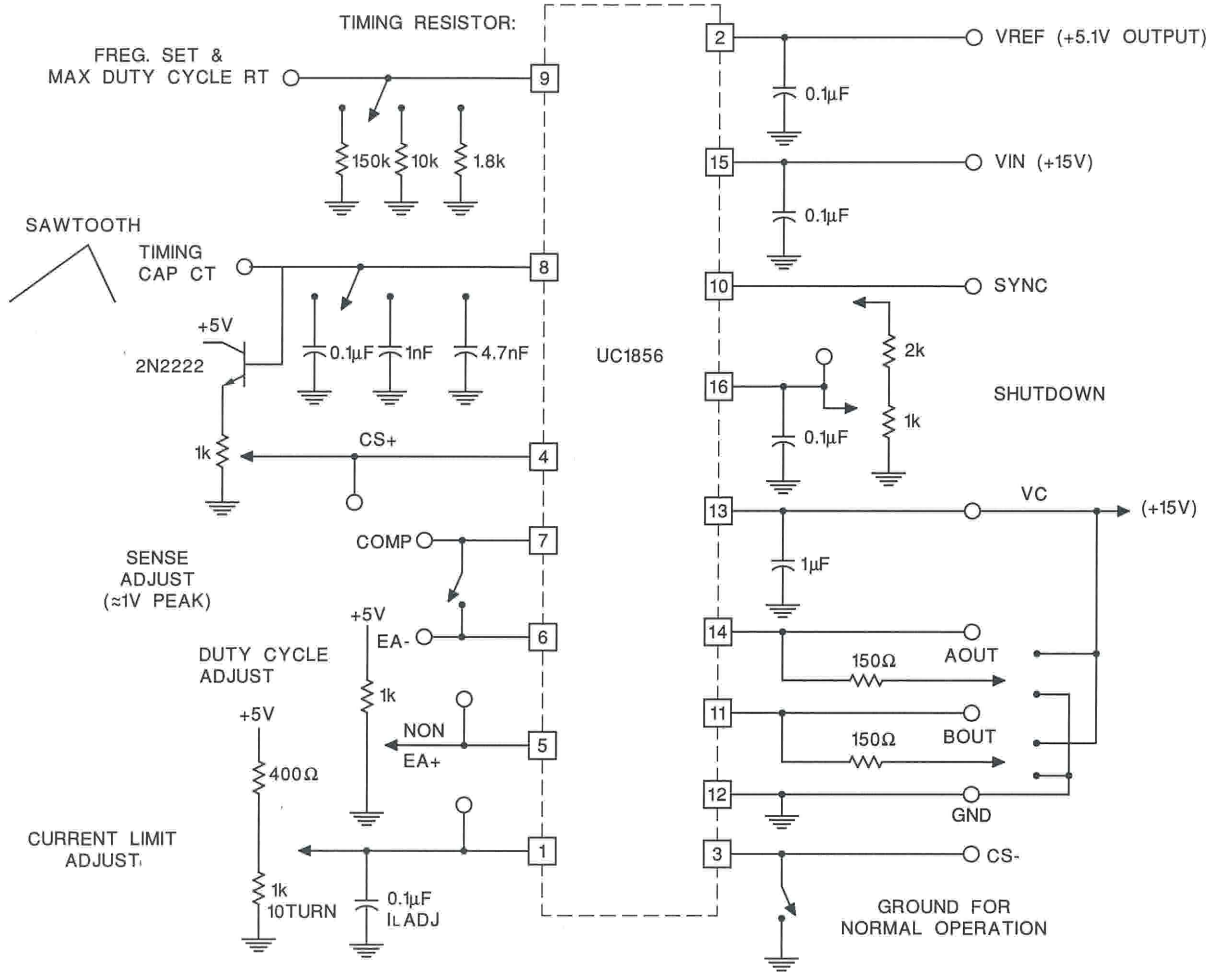

- BYPASS CAPS SHOULD BE LOW ESR & ESL TYPE
- SHORT E/A- & COMP FOR UNITY GAIN TESTING
- THE USE OF A GROUND PLANE IS HIGHLY RECOMMENDED**

UDG-96186

**PACKAGING INFORMATION**

Orderable Device	Status (1)	Package Type	Package Drawing	Pins	Package Qty	Eco Plan (2)	Lead finish/ Ball material (6)	MSL Peak Temp (3)	Op Temp (°C)	Device Marking (4/5)	Samples
5962-9453001M2A	ACTIVE	LCCC	FK	20	55	Non-RoHS & Green	SNPB	N / A for Pkg Type	-55 to 125	5962- 9453001M2A UC1856L20/ 883B	<a href="#">Samples</a>
5962-9453001MEA	ACTIVE	CDIP	J	16	25	Non-RoHS & Green	SNPB	N / A for Pkg Type	-55 to 125	5962-9453001ME A UC1856J/883B	<a href="#">Samples</a>
UC1856J	ACTIVE	CDIP	J	16	25	Non-RoHS & Green	SNPB	N / A for Pkg Type	-55 to 125	UC1856J	<a href="#">Samples</a>
UC1856J883B	ACTIVE	CDIP	J	16	25	Non-RoHS & Green	SNPB	N / A for Pkg Type	-55 to 125	5962-9453001ME A UC1856J/883B	<a href="#">Samples</a>
UC1856L20	ACTIVE	LCCC	FK	20	55	Non-RoHS & Green	SNPB	N / A for Pkg Type	-55 to 125	UC1856L20	<a href="#">Samples</a>
UC1856L20883B	ACTIVE	LCCC	FK	20	55	Non-RoHS & Green	SNPB	N / A for Pkg Type	-55 to 125	5962- 9453001M2A UC1856L20/ 883B	<a href="#">Samples</a>
UC2856DW	OBSOLETE	SOIC	DW	16		TBD	Call TI	Call TI	-40 to 85	UC2856DW	
UC2856DWTR	OBSOLETE	SOIC	DW	16		TBD	Call TI	Call TI	-40 to 85	UC2856DW	
UC2856J	ACTIVE	CDIP	J	16	25	Non-RoHS & Green	SNPB	N / A for Pkg Type	-40 to 85	UC2856J	<a href="#">Samples</a>
UC2856N	ACTIVE	PDIP	N	16	25	RoHS & Green	NIPDAU	N / A for Pkg Type	-40 to 85	UC2856N	<a href="#">Samples</a>
UC3856DW	ACTIVE	SOIC	DW	16	40	RoHS & Green	NIPDAU	Level-2-260C-1 YEAR	0 to 70	UC3856DW	<a href="#">Samples</a>
UC3856DWTR	ACTIVE	SOIC	DW	16	2000	RoHS & Green	NIPDAU	Level-2-260C-1 YEAR	0 to 70	UC3856DW	<a href="#">Samples</a>
UC3856N	ACTIVE	PDIP	N	16	25	RoHS & Green	NIPDAU	N / A for Pkg Type	0 to 70	UC3856N	<a href="#">Samples</a>
UC3856NG4	ACTIVE	PDIP	N	16	25	RoHS & Green	NIPDAU	N / A for Pkg Type	0 to 70	UC3856N	<a href="#">Samples</a>

(1) The marketing status values are defined as follows:

**ACTIVE:** Product device recommended for new designs.

**LIFEBUY:** TI has announced that the device will be discontinued, and a lifetime-buy period is in effect.

**NRND:** Not recommended for new designs. Device is in production to support existing customers, but TI does not recommend using this part in a new design.

**PREVIEW:** Device has been announced but is not in production. Samples may or may not be available.

**OBSOLETE:** TI has discontinued the production of the device.

<sup>(2)</sup> **RoHS:** TI defines "RoHS" to mean semiconductor products that are compliant with the current EU RoHS requirements for all 10 RoHS substances, including the requirement that RoHS substance do not exceed 0.1% by weight in homogeneous materials. Where designed to be soldered at high temperatures, "RoHS" products are suitable for use in specified lead-free processes. TI may reference these types of products as "Pb-Free".

**RoHS Exempt:** TI defines "RoHS Exempt" to mean products that contain lead but are compliant with EU RoHS pursuant to a specific EU RoHS exemption.

**Green:** TI defines "Green" to mean the content of Chlorine (Cl) and Bromine (Br) based flame retardants meet JS709B low halogen requirements of <=1000ppm threshold. Antimony trioxide based flame retardants must also meet the <=1000ppm threshold requirement.

<sup>(3)</sup> **MSL, Peak Temp.** - The Moisture Sensitivity Level rating according to the JEDEC industry standard classifications, and peak solder temperature.

<sup>(4)</sup> There may be additional marking, which relates to the logo, the lot trace code information, or the environmental category on the device.

<sup>(5)</sup> Multiple Device Markings will be inside parentheses. Only one Device Marking contained in parentheses and separated by a "~" will appear on a device. If a line is indented then it is a continuation of the previous line and the two combined represent the entire Device Marking for that device.

<sup>(6)</sup> **Lead finish/Ball material** - Orderable Devices may have multiple material finish options. Finish options are separated by a vertical ruled line. Lead finish/Ball material values may wrap to two lines if the finish value exceeds the maximum column width.

**Important Information and Disclaimer:**The information provided on this page represents TI's knowledge and belief as of the date that it is provided. TI bases its knowledge and belief on information provided by third parties, and makes no representation or warranty as to the accuracy of such information. Efforts are underway to better integrate information from third parties. TI has taken and continues to take reasonable steps to provide representative and accurate information but may not have conducted destructive testing or chemical analysis on incoming materials and chemicals. TI and TI suppliers consider certain information to be proprietary, and thus CAS numbers and other limited information may not be available for release.

In no event shall TI's liability arising out of such information exceed the total purchase price of the TI part(s) at issue in this document sold by TI to Customer on an annual basis.

**OTHER QUALIFIED VERSIONS OF UC1856, UC2856, UC2856M, UC3856 :**

- Catalog : [UC3856](#), [UC2856](#)
- Automotive : [UC2856-Q1](#), [UC2856-Q1](#)
- Military : [UC2856M](#), [UC1856](#)
- Space : [UC1856-SP](#)

NOTE: Qualified Version Definitions:

- Catalog - TI's standard catalog product
- Automotive - Q100 devices qualified for high-reliability automotive applications targeting zero defects
- Military - QML certified for Military and Defense Applications
- Space - Radiation tolerant, ceramic packaging and qualified for use in Space-based application

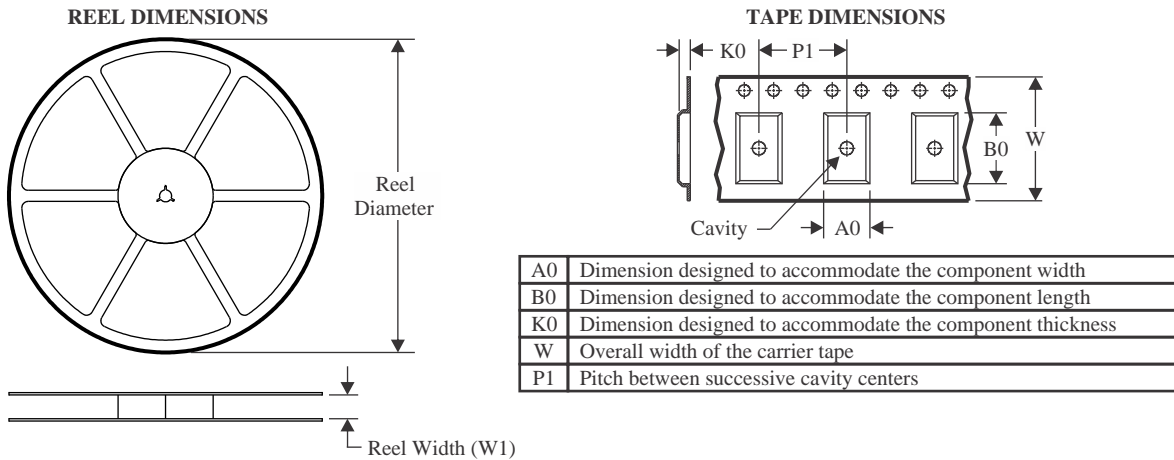
**TAPE AND REEL INFORMATION**

**QUADRANT ASSIGNMENTS FOR PIN 1 ORIENTATION IN TAPE**

\*All dimensions are nominal

Device	Package Type	Package Drawing	Pins	SPQ	Reel Diameter (mm)	Reel Width W1 (mm)	A0 (mm)	B0 (mm)	K0 (mm)	P1 (mm)	W (mm)	Pin1 Quadrant
UC3856DWTR	SOIC	DW	16	2000	330.0	16.4	10.75	10.7	2.7	12.0	16.0	Q1

## TAPE AND REEL BOX DIMENSIONS



\*All dimensions are nominal

Device	Package Type	Package Drawing	Pins	SPQ	Length (mm)	Width (mm)	Height (mm)
UC3856DWTR	SOIC	DW	16	2000	356.0	356.0	35.0

**TUBE**

\*All dimensions are nominal

Device	Package Name	Package Type	Pins	SPQ	L (mm)	W (mm)	T (μm)	B (mm)
5962-9453001M2A	FK	LCCC	20	55	506.98	12.06	2030	NA
UC1856L20	FK	LCCC	20	55	506.98	12.06	2030	NA
UC1856L20883B	FK	LCCC	20	55	506.98	12.06	2030	NA
UC2856N	N	PDIP	16	25	506	13.97	11230	4.32
UC3856DW	DW	SOIC	16	40	507	12.83	5080	6.6
UC3856N	N	PDIP	16	25	506	13.97	11230	4.32
UC3856NG4	N	PDIP	16	25	506	13.97	11230	4.32

## GENERIC PACKAGE VIEW

**DW 16**

**SOIC - 2.65 mm max height**

7.5 x 10.3, 1.27 mm pitch

SMALL OUTLINE INTEGRATED CIRCUIT

This image is a representation of the package family, actual package may vary.  
Refer to the product data sheet for package details.

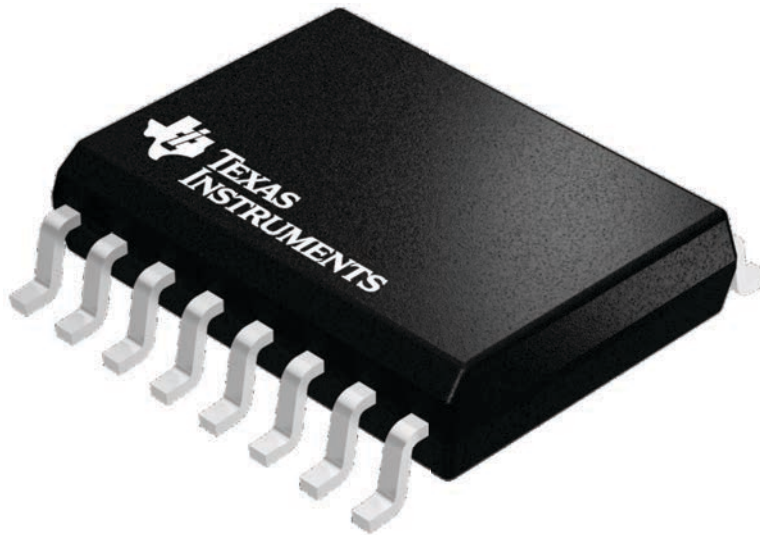

4224780/A



DW0016A

# PACKAGE OUTLINE

SOIC - 2.65 mm max height

SOIC

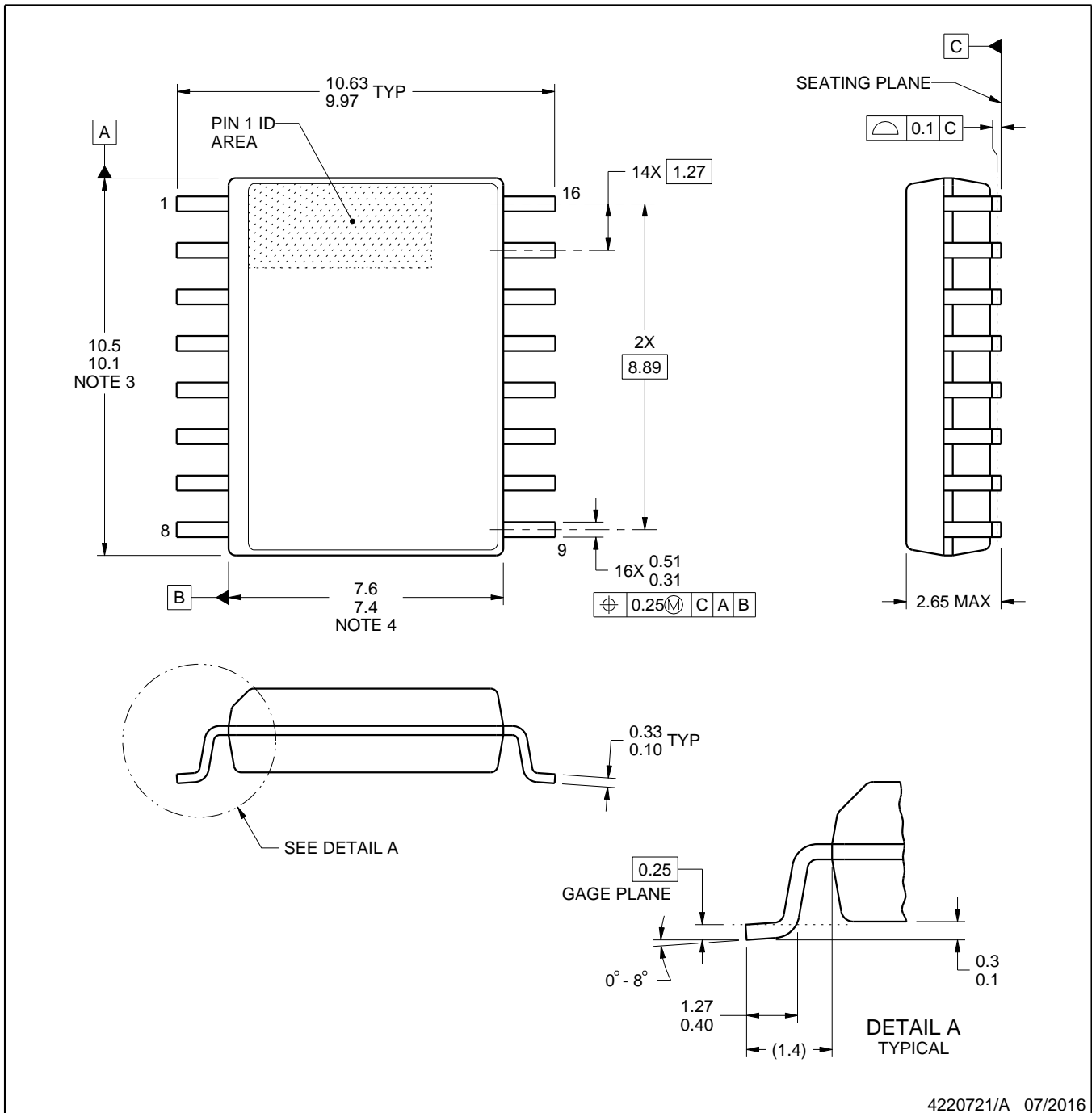

NOTES:

1. All linear dimensions are in millimeters. Dimensions in parenthesis are for reference only. Dimensioning and tolerancing per ASME Y14.5M.
2. This drawing is subject to change without notice.
3. This dimension does not include mold flash, protrusions, or gate burrs. Mold flash, protrusions, or gate burrs shall not exceed 0.15 mm, per side.
4. This dimension does not include interlead flash. Interlead flash shall not exceed 0.25 mm, per side.
5. Reference JEDEC registration MS-013.



# EXAMPLE STENCIL DESIGN

DW0016A

SOIC - 2.65 mm max height

SOIC



SOLDER PASTE EXAMPLE  
BASED ON 0.125 mm THICK STENCIL  
SCALE:7X

4220721/A 07/2016

NOTES: (continued)

8. Laser cutting apertures with trapezoidal walls and rounded corners may offer better paste release. IPC-7525 may have alternate design recommendations.
9. Board assembly site may have different recommendations for stencil design.

## GENERIC PACKAGE VIEW

**FK 20**

**LCCC - 2.03 mm max height**

8.89 x 8.89, 1.27 mm pitch

LEADLESS CERAMIC CHIP CARRIER

This image is a representation of the package family, actual package may vary.  
Refer to the product data sheet for package details.



4229370VA\

J (R-GDIP-T\*\*)

14 LEADS SHOWN

CERAMIC DUAL IN-LINE PACKAGE



DIM \ PINS **	14	16	18	20
A	0.300 (7,62) BSC	0.300 (7,62) BSC	0.300 (7,62) BSC	0.300 (7,62) BSC
B MAX	0.785 (19,94)	.840 (21,34)	0.960 (24,38)	1.060 (26,92)
B MIN	—	—	—	—
C MAX	0.300 (7,62)	0.300 (7,62)	0.310 (7,87)	0.300 (7,62)
C MIN	0.245 (6,22)	0.245 (6,22)	0.220 (5,59)	0.245 (6,22)



4040083/F 03/03

- NOTES:
- All linear dimensions are in inches (millimeters).
  - This drawing is subject to change without notice.
  - This package is hermetically sealed with a ceramic lid using glass frit.
  - Index point is provided on cap for terminal identification only on press ceramic glass frit seal only.
  - Falls within MIL STD 1835 GDIP1-T14, GDIP1-T16, GDIP1-T18 and GDIP1-T20.

N (R-PDIP-T\*\*)

PLASTIC DUAL-IN-LINE PACKAGE

16 PINS SHOWN



- NOTES:
- A. All linear dimensions are in inches (millimeters).
  - B. This drawing is subject to change without notice.
  - Falls within JEDEC MS-001, except 18 and 20 pin minimum body length (Dim A).
  - The 20 pin end lead shoulder width is a vendor option, either half or full width.

## IMPORTANT NOTICE AND DISCLAIMER

TI PROVIDES TECHNICAL AND RELIABILITY DATA (INCLUDING DATA SHEETS), DESIGN RESOURCES (INCLUDING REFERENCE DESIGNS), APPLICATION OR OTHER DESIGN ADVICE, WEB TOOLS, SAFETY INFORMATION, AND OTHER RESOURCES "AS IS" AND WITH ALL FAULTS, AND DISCLAIMS ALL WARRANTIES, EXPRESS AND IMPLIED, INCLUDING WITHOUT LIMITATION ANY IMPLIED WARRANTIES OF MERCHANTABILITY, FITNESS FOR A PARTICULAR PURPOSE OR NON-INFRINGEMENT OF THIRD PARTY INTELLECTUAL PROPERTY RIGHTS.

These resources are intended for skilled developers designing with TI products. You are solely responsible for (1) selecting the appropriate TI products for your application, (2) designing, validating and testing your application, and (3) ensuring your application meets applicable standards, and any other safety, security, regulatory or other requirements.

These resources are subject to change without notice. TI grants you permission to use these resources only for development of an application that uses the TI products described in the resource. Other reproduction and display of these resources is prohibited. No license is granted to any other TI intellectual property right or to any third party intellectual property right. TI disclaims responsibility for, and you will fully indemnify TI and its representatives against, any claims, damages, costs, losses, and liabilities arising out of your use of these resources.

TI's products are provided subject to [TI's Terms of Sale](#) or other applicable terms available either on [ti.com](https://www.ti.com) or provided in conjunction with such TI products. TI's provision of these resources does not expand or otherwise alter TI's applicable warranties or warranty disclaimers for TI products.

TI objects to and rejects any additional or different terms you may have proposed.

Mailing Address: Texas Instruments, Post Office Box 655303, Dallas, Texas 75265

Copyright © 2025, Texas Instruments Incorporated